



# Parts Manual

Mfg. No: 7800217  
2167519B, 21" 6.75 TP Steel Deck Series



---

<b>Model Components</b>	<b>Page</b>
CUTTING DECKS, BLADES.....	4
DECALS.....	6
GRASS BAG COMPONENTS.....	8
HANDLES & CONTROLS.....	10
RECYCLING KITS ACCESSORY.....	14
SIDE CHUTE ADAPTER.....	16
SNAPPERIZER ACCESSORY.....	18
WHEEL BRACKETS, LATCHES (Push).....	20
WHEELS, FRONT & REAR.....	22
Torque Specification Chart.....	24

Not For  
Reproduction

# CUTTING DECKS, BLADES

Note: Unless noted otherwise, use the standard torque specifications

Mfg. No: 7800217

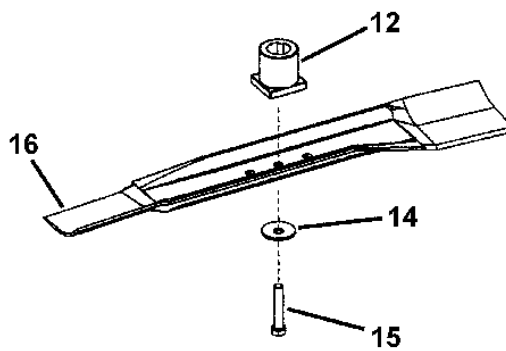
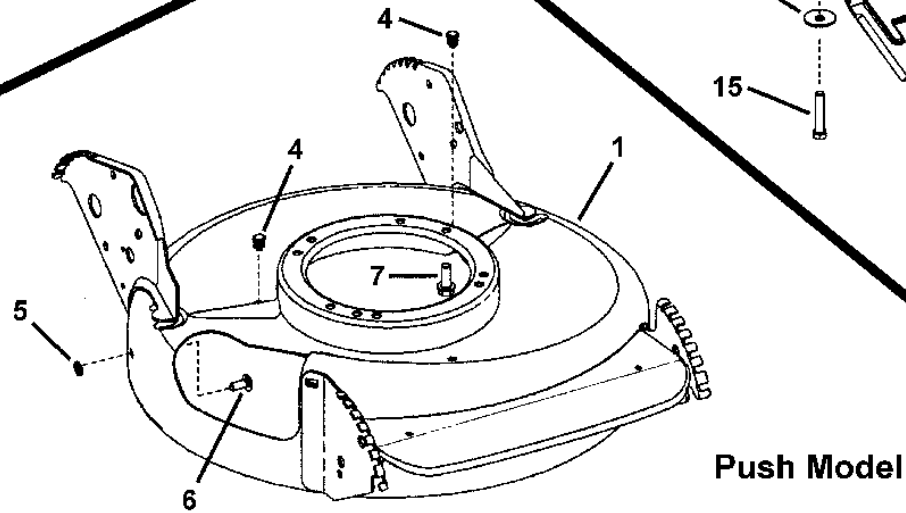
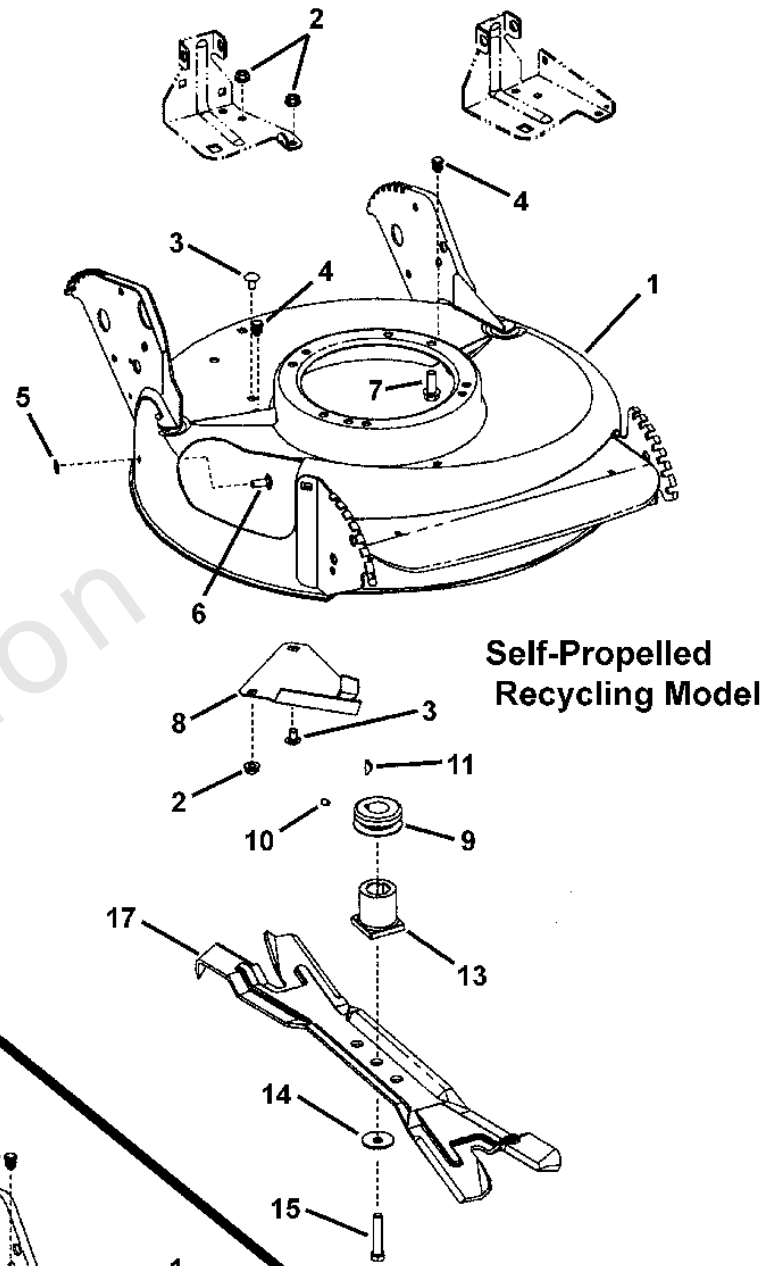
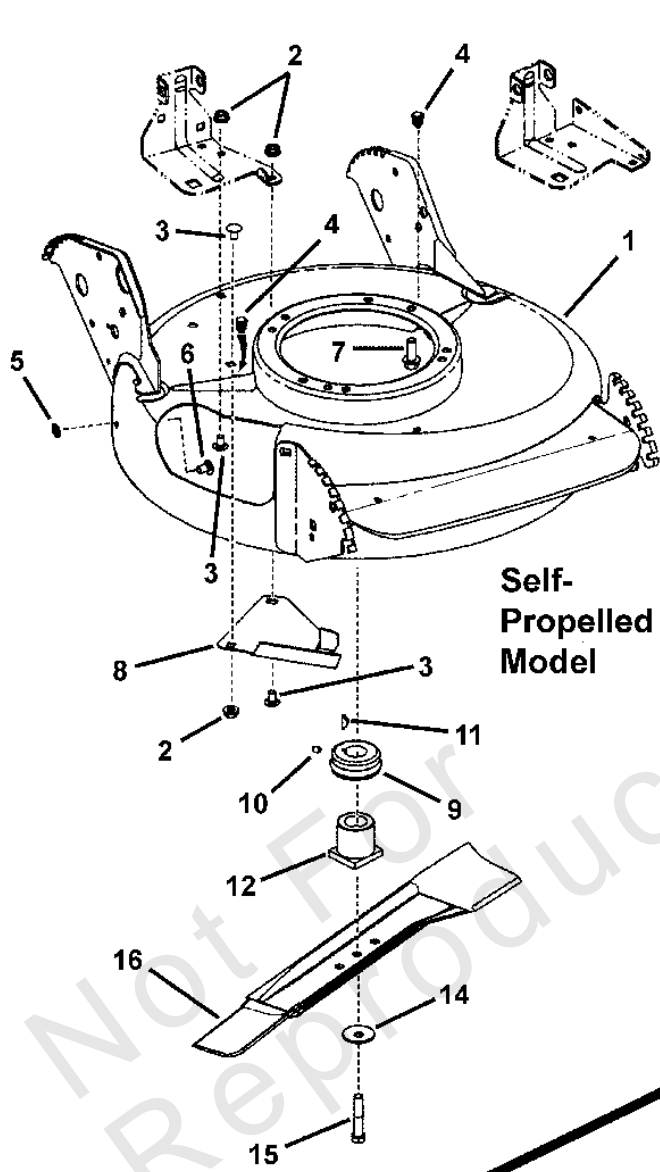

## CUTTING DECKS, BLADES

REF NO	PART NO	QTY	DESCRIPTION
	-----	1	* ENGINE, Kawasaki 6.0 HP, Mod. FJ180V-DS13-R -used on RP216019KWV
	-----	1	* ENGINE, Kawasaki 6 HP Mod. FJ180V-BS23-R -used on P216019KWV
	-----	1	* ENGINE, B&S 675 Series Mod. 126L02-0113-F1 -used on N2167519B & NP2167519B
	-----	1	* ENGINE, B&S 675 Series XRM, B1 Mod. 126T02-0200-B1 -used on 2167519B & P2167519B
	-----	1	* ENGINE, DOV 700 Series Mod. 100602-0121-B1 -used on RP2167519BDV
	-----	1	* ENGINE, B&S 875 Series XIC, F1 Mod. 12S602-0110-F1 -used on NP2187519BV
	-----	1	* ENGINE, B&S 875 Series, Intek 12S502-0112-B1 -used on RP2187519BV & P2187519BV
	-----	1	* ENGINE, B&S 875 Series, Intek, ES, 12S507-0115-B1 -used on RP2187519BVE & P2187519BVE
1	7400026	1	WELDMENT, Deck, 21" Non-Adjust Air -finish: red painted but w/o decals
1	7400027	1	WELDMENT, Deck, 21" S.P., HV, Core Model -finish: red painted but w/o decals
1	7400029	1	WELDMENT, Deck, 21" Push, HV, Core Model -finish: red painted but w/o decals
2	7091070	3	NUT, 5/16-18 Hex Flange Lock, GR 5
3	7090731	3	BOLT, 5/16-18 x 1/2", Short Neck Carriage, GR 5
4	7046780	2	PLUG, Hole, Polyethylene
5	7011791	1	RETAINER, 5/16" Bolt
6	7090001	1	BOLT, 5/16-18 x 3/4" Short Neck Carriage GR 5 -or 7091508
7	7090324	3	SCREW, 3/8-16 x 1" Self-Tapping -engine mount bolts
8	7074568	1	COVER, Belt
9	7015780	1	PULLEY, Engine (25mm I. D. x 2-1/8" O.D.)
10	7090201	1	SET SCREW, 5/16-18 x 5/16" Hex Socket
11	7091214	1	KEY, Woodruff #HP-506 Hi-Pro
12	7015626	1	HUB, Blade Drive, 25 mm I.D.
13	7101414	1	HUB, Blade, 21" WBM, RD, 2 Position
14	7012063	2	WASHER, Cone
15	7090167	1	SCREW, 3/8-24 x 2" Hex Head Cap, GR 5
16	7026691	1	BLADE, 21" Standard Lift
17	7026407	1	BLADE, 21" Ninja (Quad Edge) -Used on Recycling Models

### Footnotes:

NOTE: \* Purchase engine parts from engine manufacturer dealer.

# DECALS

Note: Unless noted otherwise, use the standard torque specifications

Mfg. No: 7800217

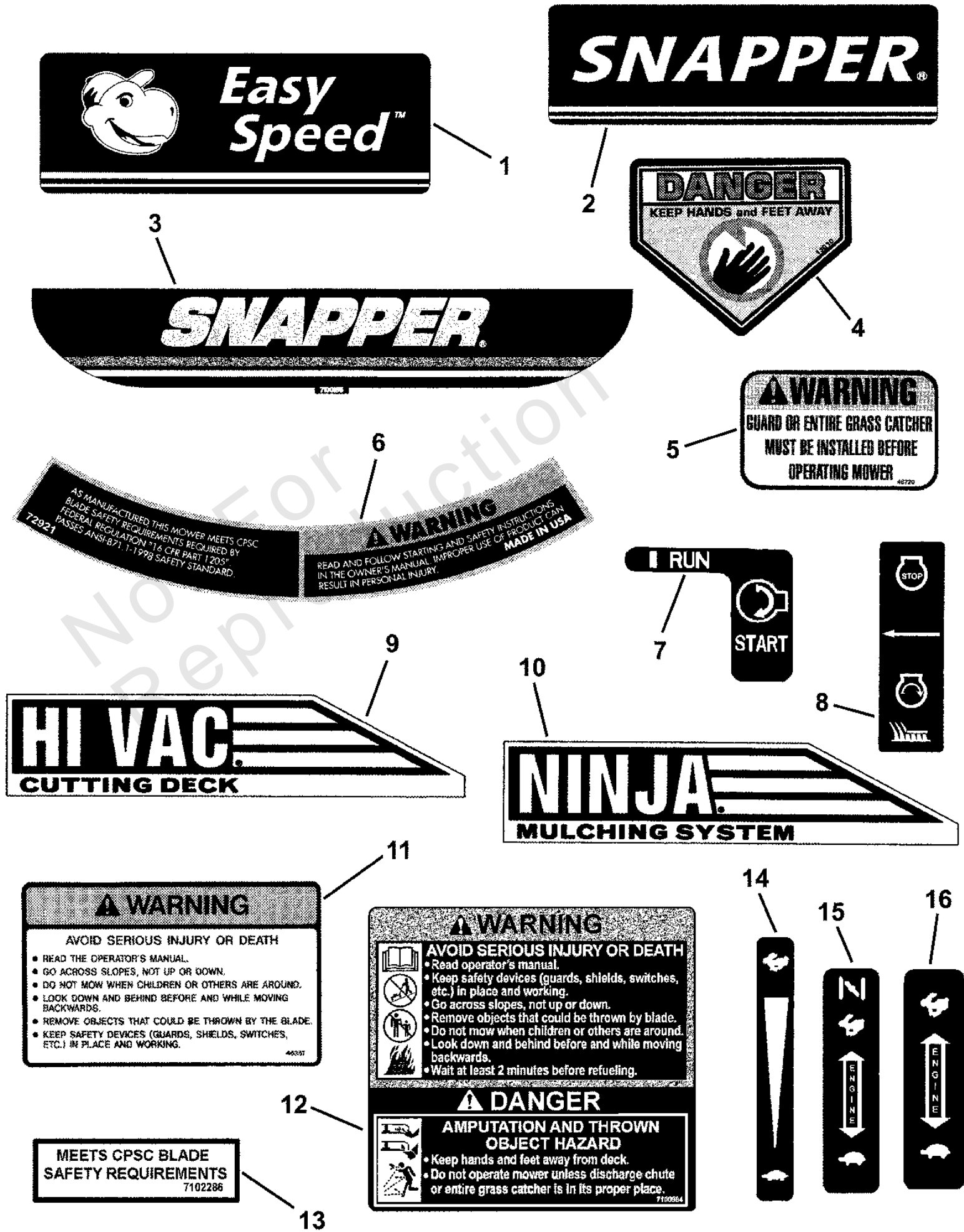

## DECALS

REF NO	PART NO	QTY	DESCRIPTION
1	7100183	1	DECAL, Easy Speed, Control Panel
2	7100182	1	DECAL, Snapper Control Panel
3	7100185	1	DECAL, SNAPPER, Steel Decks
4	7013010	1	DECAL, Danger, Cut Finger
5	7046720	1	DECAL, Chute/Deflector
6	7072921	1	DECAL, Warning (Deck)
7	7075688YP	1	DECAL, Ignition Switch
8	7029782	1	DECAL, OPC Bail (International Symbol)
9	7100398	1	DECAL, Hi Vac Cutting Deck
10	7100410	1	DECAL, NINJA, Mulching System
11	7046357	1	DECAL, Warning
12	7100984	1	DECAL, Warning/Danger Walk-Behind Mowers
13	7102286	1	DECAL, CPSC Blade
14	7075471	1	DECAL, Speed Shift
15	7075524	1	DECAL, Throttle Control, KWV
16	7075532	1	DECAL, Throttle Control, B&S

Not For  
Reproduction

# GRASS BAG COMPONENTS

Note: Unless noted otherwise, use the standard torque specifications

Mfg. No: 7800217

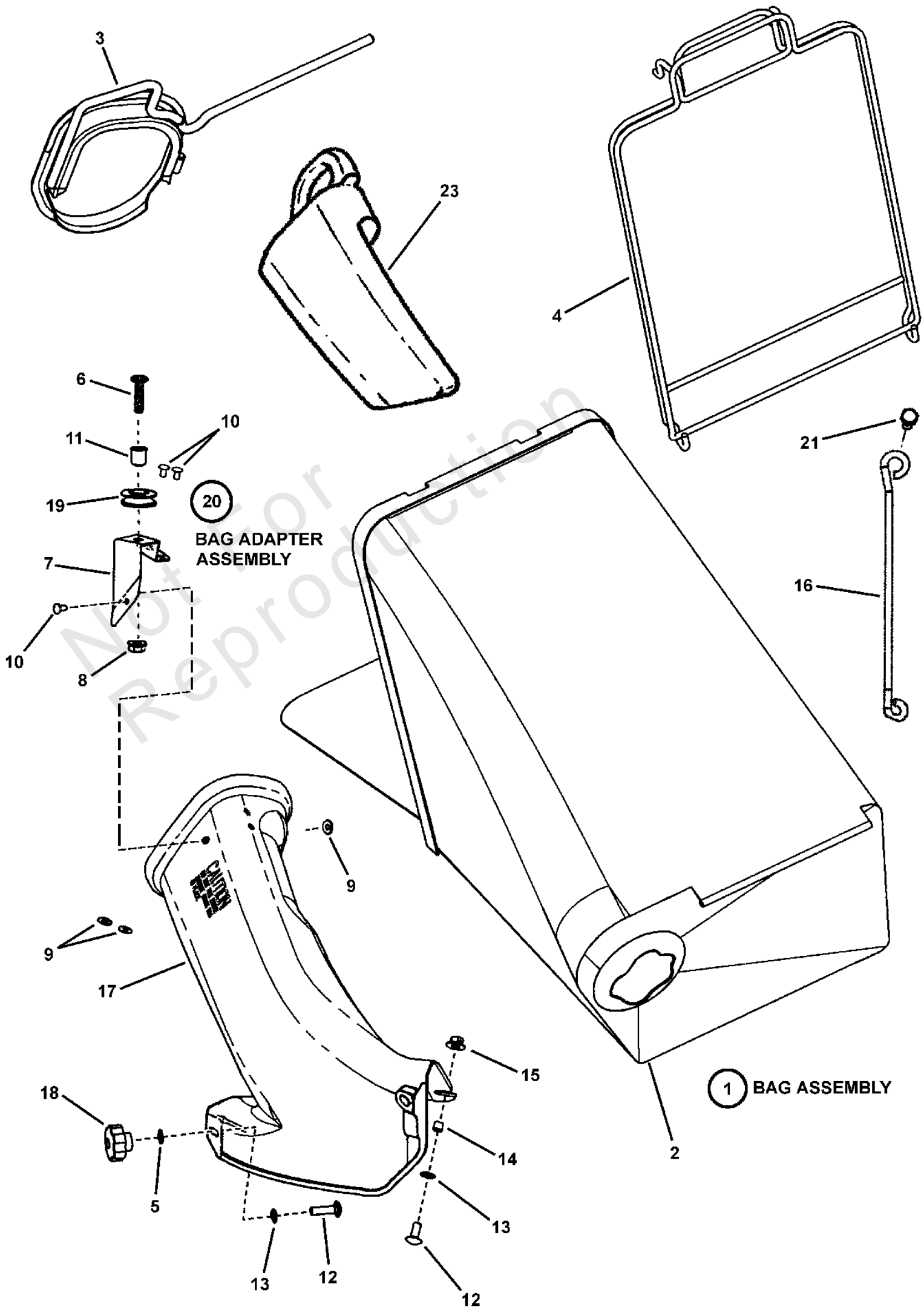



## GRASS BAG COMPONENTS

REF NO	PART NO	QTY	DESCRIPTION
1	7058571	1	BAG ASSEMBLY, (Door) -includes items 2, 3 & 4
2	7075765	1	GRASS BAG, (Door w/Gray Letters)
3	7042489	1	CONNECTOR, Grass Bag (weldment)
4	7051906	1	ASSEMBLY, Bag Wire (12" Wide)
5	7090189	2	WASHER, 5/16" Internal/External Tooth Lock
6	7091984	1	SCREW, 5/16-18 x 1-1/4" Pan Head Machine
7	7047082	1	BRACKET, Rope Guide
8	7090585	2	NUT, 5/16-18 Hex Flange Lock, GR 5 -or 7091601
9	7072107	3	WASHER, 15/32" Flat
10	7013860	3	RIVET, 3/16 x .344
11	7012306	1	BUSHING, Flange, .381 x .625 x .62
12	7090001	3	BOLT, 5/16-18 x 3/4" Short Neck Carriage GR 5 -or 7091508
13	7011791	3	RETAINER, 5/16" Bolt
14	7024340	1	SPACER, .316 I.D. x .375 O.D. x .310 thick
15	7090951	1	NUT, 5/16-18 Hex Large Flange Center Lock
16	7043327	1	BRACE, Bag Adapter -Kawasaki models only
17	7047081	1	ADAPTER, Grass Bag
18	7100516	2	KNOB, Fluted, 5/16-18 x .633
19	7024228	1	PULLEY, Nylon
20	7058037	1	ASSY, Grass Bag Adapter -includes items 6, 7, 8, 9, 10, 11, 17 & 19
21	7078102	1	SCREW, M6 x 1.0 x 30MM Hex Head Cap -Kawasaki models only
22	7078101	1	SLEEVE, .237/.242 ID x .3135/.3185 x .748 (not shown) -Kawasaki models only
23	7016814	1	PLUG, Chute Adapter

# HANDLES & CONTROLS

Note: Unless noted otherwise, use the standard torque specifications

Mfg. No: 7800217

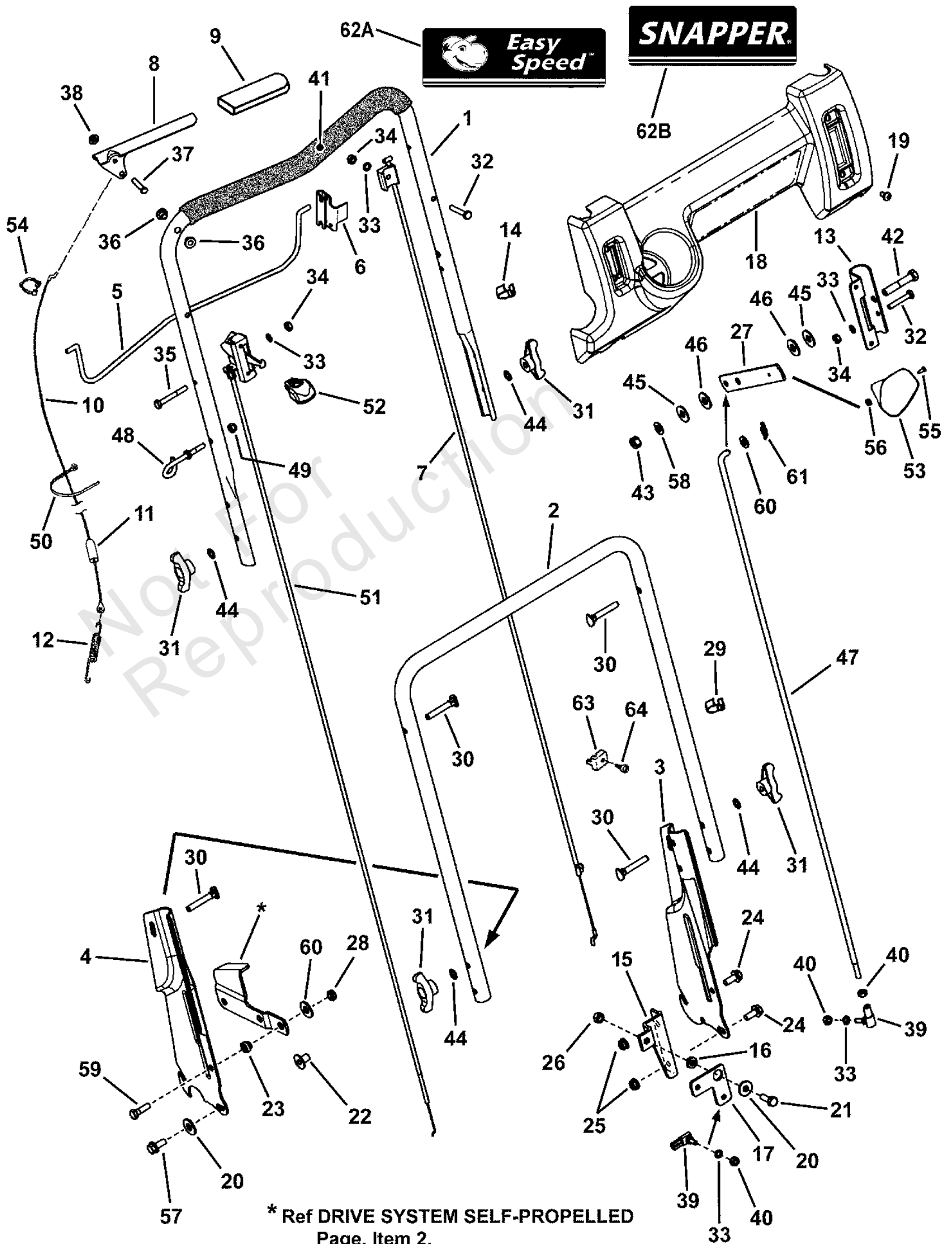

## HANDLES & CONTROLS

REF NO	PART NO	QTY	DESCRIPTION
1	7074411	1	HANDLE, Upper
2	7074156	1	HANDLE, Middle
3	7033985	1	HANDLE, Lower LH (Adjustable)
4	7033986	1	HANDLE, Lower RH (Adjustable)
5	7074418	1	BAIL, OPC Control
6	7034872	1	CLIP, Zone Control
7	7034608	1	* CABLE, Zone Control (52-63/64" Long)
7	7074141	1	* CABLE, Zone Control (56-5/16" Long)
7	7078078	1	* CABLE, Zone Control (50-31/64" Long)
7	7100976	1	* CABLE, Zone Control (53-47/64" Long)
8	7074473	1	HANDLE, Clutch
9	7028407	1	GRIP, International Symbol
10	7034604	1	CABLE, Clutch Control (41-1/4" Long)
11	7012121	1	COVER, Vinyl
12	7012122	1	SPRING, Clutch - 21S
13	7074003	1	BRACKET, Shift
14	7024641	2	TIE, Wire, 1.29 long, black
15	7073822	1	BRACKET, Bell Crank
16	7013849	1	SPACER, .33 x .63 x .156
17	7073913	1	BELL CRANK
18	7074140	1	CONTROL PANEL (w/o Electrical Switch Hole) -Used on Manual Start Models
18	7074469	1	CONTROL PANEL (w/Electrical Switch Hole) -Used on electric start models
18	7073826	1	CONTROL PANEL (w/o wheel drive slot) -used on 2167519BFC & 2167519B
19	7091200	4	SCREW, 1/4-20 x 1/2" Pan Head Self-Tap (Torx)
20	7091130	2	WASHER, .33 x .88 x .09 Flat
21	7091904	1	SCREW, 5/16-18 x 7/8" Hex Head Cap, GR 5
22	7090895	1	TEENUT, 5/16-18 -or 7090538
23	7012114	1	BUSHING, Differential, .328 x .625 x .41
24	7090595	2	BOLT, 5/16-18 x 3/4" Hex Flange Lock GR 5
25	7091070	2	NUT, 5/16-18 Hex Flange Lock, GR 5 -or 7090585 or 7091601
26	7091067	1	NUT, 5/16-18 Hex Center Lock
27	7074113	1	LEVER, Shift
28	7091606	1	NUT, 5/16-24 Hex Center Lock GR 5 -or 7091074
29	7023813	1	CLIP, Wiring Harness
30	7091189	4	SCREW, 5/16-18 x 1-7/8" Curved Head GR 2 -or 7091740
31	7035744	4	KNOB, 5/16-18 Wing (Black)
31	720727	4	KNOB, 5/16-18 Wing (Black) -Briggs part
32	7079577	2	SCREW, 1/4-20 x 1-1/2" Hex Head Cap GR 5
33	7090053	5	WASHER, 1/4" Internal Tooth Lock -or 7091023
34	7091100	3	NUT, 1/4-20 Hex -or 7091576
35	7090505	1	SCREW, 1/4-20 x 2" Hex Head Cap, GR 5

### Footnotes:

NOTE: \* Part number and revision is stamped on cable.

# HANDLES & CONTROLS

Note: Unless noted otherwise, use the standard torque specifications

Mfg. No: 7800217

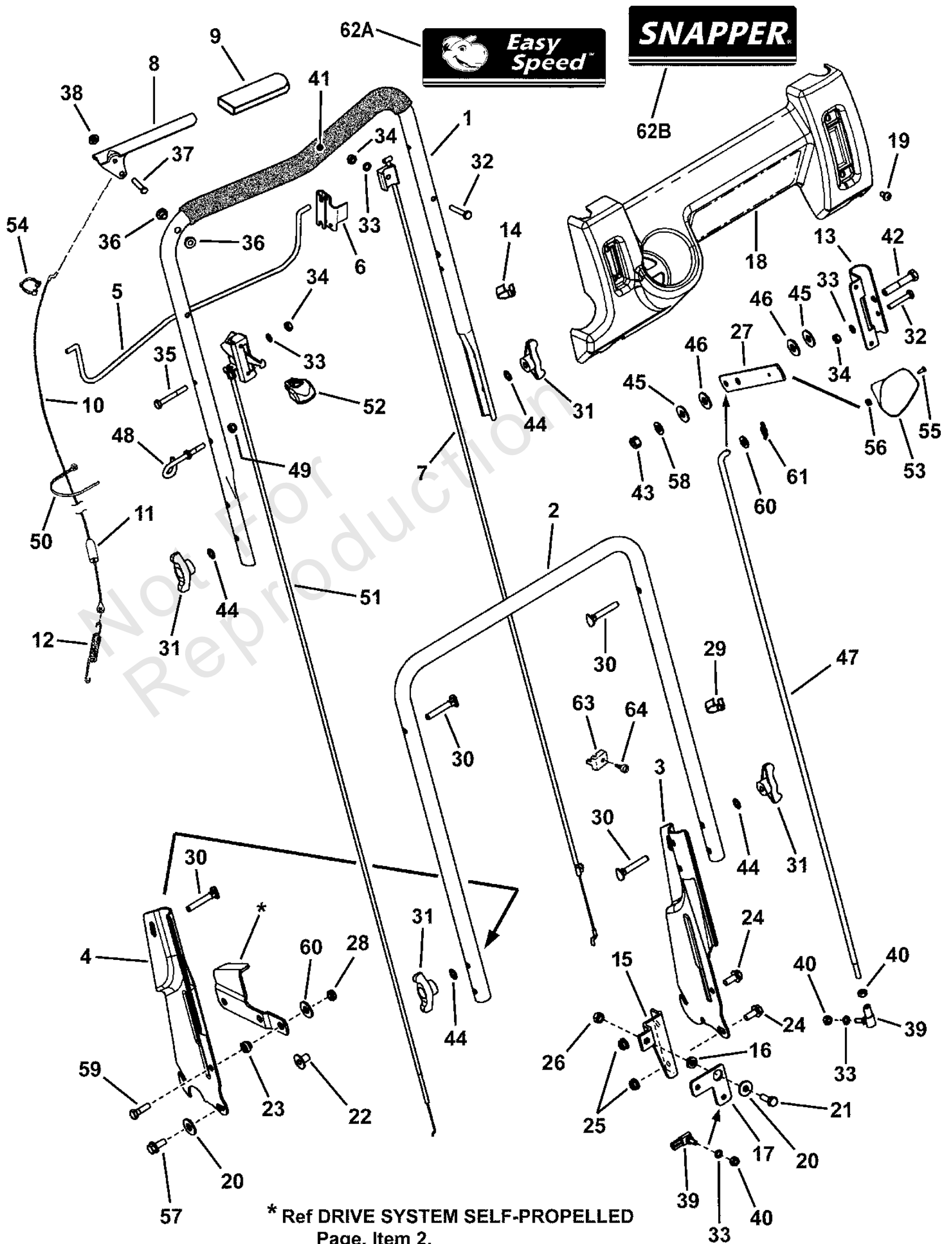

## HANDLES & CONTROLS

REF NO	PART NO	QTY	DESCRIPTION
36	7014343	2	BUSHING, .27 x .35 x .4 Flange
37	7023792	1	PIN, 1/4 x 1-1/2"
38	7091020	1	PUSH-NUT, 1/4"
39	7015753	2	BALL JOINT, 1/4-28
40	7090095	4	NUT, 1/4-28 Hex
41	7023810	1	FOAM GRIP, 18.75" long
42	7091305	1	SCREW, 3/8-16 x 2" Hex Head Cap, GR 5
43	7091585	1	NUT, 3/8-16 Hex Center Lock
44	7090391	4	WASHER, 5/16" Internal Tooth Lock
45	7031961	8	WASHER, 7/16" Flat
46	7028465	2	WASHER, Nylon
47	7074133	1	ROD, Speed Control (1/4-28 thread)
48	7028488	1	GUIDE, Rope (1/4-20 thread)
49	7076978	1	NUT, 1/4-28 Hex GR 5 or B
50	7012080	1	CABLE-TIE, 7"
51	7074460	1	THROTTLE CONTROL, (48.5") -used on Briggs models
51	7074138	1	THROTTLE CONTROL, 6.0 KWV (53.25") -used on Kawasaki models
51	7100975	1	THROTTLE CONTROL, RP, D.O.V. Engine (50.0") -used on Briggs DOV engines
52	7075308	1	THROTTLE KNOB (Red)
53	7075182	1	KNOB, Shift (Red)
54	7026219	1	CLAMP, 7/8" Double Cable
55	7091167	1	SCREW, #8-32 x 1/2" Cross Recess Filister Head Machine
56	7091018	1	NUT, #8-32 Hex
57	7091151	1	SCREW, 5/16-18 x 1-1/4" Hex Washer Head Self-Tap
58	7028568	1	WASHER, Belleville
59	7090238	1	SCREW, 5/16-24 x 1" Hex Head Cap GR 5
60	7090188	1	WASHER, 11/32" Flat
61	7034162	1	COTTER PIN, 5/16 Self Lock
62A	7100183	1	DECAL, Easy Speed, Control Panel
62B	7100182	1	DECAL, Snapper Control Panel -used on Push models
63	7023153	1	CLAMP, Casing
64	7023154	1	SCREW, #10-32 x 5/8" Self-Tap

### Footnotes:

NOTE: \* Part number and revision is stamped on cable.

# RECYCLING KITS ACCESSORY

Note: Unless noted otherwise, use the standard torque specifications

Mfg. No: 7800217

## 7061200 RECYCLING COVER KIT

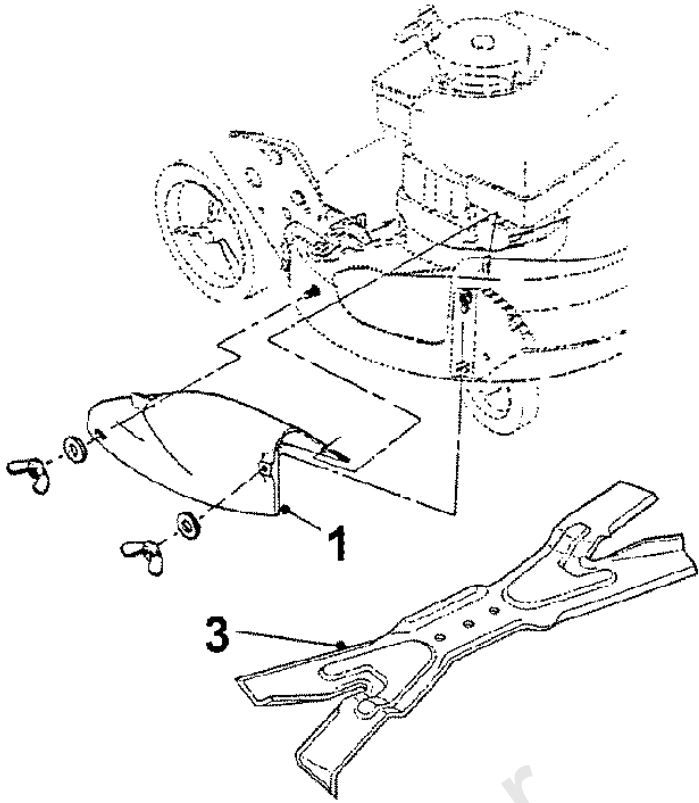

## 7061201 RECYCLING PLUG KIT

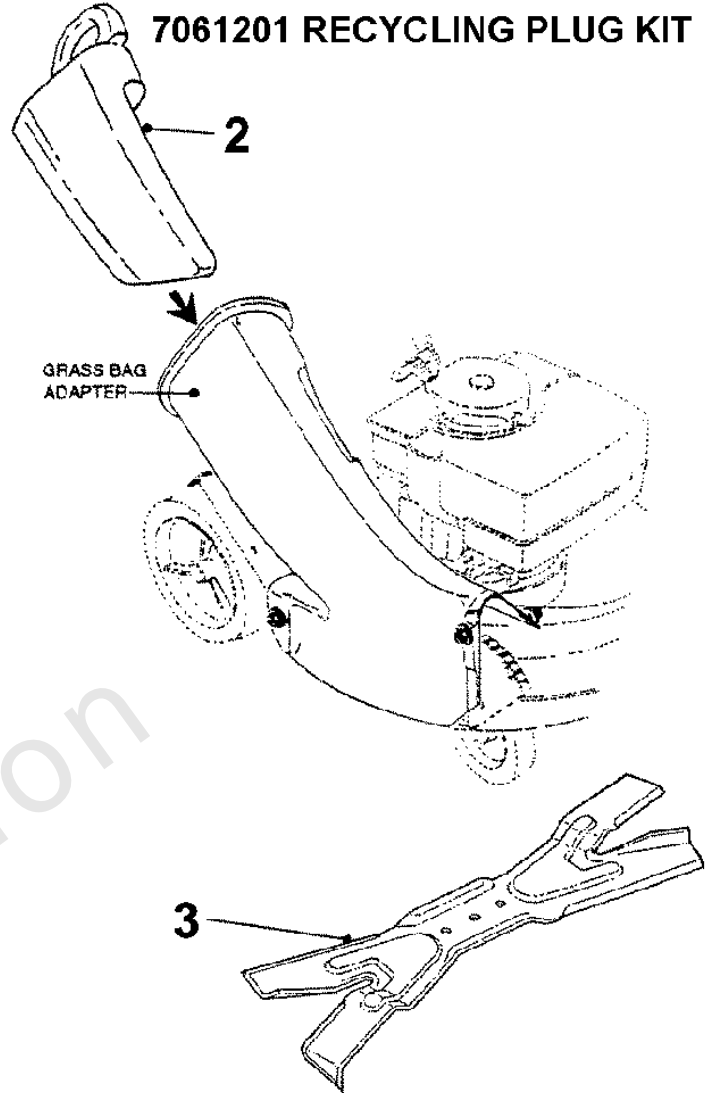

Not For  
Reproduction

## RECYCLING KITS ACCESSORY

REF NO	PART NO	QTY	DESCRIPTION
--	7061200		KIT, Recycling Cover (Includes items 1 & 2 shown below) -for 4HP & above engines
--	7061201		KIT, Recycling Plug (Incl. items 1 & 2 shown below) -for 4HP & above engines
1	7029149	1	COVER, 21" Deck
2	7016814	1	PLUG, Chute Adapter
3	7026407	1	BLADE, 21" Quad Edge Ninja

Not For  
Reproduction

# SIDE CHUTE ADAPTER

Note: Unless noted otherwise, use the standard torque specifications

Mfg. No: 7800217

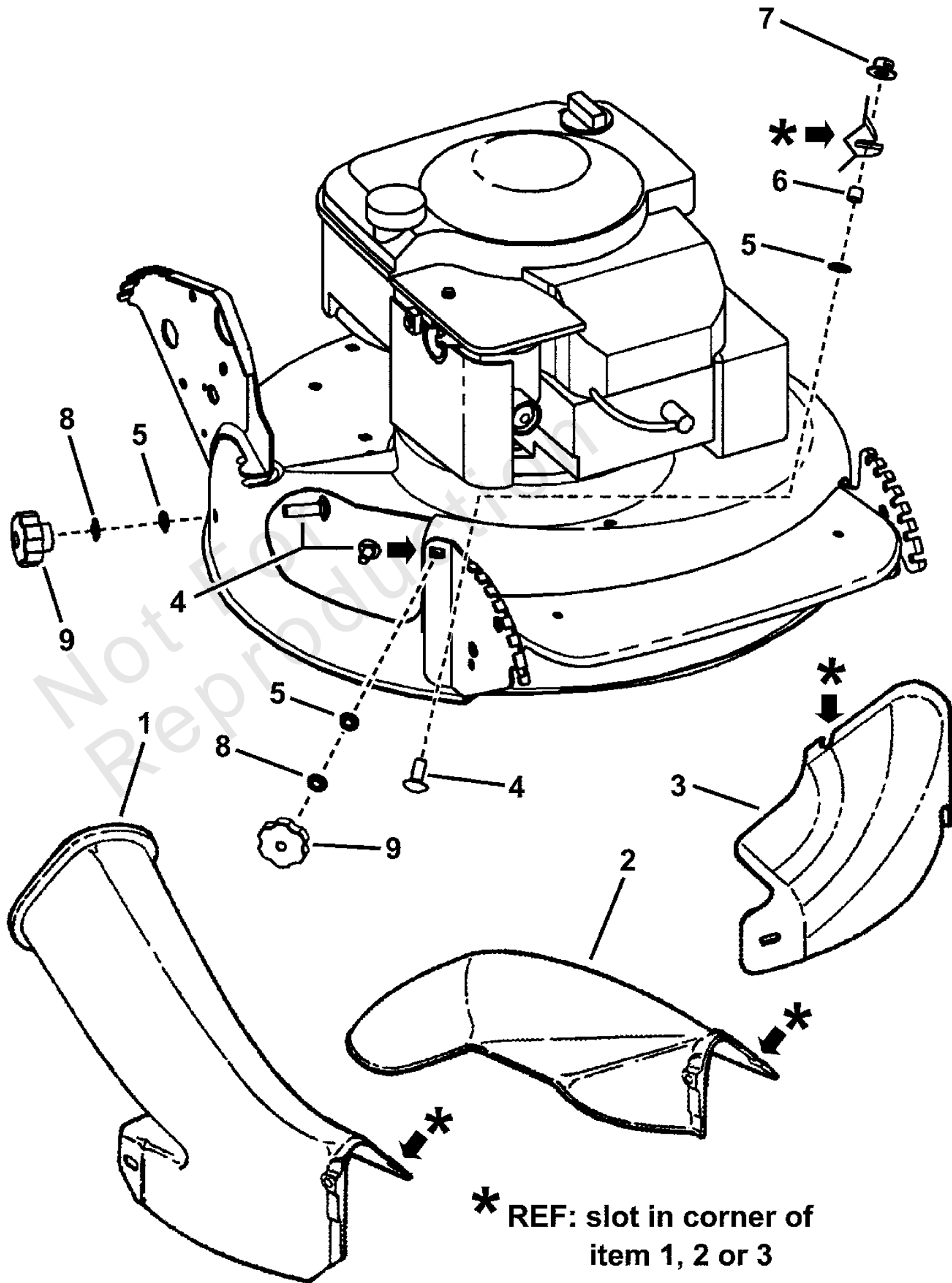



## **SIDE CHUTE ADAPTER**

<b>REF NO</b>	<b>PART NO</b>	<b>QTY</b>	<b>DESCRIPTION</b>
1	7047081	1	ADAPTER, Grass Bag -see Grass Bag Accessory page
2	7042965	1	CHUTE, 21" Side
3	7029149	1	COVER, 21" Deck
4	7090001	3	BOLT, 5/16-18 x 3/4" Short Neck Carriage GR 5
5	7011791	3	RETAINER, 5/16" Bolt
6	7024340	1	SPACER, .316 I.D. x .375 O.D. x .310 thick
7	7090951	1	NUT, 5/16-18 Hex Large Flange Center Lock
8	7090189	2	WASHER, 5/16" Internal/External Tooth Lock
9	7101022	2	KNOB, Fluted, 5/16-18 x 1/2"

Not For  
Reproduction

# SNAPPERIZER ACCESSORY

Note: Unless noted otherwise, use the standard torque specifications

Mfg. No: 7800217

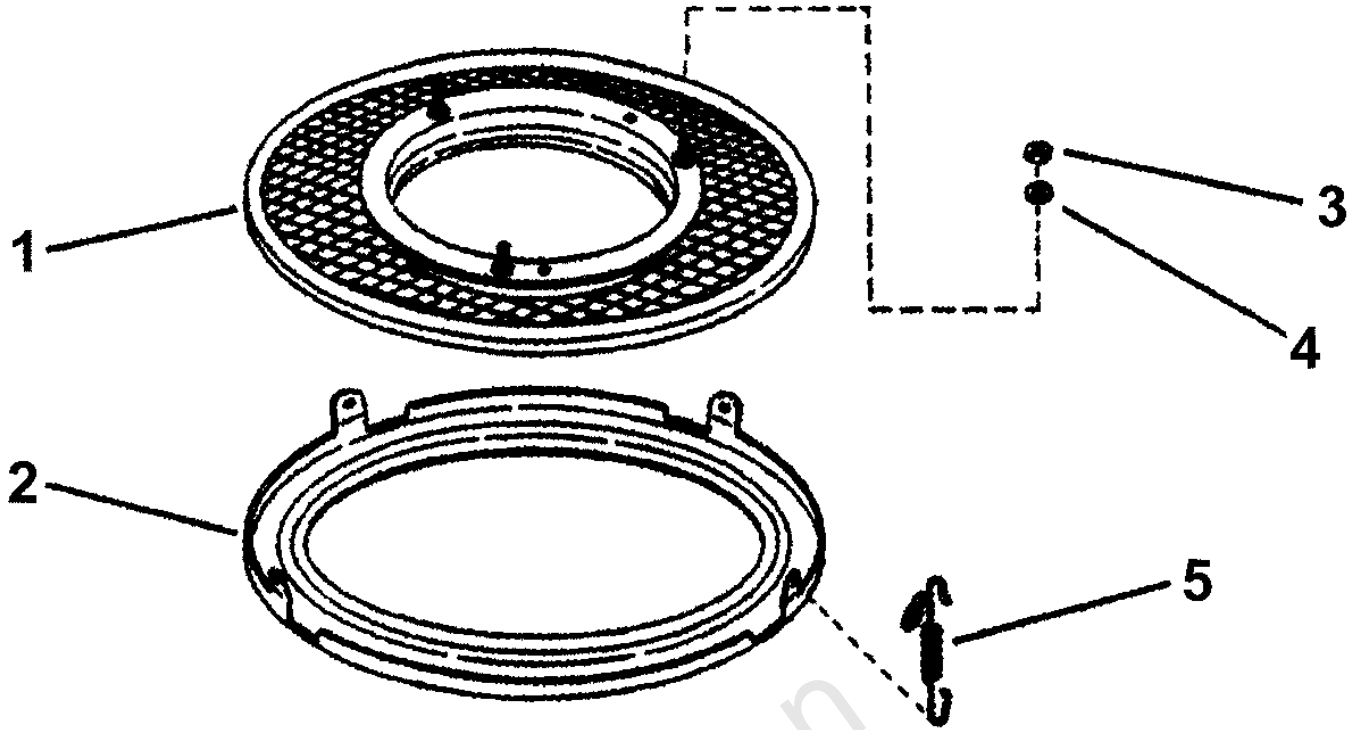

Not For  
Reproduction

## SNAPPERIZER ACCESSORY

---

REF NO	PART NO	QTY	DESCRIPTION
--	7063041		KIT, Snapperizer (Incl. items 1 thru 5) -(for "FR" & "M" type outlip decks)
1	7051243	1	SCREEN, Fastener Assembly
2	7072002	1	RING, Bottom (22.60" Inside Diameter)
3	7091297	3	NUT, 5/16-24 Hex, GR 5
4	7090187	3	WASHER, 5/16" Split Lock
5	7012587	3	SPRING

Not For  
Reproduction

# WHEEL BRACKETS, LATCHES (Push)

Note: Unless noted otherwise, use the standard torque specifications

Mfg. No: 7800217

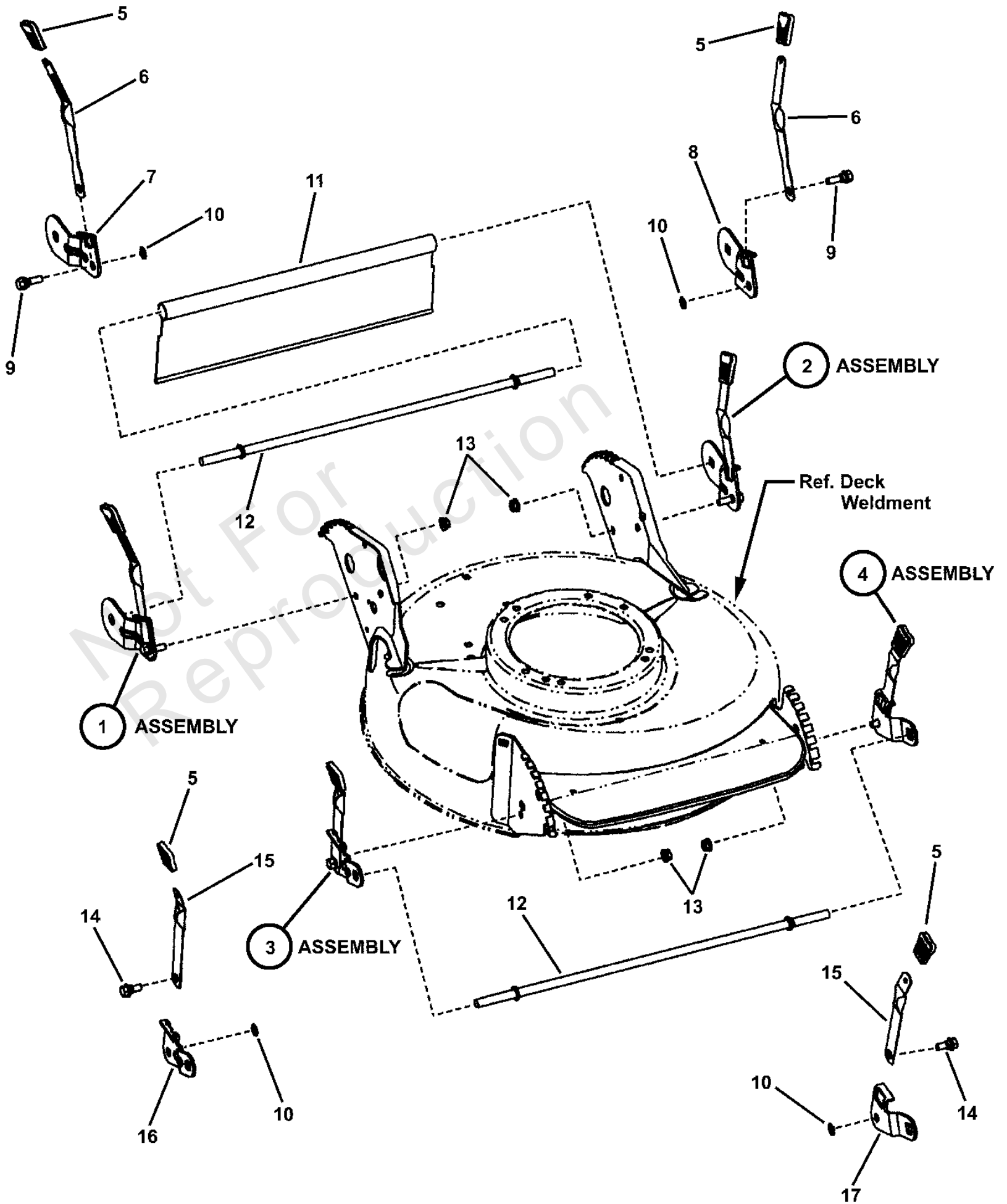

## **WHEEL BRACKETS, LATCHES (Push)**

<b>REF NO</b>	<b>PART NO</b>	<b>QTY</b>	<b>DESCRIPTION</b>
1	7054228	1	ASSY, Wheel Arm, Right Rear (Push)
2	7054229	1	ASSY, Wheel Arm Left Rear Long (Push)
3	7051886	1	ASSEMBLY, Right Wheel Arm
4	7051885	1	ASSEMBLY, Left Wheel Arm
5	7100633	4	GRIP, Height Latch - Black (1.3" Wide)
6	7035717	2	LATCH, Height Adjusting (long)
7	7033776	1	ARM, Wheel, Right Rear
8	7033775	1	ARM, Wheel, Left Rear
9	7011078	2	BOLT, 5/16-18 x 1" Hex Washer Face Shoulder
10	7011791	4	RETAINER, 5/16" Bolt
11	7035741	1	FOOT GUARD, Long Rear (21 Push)
12	7021119	2	AXLE, 21"
13	7091070	4	NUT, 5/16-18 Hex Flange Lock, GR 5 -or 7090585 or 7091601
14	7015761	2	BOLT, 5/16-18 x 3/4" Hex Washer Face Shoulder
15	7012325	2	LATCH, Height
16	7031017	1	WHEEL ARM, R.H. Front (Round Hole)
17	7031016	1	WHEEL ARM, L.H. Front (Square Hole)

Not For  
Reproduction

# WHEELS, FRONT & REAR

Note: Unless noted otherwise, use the standard torque specifications

Mfg. No: 7800217

## FRONT WHEELS

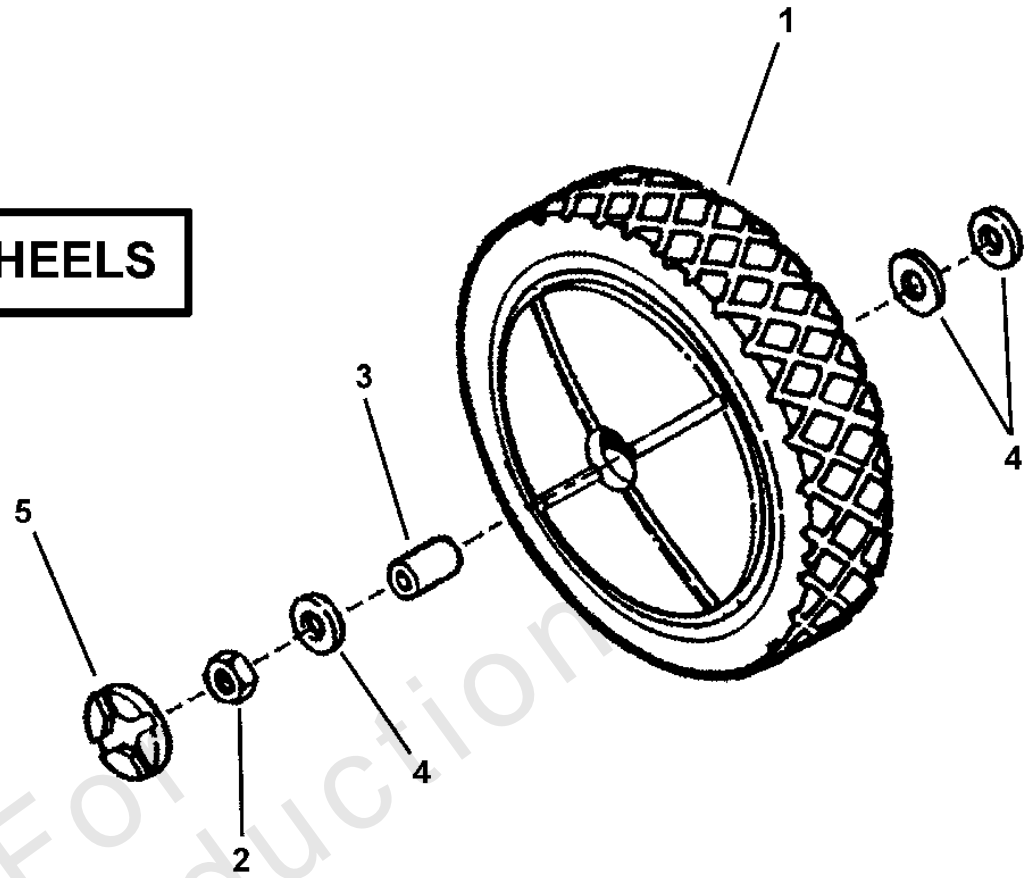

## REAR WHEELS

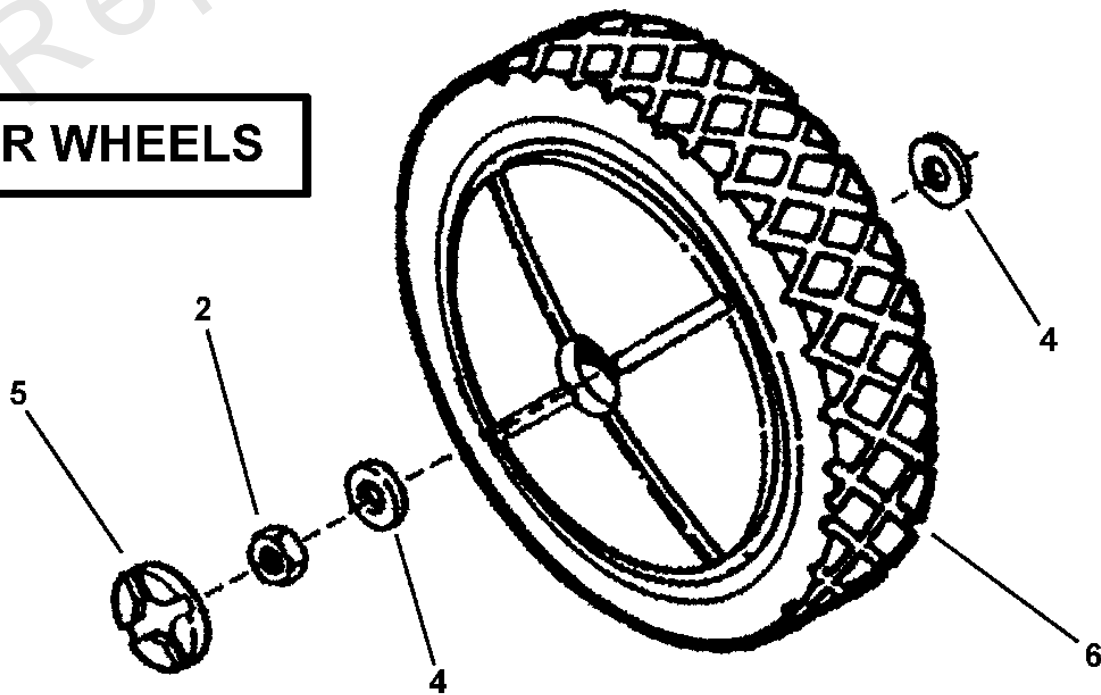

**NOTE: Always replace wheel nut #7090377 when removing or replacing wheel.**

## **WHEELS, FRONT & REAR**

<b>REF NO</b>	<b>PART NO</b>	<b>QTY</b>	<b>DESCRIPTION</b>
1	7029010	2	WHEEL, 8 x 1.75" Plastic
2	7090377	4	NUT, 7/16-20 Hex Center Lock Jam
3	7012309	2	BUSHING, Axle
4	7031961	10	WASHER, 7/16" Flat
5	7017829	4	PLUG, Wheel
6	7074924	2	WHEEL, 10 x 1.75" Plastic (push)
6	7029011	2	WHEEL, 10 x 1.75" Plastic (self-propelled)

Not For  
Reproduction

# Hardware Identification & Torque Specifications

Torque Specification Chart								
FOR STANDARD METRIC MACHINE HARDWARE (Tolerance ± 20%)								
Property Class	5.6		8.8		10.9		12.9	
	Class 5.6		Class 8.8		Class 10.9		Class 12.9	
Size Of Hardware	in/lbs	Nm.	in/lbs	Nm.	in/lbs	Nm.	in/lbs	Nm.
	ft/lbs		ft/lbs		ft/lbs		ft/lbs	
M3	5.88	.56	13.44	1.28	19.2	1.80	22.92	2.15
M4	13.44	1.28	30.72	2.90	43.44	4.10	52.56	4.95
M5	26.4	2.50	60.96	5.75	5.97	8.10	7.15	9.7
M6	44.64	4.3	7.3	9.9	10.3	14	12.1	16.5
M7	5.2	7.1	12.1	16.5	16.9	23	19.9	27
M8	7.7	10.5	17.7	24	25	34	29	40
M10	15	21	35	48	50	67	59	81
M12	26	36	61	83	86.2	117	103	140
M14	42	58	101	132	136	185	162	220
M16	64	88	147	200	210	285	250	340
M18	89	121	202	275	287	390	346	470
M20	126	171	290	390	405	550	486	660
M22	169	230	390	530	559	745	656	890
M24	217	295	497	375	708	960	840	1140
M27	320	435	733	995	1032	1400	1239	1680
M30	435	590	995	1350	1401	1900	1681	2280
M33	590	800	1349	1830	1902	2580	2278	3090
M36	759	1030	1740	2360	2441	3310	2935	3980
M39	988	1340	2249	3050	3163	4290	3798	5150

Torque Specification Chart						
FOR STANDARD MACHINE HARDWARE (Tolerance ± 20%)						
Hardware Grade	No Marks		SAE Grade 5		SAE Grade 8	
	SAE Grade 2		SAE Grade 5		SAE Grade 8	
Size Of Hardware	in/lbs	Nm.	in/lbs	Nm.	in/lbs	Nm.
	ft/lbs		ft/lbs		ft/lbs	
8-32	19	2.1	30	3.4	41	4.6
8-36	20	2.3	31	3.5	43	4.9
10-24	27	3.1	43	4.9	60	6.8
10-32	31	3.5	49	5.5	68	7.7
1/4-20	66	7.6	8	10.9	12	16.3
1/4-28	76	8.6	10	13.6	14	19.0
5/16-18	11	15.0	17	23.1	25	34.0
5/16-24	12	16.3	19	25.8	29	34.0
3/8-16	20	27.2	30	40.8	45	61.2
3/8-24	23	31.3	35	47.6	50	68.0
7/16-14	30	40.8	50	68.0	70	95.2
7/16-20	35	47.6	55	74.8	80	108.8
1/2-13	50	68.0	75	102.0	110	149.6
1/2-20	55	74.8	90	122.4	120	163.2
9/16-12	65	88.4	110	149.6	150	204.0
9/16-18	75	102.0	120	163.2	170	231.2
5/8-11	90	122.4	150	204.0	220	299.2
5/8-18	100	136	180	244.8	240	326.4
3/4-10	160	217.6	260	353.6	386	525.0
3/4-16	180	244.8	300	408.0	420	571.2
7/8-9	140	190.4	400	544.0	600	816.0
7/8-14	155	210.8	440	598.4	660	897.6
1-8	220	299.2	580	788.8	900	1,244.0
1-12	240	326.4	640	870.4	1,000	1,360.0

The guides and ruler furnished below are designed to help you select the appropriate hardware.



Nut, M8

Thread Diameter (mm)

Inside Diameter (in)      Threads per inch

Nut, 1/2-16



Screw, M8- 1.25 x 25

Thread Diameter (mm)      Distance between threads (mm)      Body Length (mm)

Body Diameter      Threads per inch      Body Length (in)

Screw, 1/2- 16 x 2



## Standard Hardware Sizing

When a washer or nut is identified as 1/2" (M8), this is the *Nominal size*, meaning the *inside diameter* is 1/2 inch (8mm metric thread diameter); if a second number is present it represents the *threads per inch* (distance between threads).

When bolt or capscrew is identified as 1/2 - 16 x 2" (M8 - 1.25 x 50), this means the *Nominal size*, or body diameter is 1/2 inch (8mm metric thread diameter), the second number, 16, represents the *threads per inch*, (*distance between threads*). The final number is the body length of the bolt or screw, 2 inches (50mm).

## NOTES

- These torque values are to be used for all hardware excluding: locknuts, self-tapping screws, thread forming screws, sheet metal screws and socket head setscrews.
- Recommended seating torque values for locknuts:
  - for prevailing torque locknuts - use 65% of grade 5 torques.
  - for flange whizlock nuts and screws - use 135% of grade 5 torques.
- Unless otherwise noted on assembly drawings, all torque values must meet this specification.

## Common Hardware Types

Hex Head Capscrew



Washer



Carriage Bolt



Hex Nut

## Wrench & Fastener Size Guide

1/4" Bolt or Nut Wrench—7/16"	5/16" Bolt or Nut Wrench—1/2"	3/8" Bolt or Nut Wrench—9/16"	7/16" Bolt or Nut Wrench (Bolt)—5/8" Wrench (Nut)—11/16"	1/2" Bolt or Nut Wrench—3/4"
M6 Bolt or Nut Wrench—10mm	M8 Bolt or Nut Wrench—13mm	M10 Bolt or Nut Wrench—17mm	M12 Bolt or Nut Wrench—19mm	M14 Bolt or Nut Wrench—22mm



