



Parts Manual

Mfg. No: 7800107
331723BVE, 33" 17 HP Rear Engine
Rider Series 23

Model Components	Page
ACCESSORIES & ATTACHMENTS.....	4
BELTS, BRAKES & INTERLOCK.....	6
BLADE STOP PEDALS.....	8
CUTTING DECKS & DEFLECTOR (28" & 33" Hi-Vac).....	10
DECALS.....	14
DIFFERENTIAL, R. H. FENDER.....	16
ELECTRICAL SYSTEMS (Briggs Magneto Ground).....	18
ELECTRICAL SYSTEMS (For 13.5, 15, 16, 17 & 17.5HP Briggs).....	20
ENGINE, MUFFLER & DRIVE DISC.....	22
FRONT END, STEERING.....	24
FUEL TANK & SEAT.....	26
GEAR SHIFTER ASSEMBLY.....	28
HARDWARE BAGS.....	30
LEFT HAND FENDER & BEARING.....	34
MAIN CASE & L.H. FENDER.....	36
PRIMARY CHAIN CASE & SMOOTH CLUTCH.....	38
RAILS, LIFT ARMS & CAM LIFT.....	40
SPINDLE.....	42
WHEELS, FRONT & REAR.....	44
WIRING SCHEMATIC (13.5, 15, 16, 17 & 17.5HP Briggs Engines).....	46
YOKE LIFT COMPONENTS.....	48
Torque Specification Chart.....	50

Not For
InReproduction

No
Diagram
Available

Parts List
Only

ACCESSORIES & ATTACHMENTS

REF NO	PART NO	QTY	DESCRIPTION
	7060325		KIT, Drive Disc Puller -(used on All RER Aluminum Drive Discs)
	7060697		KIT, Dump Cart
	1692125		KIT, Dump Cart (10 Cu. Ft.)
	7061400		KIT, Gage Wheel (28" & 33")
	7060794		KIT, Gage Wheel (41" & 42")
	7060941		KIT, Single Bag Catcher (25")
	7060942		KIT, Single Bag Catcher (26" & 30")
	7060943		KIT, Single Bag Catcher (28" & 33")
	7060944		KIT, Single Bag Catcher (41" & 42")
	7063281		KIT, Twin Bag Catcher (28" & 33")
	7061414		KIT, Twin Bag Catcher (European 28" & 33")
	7060945		KIT, Twin Bag Catcher (41" & 42")
	7063125		KIT, Clamshell Bagger (28" & 33")
	7060947		KIT, Bag-N-Wagon (28" & 33")
	7060948		KIT, 28" Thatcherizer -(used on All series 7 & Newer Models)
	7060964		KIT, Wagon Cover (28" & 33")
	7072416		KIT, Front Weight -(used on All series 7 & Newer Models)
	7060959		KIT, 36" Dozer Blade
	7060653		KIT, Tire Chains (16 x 6.50-8 Tires)
	7060049		KIT, Tire Chains (16 x 4.50-8 Tires)
	7061823		KIT, Ninja Recycling Cover (25") -(includes 7029143 (25" Ninja blade)
	7061049		KIT, Recycling Cover (25") -(includes 7016967 (25" mulching blade)
	7061253		KIT, Ninja Recycling Cover (28")
	7061254		KIT, Ninja Recycling Cover (30")
	7061255		KIT, Ninja Recycling Cover (33")
	7061987		KIT, Ninja Recycling Cover (41" & 42")
	7061915		KIT, 24" x 36" Tow Behind Poly Lawn Roller

BELTS, BRAKES & INTERLOCK

Note: Unless noted otherwise, use the standard torque specifications

Mfg. No: 7800107

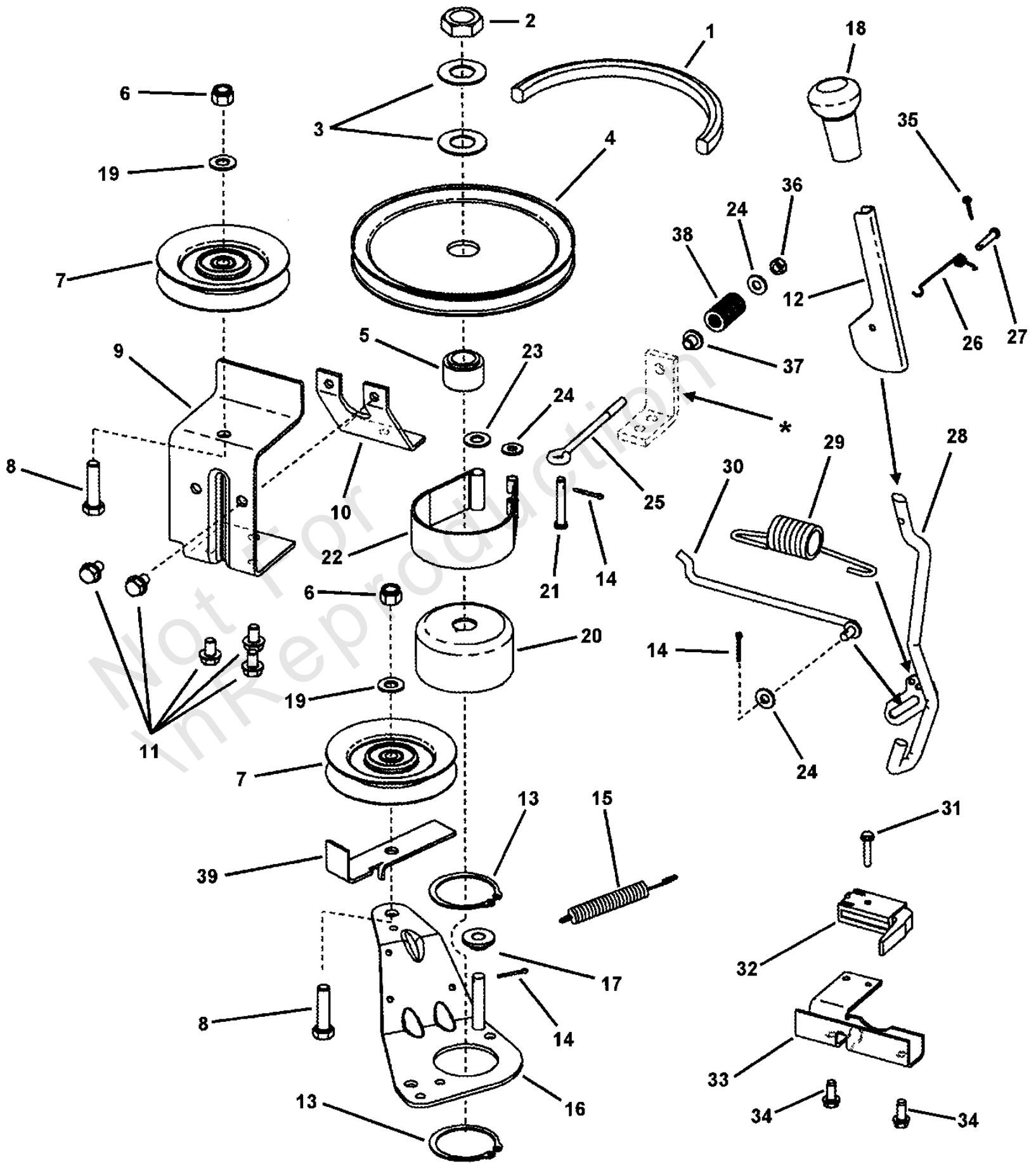

* Ref: RAILS, LIFT ARMS, CAM LIFT page, item # 38

BELTS, BRAKES & INTERLOCK

REF NO	PART NO	QTY	DESCRIPTION
1	7043844	1	* BELT, Drive (73.75" AA Section) -(used on 33" Deck Models)
1	7022252	1	* BELT, Drive (72.75" AA Section) -(used on 25" & 28" Decks)
2	7074467	1	NUT, 3/4-16 Hex Jam, GR 8
3	7032027	2	WASHER, 49/64" I.D. x 1-1/2" O.D. Flat
4	7018781	1	PULLEY, Deck
5	7015290	1	PULLEY, Hub (Powdered Metal)
6	7091299	2	NUT, 3/8-16 Hex Nyloc
7	7029624	2	IDLER PULLEY, 4" Idler
8	7091497	2	SCREW, 3/8-16 x 1-1/2" Hex Head Cap, GR 5
9	7035728	1	BRACKET, Fixed Idler -(used on 33" Deck Models only)
10	7036526	1	BRACE, Fixed Idler Bracket -(used on 33" Deck Models only)
11	7090858	5	SCREW, 5/16-18 x 1/2" Hex Washer Self-Tap
12	7046567BM	1	HANDLE, Blade Engagement (Flip)
13	7010740	2	RING, 2" External Retaining
14	7091597	3	PIN, 3/32 x 3/4" Cotter -(Was 7090037)
15	7036521	1	SPRING, Extension, 4" x 1/2" Diameter
16	7047787	1	WELDMENT, Idler Arm
17	7014314	1	SPACER, .39 x 1.0 x .31 Nylon
18	7046874	1	GRIP, Handle
19	7091514	2	WASHER, 3/8" Flat
20	7035378	1	DRUM, Brake Spindle
21	7014304	1	PIN, 1/4 x 1-5/8" Clevis
22	7034852	1	BAND, Brake (Formed)
23	7090122	2	WASHER, 3/8" Flat SAE
24	7090055	4	WASHER, 1/4" Flat
25	7046677	1	EYE-BOLT, 1/4-20 x 4"
26	7046648	1	SPRING, Torsion, Flip Handle
27	7091974	1	PIN, 3/16 x 1" Clevis
28	7059254	1	WELDMENT, Blade Engagement Handle
29	7014168	1	SPRING, Blade Handle
30	7012055	1	ROD, Idler Control
31	7090299	1	SCREW, #10-32 x 1" Hex Washer Head Self-Tap
32	7018524	1	SWITCH, Deck Interlock (NO)
33	7038021	1	MOUNT, Handle/Switch
34	7091819	2	SCREW, 1/4-20 x 5/8" Hex Washer Head Self-Tap -(Was 7090362)
35	7090555	1	PIN, 3/32 x 1/2" Cotter
36	7091705	1	NUT, 1/4-20 Hex Top Lock -(Was 7090761)
37	7014343	1	BUSHING, Flange .27 x .35 x .4
38	7046782	1	SPRING, Rectangular Wire Die, Blue
39	7032111	1	RESTRICTOR, Belt

Footnotes:

Note: * Belt part numbers are printed on belts.

BLADE STOP PEDALS

Note: Unless noted otherwise, use the standard torque specifications

Mfg. No: 7800107

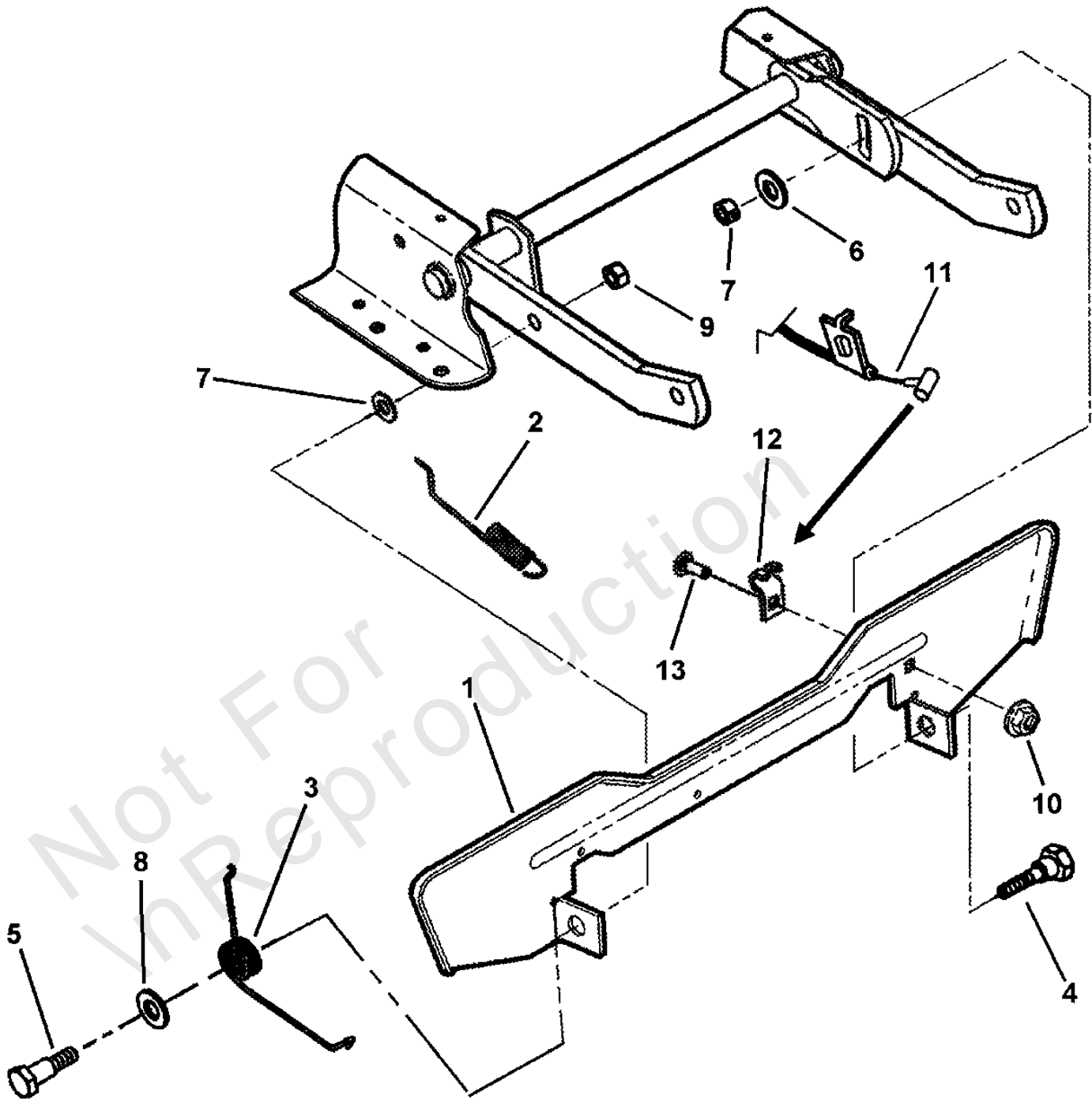

BLADE STOP PEDALS

REF NO	PART NO	QTY	DESCRIPTION
1	7073267	1	FOOT PEDAL, Blade Stop Control
2	7074649	1	SPRING, Latching (.072 dia.) -(replaces 7035669 (.062 dia.))
3	7015448	1	SPRING, Pedal
4	7015495	1	SHOULDER BOLT, 3/8-24 w/Nylon Patch, GR 5
5	7015446	1	SHOULDER BOLT, 3/8-24 x 9/16"
6	7032030	1	WASHER, Flat 13/32" ID x 1.25" x 1/8" Thick ZP -(Was 7012063)
7	7091630	1	NUT, 3/8-24 Hex, GR B -(Was 7090155)
8	7091587	2	WASHER, 1/2" Flat SAE -(Was 7090250)
9	7090289	1	NUT, 3/8-24 Hex Center Lock
10	7091584	1	NUT, 1/4-20 Hex Flange Lock, GR 5
11	7073216	1	CABLE ASSEMBLY, No Reverse in Mow
12	7073217	1	CLIP, Cable
13	7091530	1	BOLT, 1/4-20 x 3/4" Square Neck Carriage, GR 5 -(Was 7091776)

CUTTING DECKS & DEFLECTOR (28" & 33" Hi-Vac)

Note: Unless noted otherwise, use the standard torque specifications

Mfg. No: 7800107

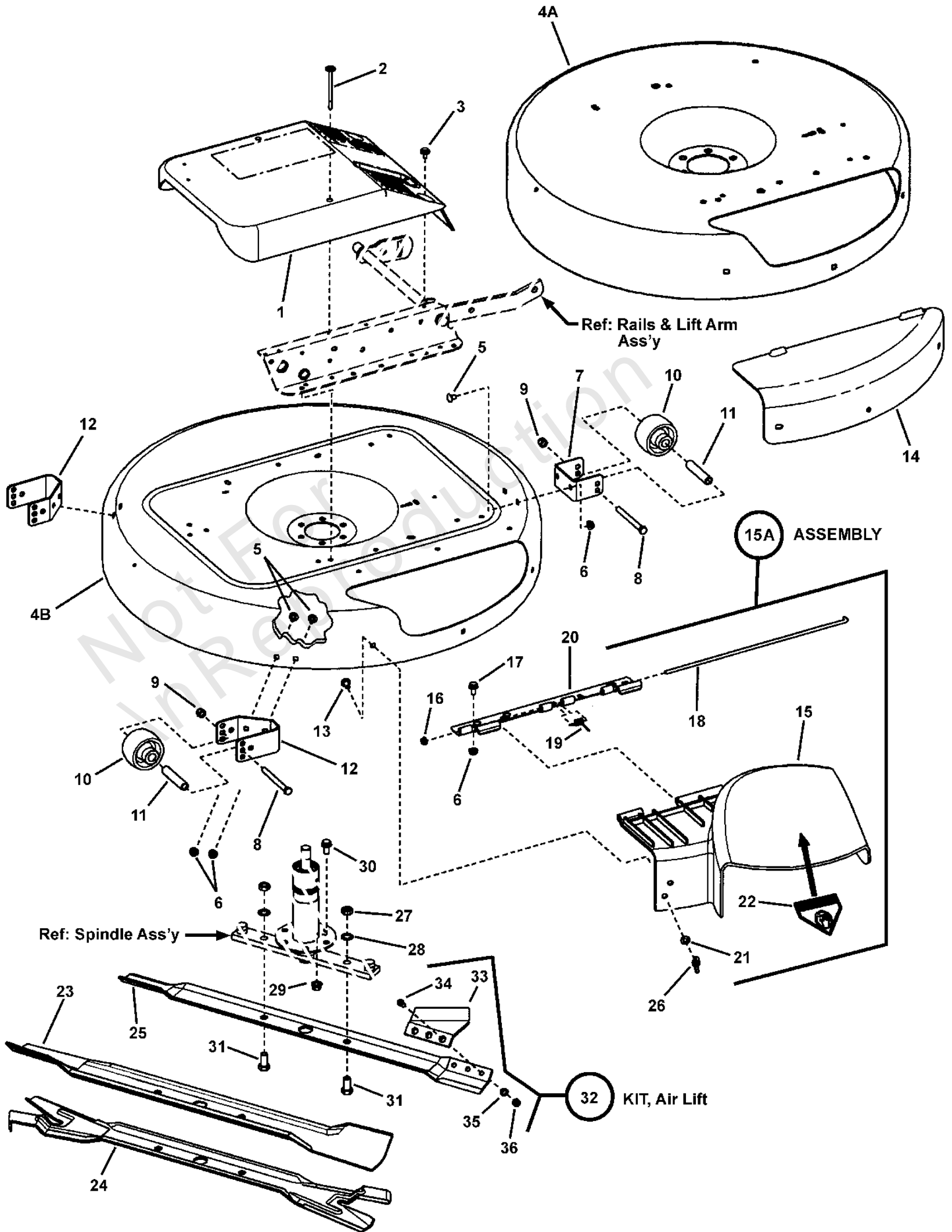

CUTTING DECKS & DEFLECTOR (28" & 33" Hi-Vac)

REF NO	PART NO	QTY	DESCRIPTION
1	7073434	1	COVER, Spindle
2	7091015	2	SCREW, 1/4-20 x 3-1/2" Hex Head w/Free Spinning Washer
3	7091016	4	SCREW, 1/4-20 x 5/8" Hex Head w/Free Spinning Washer
4A	7061970	1	DECK, 28" Replacement -(Painted deck w/decals & wheel bracket fasteners)
4B	7061972	1	DECK, 33" Replacement -(Painted deck with decals)
5	7090731	6	BOLT, 5/16-18 x 1/2" Short Neck Carriage, GR 5
6	7091601	8	NUT, 5/16-18 Hex Flange Lock, GR 5 -(Was 7091070)
7	7033570D	1	BRACKET, Gage Wheel (Front)
8	7091532	3	SCREW, 3/8-24 x 3-3/4" Hex Head Cap, GR 5
9	7091518	3	NUT, 3/8-24 Hex Nyloc
10	7019190	3	WHEEL, Gage
11	7015272	3	SPACER
12	7033571D	2	BRACKET, Gage Wheel (Rear)
13	7091508	2	BOLT, 5/16-18 x 3/4" Short Neck Carriage, GR 5 -(or 7090001)
14	7016983	1	COVER, 28" Mulcher
14	7016984	1	COVER, 33" Mulcher
15	7026233	1	DEFLECTOR, Discharge, 28" & 33"
15A	7500484	1	ASSEMBLY, Discharge Deflector, 28" & 33" (without decal) -(Incl. items 15, 16, 18, 19, & 20)
16	7026483	2	PUSH NUT, 1/4"
17	7091811	3	BOLT, 5/16-18 x 5/8" Hex Flange Lock, GR 5 -(or 7091811)
18	7026234	1	PIN, Hinge
19	7016341	1	SPRING, Hinge
20	7300886BM	1	HINGE, Deflector (Deck side) -(Was 7033780)
21	7091296	2	WASHER, 5/16" Flat
22	7013010	1	DECAL, Danger, (Cut Finger) -(or 7026831)
23	7104196BM	1	BLADE, 28" Hat Shaped Hi-Lift -(standard equipment (Was 7035635)
23	7034168	1	BLADE, 33" Hat Shaped Hi-Lift -(standard equipment)
24	7026453	1	BLADE, Ninja, 28" -(or 7104083BM)
24	7024741	1	BLADE, Ninja, 33"
25	7019515	1	BLADE, 28"
25	7019523	1	BLADE, 33"
26	7091537	2	NUT, 5/16-18 Wing -(Was 7090492)
27	7091939	2	NUT, 1/2-20 Hex, GR 5 or B -(Was 7090559, Hex Jam Nut)
28	7090509	2	WASHER, 1/2" Internal Tooth Lock
29	7091619	9	NUT, 3/8-16 Hex Flange Lock -(Was 7090613)
30	7091588	3	BOLT, 3/8-16 x 3/4" Hex Flange Lock -(Was 7090612)
31	7090491	2	SCREW, 1/2-20 x 1-1/4" Hex Head Cap, GR 5 -(Was 7090392)
32	7060480	1	KIT, Air Lift, Hi-Vac (Includes items 33, 34, 35 & 36) -(used on 28" & 33" Decks)
33	7037723	2	AIR LIFT, Hi-Vac (3 hole)

CUTTING DECKS & DEFLECTOR (28" & 33" Hi-Vac)

Note: Unless noted otherwise, use the standard torque specifications

Mfg. No: 7800107

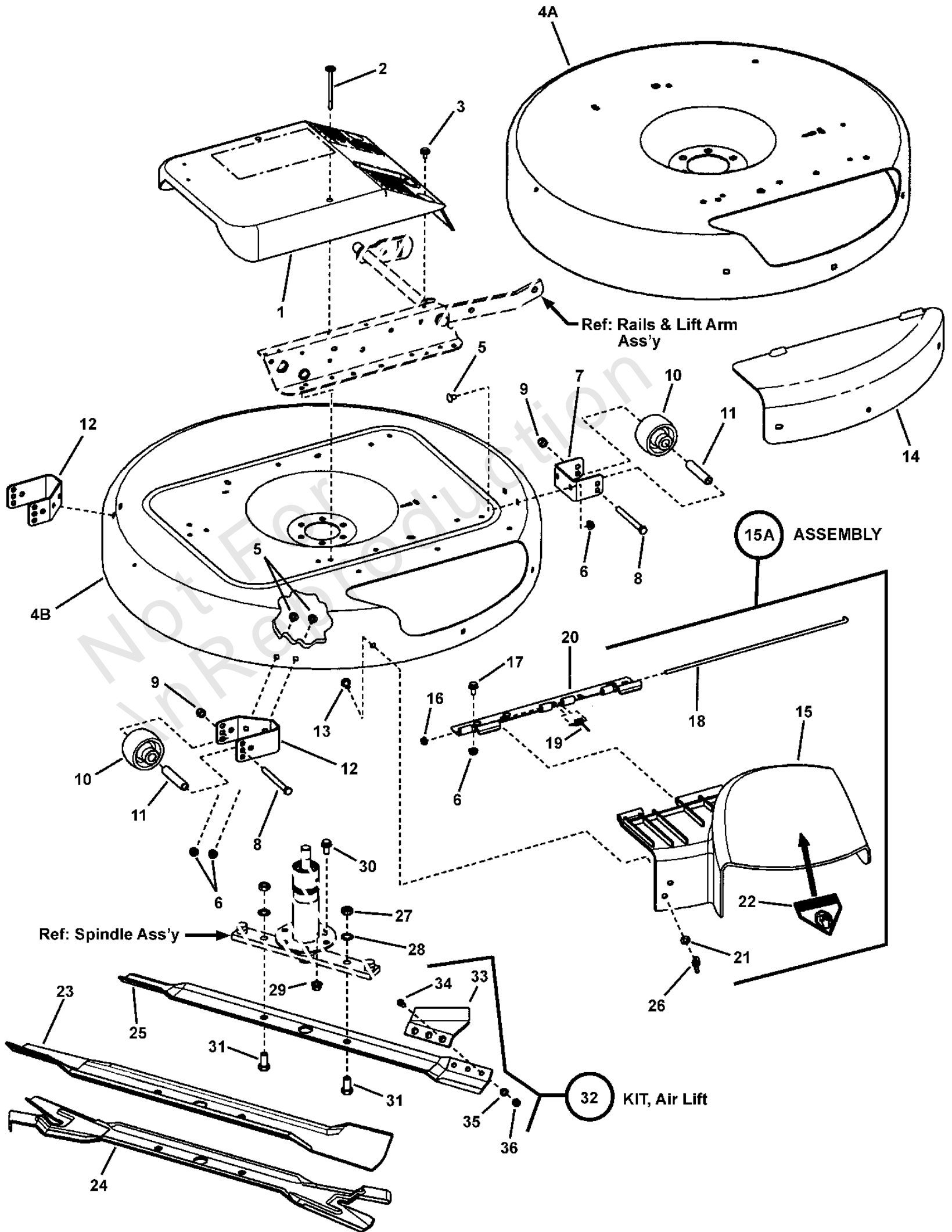

CUTTING DECKS & DEFLECTOR (28" & 33" Hi-Vac)

REF NO	PART NO	QTY	DESCRIPTION
34	7090228	6	SCREW, 5/16-24 x 11/16" Oval Head Machine
35	7090391	6	WASHER, 5/16" Internal Tooth Lock
36	7090223	6	NUT, 5/16-24 Hex

Not For In Reproduction

1 **DANGER**
 • BLADES MUST BE TURNED OFF BEFORE BACKING MACHINE
 • DO NOT ALLOW CHILDREN ON MACHINE (EVEN WITH BLADES OFF) OR IN YARD WHEN MOWING

2 **OHV**

3 **ELECTRIC START**
SNAPPER
 BACK-UP RECOIL

4 **1**
2
3
4
5

5 **DANGER**
 KEEP HANDS and FEET AWAY

6 **WARNING**
 GUARD OR ENTIRE GRASS CATCHER MUST BE INSTALLED BEFORE OPERATING MOWER

7 **28 INCH**
 PATENTED HI-VAC

8 **33 INCH**
 PATENTED HI-VAC

9 **CAUTION**
 POSITIVE (+) BATTERY POST MUST BE TO REAR TO PREVENT ARCING AND POSSIBLE EXPLOSION OR FIRE.
 USE ONLY SNAPPER REPLACEMENT BATTERY TO AVOID ACID DAMAGE.

10 REMOVE BATTERY BEFORE STANDING MOWER ON END FOR MORE THAN 2 HOURS

11 TO STAND ON END: CLOSE CAP VENT AND REMOVE TANK IF FUEL IS OVER 3/4 FULL.

12 **BEFORE STARTING ENGINE OR DISMOUNTING MOWER**
 • PRESS CLUTCH/BRAKE PEDAL FULLY
 • ENGAGE PARKING BRAKE
 • BLADE LEVER MUST BE "OFF"
 • MOVE SHIFT LEVER TO "N" NEUTRAL

13 **WARNING**
AVOID SERIOUS INJURY OR DEATH
 • READ ALL MANUALS AND INSTRUCTIONS FURNISHED WITH THE MACHINE.
 • MAKE SURE THAT SHIELDS, GUARDS, SWITCHES, AND OTHER SAFETY DEVICES ARE IN PROPER POSITION AND FUNCTIONAL.
 • CLEAR MOWING AREA OF WIRE, ROCKS AND OTHER OBJECTS THAT COULD CAUSE INJURY IF THROWN BY BLADE.
 • DO NOT ALLOW CHILDREN (PRE-TEENAGERS) ON MACHINE (EVEN WITH BLADE OFF) OR IN YARD WHEN MOWING. KEEP OTHERS SAFELY AWAY FROM THE OPERATING AREA.
 • LOOK DOWN AND BEHIND MACHINE BEFORE AND WHILE BACKING.
 • DO NOT MOW ON SLOPES, OR IN ANY AREA WHERE STABILITY OR TRACTION IS IN DOUBT. IF YOU CAN NOT BACK-UP A SLOPE, DO NOT MOW ON IT.
 • DO NOT MOW ACROSS FACE OF SLOPES. REDUCE SPEED AND AVOID SHARP TURNS ON SLOPES.
 • AVOID UPHILL STARTS. IF THE MACHINE IS STOPPED GOING UP A SLOPE, TURN BLADE OFF AND BACK DOWN THE SLOPE.
 • STOP BLADE BEFORE PUTTING FOOT ON GROUND OR LEAVING SEAT.
 • AVOID SUDDEN TURNS.

14 **WARNING**
Avoid serious injury or death
 • Read the operator's manual before using machine
 • Keep safety devices (guards, shields, switches, etc.) in place and working.
 • Disengage all drives, shut off engine and remove key before leaving operating zones.
 • Remove objects that could be thrown by the blade.
Amputation hazard
 • Do not mow when children or others are around.
 • Do not carry riders (especially children) even with the blades off. They may fall off or return for another ride when you are not expecting it.
 • Look down and behind before and while backing.
Fire hazard
 • Keep unit cleaned of debris
 • Allow engine to cool for at least 3 minutes before refueling.
Roll-over hazard
 • Go up and down slope, not across
 • If machine stops while going uphill stop the blades and back down slowly
 • Avoid sudden turns and slopes over 10°

15 **MOWER BELTS AND BLADES**

28" MOWER	
MOWER BELT	22252
MOWER BLADE	35635
30" MOWER	
MOWER BELT	22252
MOWER BLADE	18069
33" MOWER	
MOWER BELT	43844
MOWER BLADE	34168
42" MOWER	
MOWER BELT	28784
MOWER BLADE	26691

 USE ONLY GENUINE SNAPPER REPLACEMENT PARTS TO ASSURE THAT ORIGINAL STANDARDS ARE MAINTAINED.

16 **NOTICE**
 Remove battery before standing mower on end for more than 2 hours.

17 **Before starting engine**
 • Press clutch/brake pedal fully down
 • Engage parking brake
 • Blade lever must be off
 • Move shift lever to "N" neutral
DANGER
Carbon monoxide hazard
 • Only operate machine outdoors.
 • Avoid inhaling exhaust fumes.

18 **CAUTION** **Fire hazard**
 Before standing unit on end
 • Close cap vent
 • Remove tank if over 3/4 full.

19 **DANGER**
Amputation and thrown objects hazard
 • Keep hands and feet away from deck.
 • Do not operate mower unless discharge chute or entire grass catcher is in its proper place.

20 **CAUTION**
Explosion hazard
 • Positive (+) battery post must be to rear to prevent arcing.
 • Use only Snapper replacement battery to avoid acid damage.

DECALS

REF NO	PART NO	QTY	DESCRIPTION
1	7071916	1	DECAL, SNAPPER
2	7023982	1	DECAL, OHV (33" Kohler Engine Models)
3	7023980	1	DECAL, Back-Up Recoil (33" Kohler Engine Models)
4	7046218	1	DECAL, Height of Cut
5	7026831	1	DECAL, Danger (CPSC)
6	7046720	1	DECAL, Chute/Deflector Warning
7	7023996	1	DECAL, 28 Inch (Hi-Vac)
8	7022991	1	DECAL, 33 Inch (Hi-Vac)
9	7015691	1	DECAL, Battery Caution
10	7012358	1	DECAL, Battery
11	7029113	1	DECAL, Caution, Fuel (English)
12	7074481	1	DECAL, No Mow in Reverse
13	7046440	1	DECAL, Safety Instructions
14	7101111	1	DECAL, Warning, Safety Panel
15	7075607	1	DECAL, Service Parts, Domestic
16	7101109	1	DECAL, Remove Battery
17	7101112	1	DECAL, Danger, Safety Panel
18	7101107	1	DECAL, Caution, Fuel
19	7101108	1	DECAL, Caution, Battery
20	7101110	1	DECAL, Danger, Deck

DIFFERENTIAL, R. H. FENDER

Note: Unless noted otherwise, use the standard torque specifications

Mfg. No: 7800107

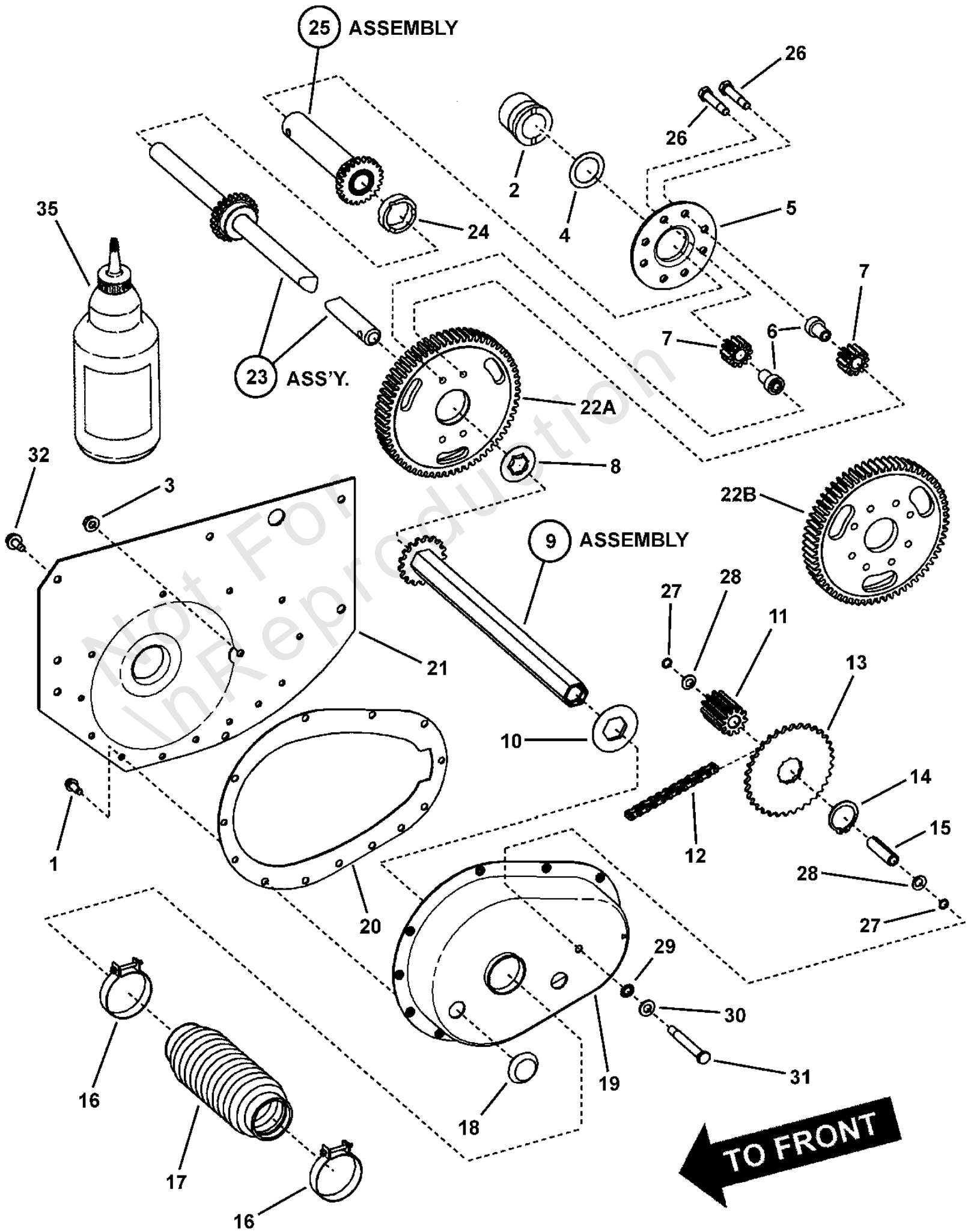

DIFFERENTIAL, R. H. FENDER

REF NO	PART NO	QTY	DESCRIPTION
1	7091819	13	SCREW, 1/4-20 x 5/8" Hex Washer Head Self-Tap -(Was 7090362)
2	7012296	1	BEARING, Axle (R. H. Fender)
2	7054372	1	BEARING-DX, Axle (R. H. Fender) -(includes 1-1/8" I.D. (DX) bearing)
3	7010969	1	NUT, 5/16-24 Flange Lock (Large)
4	7031079	1	WASHER, Thrust
5	7038067	1	PLATE, Differential -(Note: 4 holes offset - align properly to prevent binding.)
6	7022115	4, 8	SPACER, Pinion
7	7021127	4, 8	GEAR, Differential Pinion (12T 12P)
8	7011072	1	WASHER, Thrust
9	7051584	1	* ASSEMBLY, Drive Hex Tube
10	7010988	1	WASHER, Nylon
11	7200128	1	GEAR, 11 Tooth, 10 Pitch -(Was 7010964)
12	7010941	1	CHAIN, 46 Pitch (#35 Endless)
13	7021129	1	SPROCKET, 34T, 3/8P
14	7010965	1	RING, 1-3/16" External Retaining
15	7021128	1	SPACER, Differential Case
16	7012332	2	BOOT CLAMP, 2"
17	7075115	1	BOOT, Oil Seal (Short Axle)
18	7011024	2	PLUG, 1/2" Cup Insert
19	7037279	1	CASE, Transmission
20	7028762	1	GASKET, Transmission Case
21	7037280	1	FENDER, Right Hand (1.62" Dia. Hole)
22A	7021158	1	GEAR, 63 Tooth 10 Pitch (4 Hole)
22B	7027644	1	GEAR, 63 Tooth 10 Pitch (8 Hole)
23	7047763	1	KIT, Long Axle Structure (Includes spacer 7074431) -(Was 7047763)
24	7074431	1	SPACER, Differential Case
25	7057398	1	ASSEMBLY, Short Axle, 23T (Includes Gear)
26	7012333	4, 8	BOLT, 5/16-24 x 1-5/8" Hex Special Lock (Vibresist)
27	7011156	2	O-RING, 5/16"
28	7011782	2	WASHER, 5/16" Belleville
29	7090395	1	WASHER, 5/16" External Tooth Lock
30	7090188	1	WASHER, .34 x .69 x .08 Flat
31	7011042	1	SCREW, 5/16-24 x 2-5/8" Hex Head Cap
32	7090361	11	SCREW, 5/16-18 x 5/8" Hex Washer Self-Tap
35	7061017		GREASE, Transmission (24 oz. Required)
	7060411	1	KIT, Differential (4 Pinion)
	7060662	1	KIT, Differential (8 Pinion w/DX Bearing)
	7060412	1	KIT, Long & Short Axle (Includes items 23, 24, & 25)

Footnotes:

Note: * Assembly includes two bearings inside hex tube (p/n 7015140, not shown) & one nylon washer (p/n 7010988, item 10).

ELECTRICAL SYSTEMS (Briggs Magneto Ground)

Note: Unless noted otherwise, use the standard torque specifications

Mfg. No: 7800107

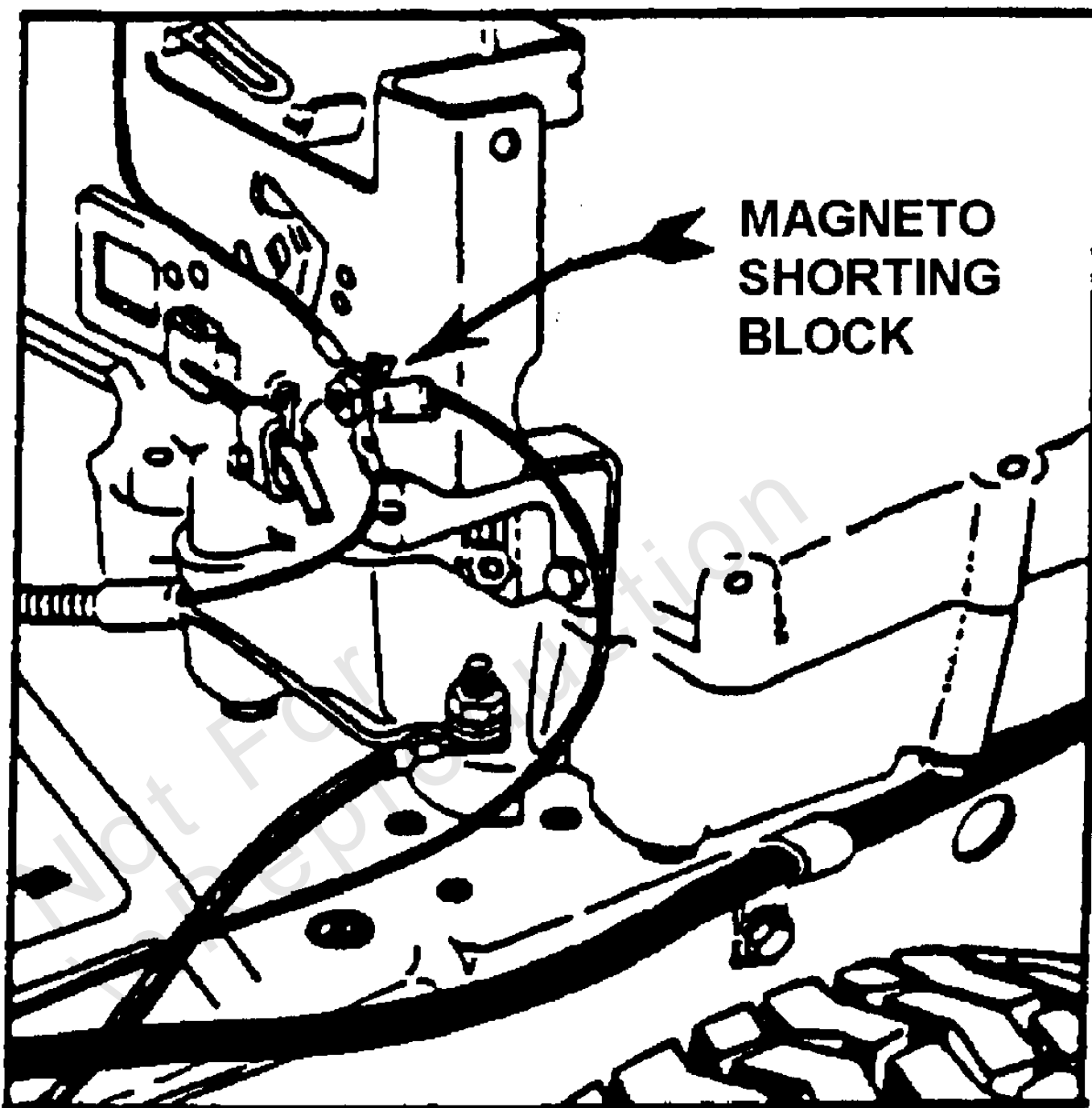

ELECTRICAL SYSTEMS (Briggs Magneto Ground)

REF NO	PART NO	QTY	DESCRIPTION
	-----		View shows engine magneto ground connection on throttle plate

Not For In Reproduction

ELECTRICAL SYSTEMS (For 13.5, 15, 16, 17 & 17.5HP Briggs)

REF NO	PART NO	QTY	DESCRIPTION
1	7060753	1	KIT, Battery, 12V, U-1-7RS, 220CCA Dry Charge Snapper No Spill
2	7075671	1	SOLENOID, Super-Trombetta
3	7022788	1	HARNESS, Starter Wiring (Briggs)
4	7074406	1	HARNESS, Ignition Wiring (Briggs)
5	7016168	1	HOLDER, Fuse (Includes Fuse)
	7016169	1	FUSE, 10 Amp
6	7028606	1	INTERLOCK MODULE, Briggs & Kohler
7	7028386	1	HARNESS (Deck Interlock Wiring)
8	7018524	1	SWITCH, Deck Interlock (NO)
9	7012444	1	COVER, Battery Cable
10	7019326	1	WIRE, Positive (Red, 17" long)
11	7026343	1	SWITCH, Ignition-Afterfire Solenoid
12	7090880	1	WASHER, 5/8" Internal Tooth Lock
13	7015438	1	NUT, 5/8-32 Hex
14	7011138	1	IGNITION KEY, Pair
15	7091122	3	SCREW, 1/4-20 x 1/2" Hex Washer Self-Tap -(Was 7090539)
16	7022886	1	SWITCH, Operator Presence Control (OPC) Traction (NC/NO)
17	7091576	8	NUT, 1/4-20 Hex, GR 5 or B
18	7090053	2	WASHER, 1/4" Internal Tooth Lock
19	7090072	2	SCREW, 1/4-20 x 5/8" Hex Head Cap, GR 5 -(Was 7027172)
20	7028027	1	WIRE, Negative, Black (15" long)
21	7028675	1	HARNESS, Operator Presence Control (OPC) Wire
22	7023354	1	SWITCH, Seat (NC) -(for use with 7075071 seat)
23	7012080	2	CABLE TIE, 7"
24	7090372	2	NUT, 1/4-20 Hex Center Lock, GR 5 or B
25	7014451	1	CABLE TIE
26	7012485	2	RETAINER, 1/4" Bolt

ENGINE, MUFFLER & DRIVE DISC

Note: Unless noted otherwise, use the standard torque specifications

Mfg. No: 7800107

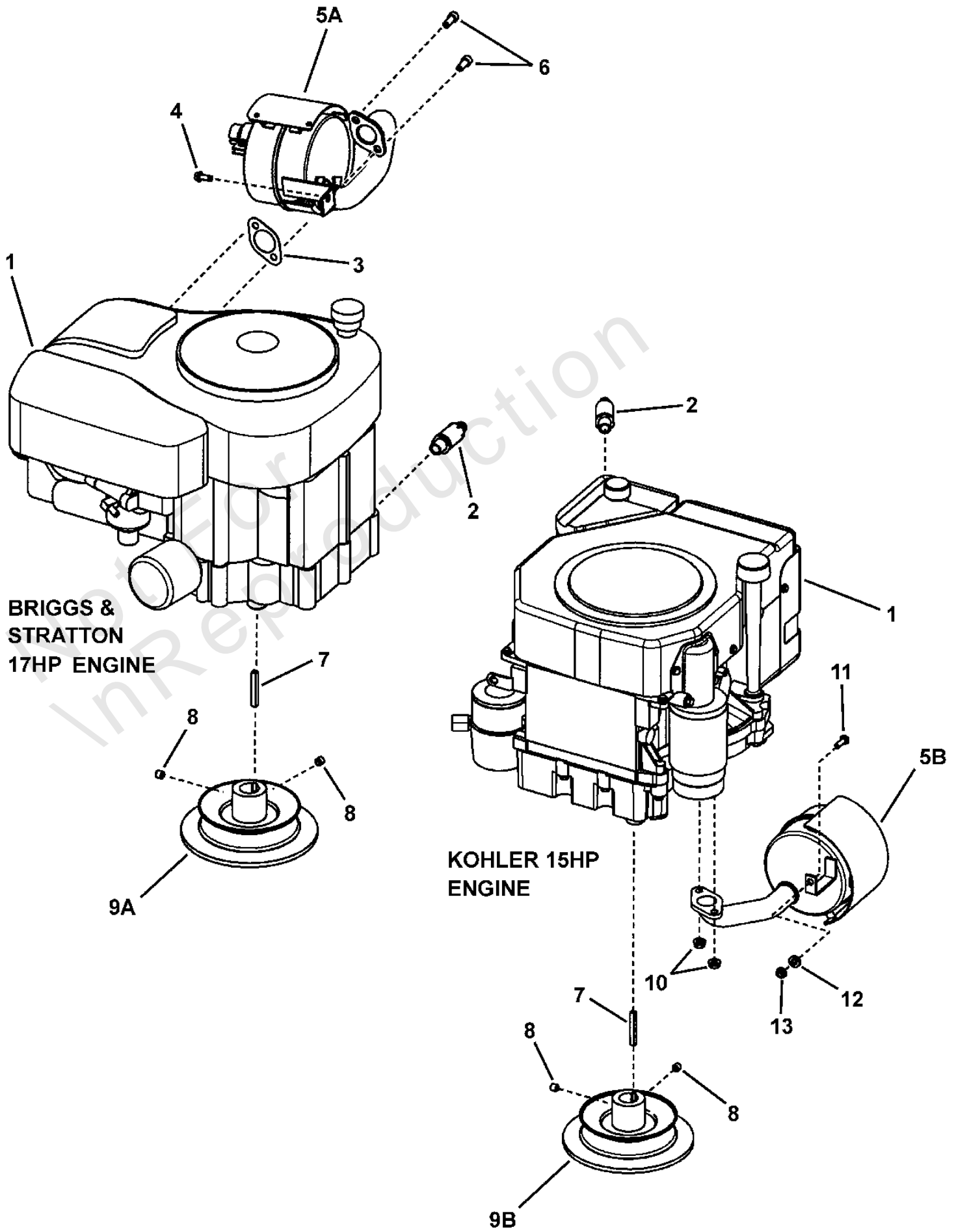

ENGINE, MUFFLER & DRIVE DISC

REF NO	PART NO	QTY	DESCRIPTION
1	28B702-1154-E1	1	* ENGINE, 9HP Briggs (Mod 28B702-1154-E1) -(recoil start)
1	214707-0113-E1	1	* ENGINE, 10HP Briggs (Mod 214707-0113-E1) -(electric start)
1	21A902-0127-E1	1	* ENGINE, 11HP Briggs (Mod 21A902-0127-E1) -(recoil start)
1	21A907-0124-E1	1	* ENGINE, 11HP Briggs (Mod 21A907-0124-E1) -(electric start)
1	GXV340-K2DET3	1	* ENGINE, 11HP Honda (Mod GXV340, Type K2DET3) -(electric start)
1	217802-0113-E1	1	* ENGINE, 11.5HP Briggs (Mod 217802-0113-E1) -(recoil start)
1	217802-3113-G1	1	* ENGINE, 11.5HP Briggs (Mod 217802-0113-G1)
1	219907-0131-B1	1	* ENGINE, 12.5HP Briggs (Mod 219907-0131-E1) -(electric start)
1	219977-0146-G1	1	* ENGINE, 12.5HP Briggs (Mod 219977-0146-G1) -(electric start)
1	219977-0174-B1	1	* ENGINE, 12.5HP Briggs (Mod 219977-0174-B1) -(electric start)
1	21A907-0128-E1	1	* ENGINE, 13HP Briggs (Mod 21A907-0128-E1) -(electric start)
1	GXV39K-1DET3	1	* ENGINE, 13HP Honda (Mod GXV39K, Type 1DET3) -(electric start)
1	21B907-0137-E1	1	* ENGINE, 13.5HP Briggs (Mod 21B907-0137-E1) -(electric start)
1	284H07-0115-E1	1	* ENGINE, 15HP Briggs (Mod 284H07-0115-E1) -(electric start)
1	CV15ST, PS-41584	1	* ENGINE, 15HP Kohler (Mod CV15ST, Type PS-41584) -(electric start)
1	31F777-0115-E1	1	* ENGINE, 16 or 17HP Briggs (Mod 31F777-0115-E1) -(electric start)
1	31G777-0156-G1	1	* ENGINE, 17.5HP Briggs Intek w/AVS (Mod 31G777-0156-G1) -(electric start)
1	31G777-0297-B1	1	* ENGINE, 17.5HP Briggs Intek w/AVS (Mod 31G777-0297-B1) -(electric start)
2	7027972	1	ASSEMBLY, Oil Valve
3	7015352	1	GASKET, Exhaust
4	7091819	2	SCREW, 1/4-20 x 5/8" Hex Washer Head Self-Tap -(Was 7090362)
5A	7074453	1	MUFFLER, w/Heat Shield (Briggs 11 thru 17.5HP)
5B	7019358	1	MUFFLER, (Kohler 14 & 15HP)
6	7091738	2	SET SCREW, 5/16-18 x 3/4" Socket Head, GR8
7	7010210	1	KEY, 1/4" Square x 2" Long
8	7090132	2	SET SCREW, HRSS, 3/8-16 x 3/8"
9A	7072658	1	WELDMENT, 5.75" O.D. Drive Disc -(used on 28" Decks)
9B	7074187	1	WELDMENT, 5.25" O.D. Drive Disc -(used on 33" Deck Models)
10	7090585	2	NUT, 5/16-18 Hex Flange Lock, GR 5
11	7091495	1	SCREW, 1/4-20 x 3/4" Hex Head Cap, GR 5
12	7013849	1	SPACER, .33 x .63 x .156
13	7091065	1	NUT, 1/4-20 Hex Flange Lock
14	7091576	1	NUT, 1/4-20 Hex, GR 5 or B (not shown) -(attaches to starter terminal on Briggs 12.5, 17 & 17.5HP)

Footnotes:

Note: * Purchase engine parts from engine manufacture dealer.

FRONT END, STEERING

Note: Unless noted otherwise, use the standard torque specifications

Mfg. No: 7800107

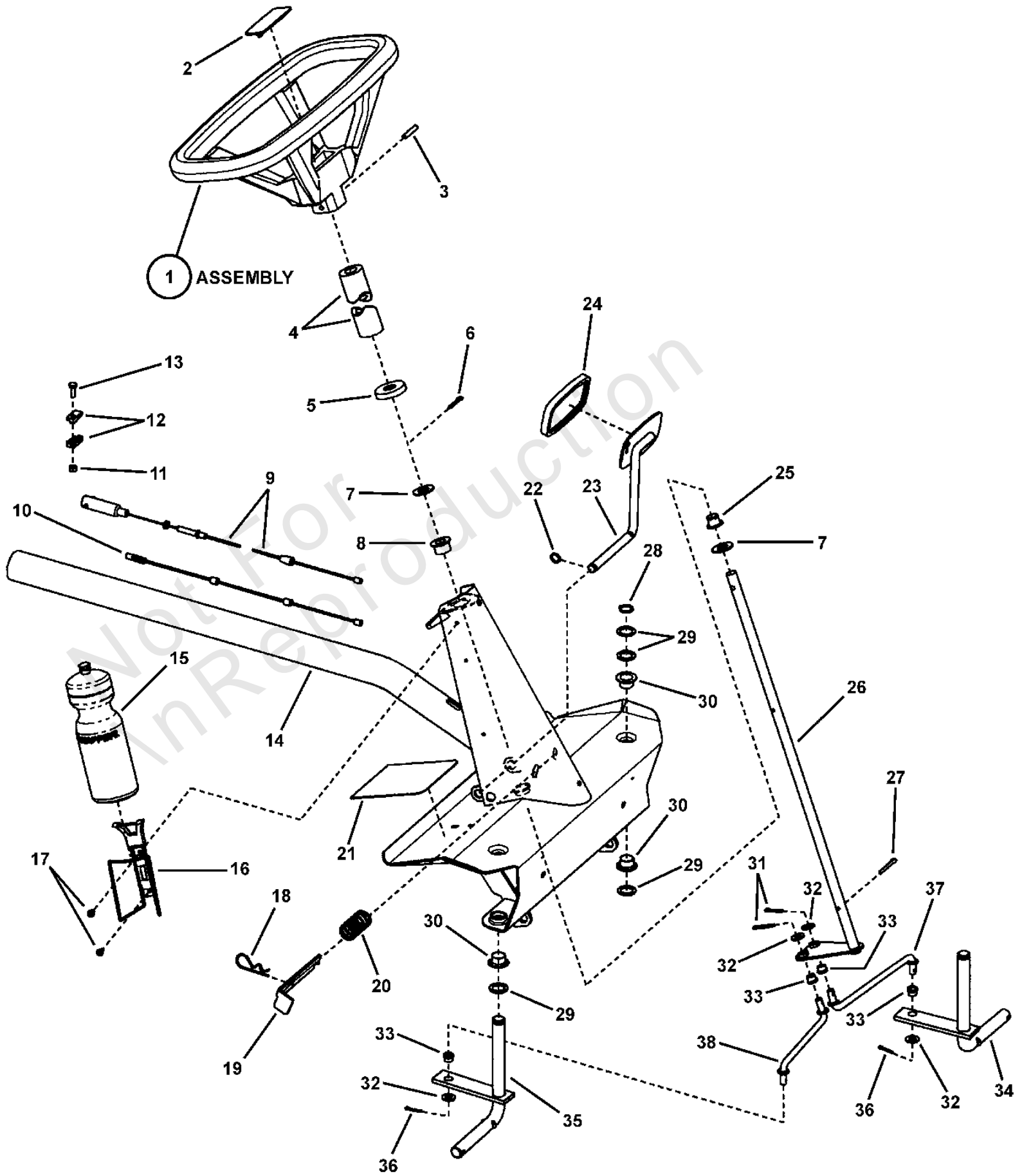

FRONT END, STEERING

REF NO	PART NO	QTY	DESCRIPTION
1	7058030	1	ASSEMBLY, Steering Wheel (for 5/8" shaft) -(Includes item 2)
2	7023781	1	LOGO, Steering Wheel
3	7013862	1	ROLL PIN, 1/4 x 1-1/2"
4	7023667	1	FOAM COVER, Steering Shaft
5	7023671	1	COVER, Steering Shaft
6	7090296	1	PIN, 3/16 x 1" Cotter
7	7090183	2	WASHER, .66 x 1.31 x .09 Flat
8	7046158	1	BUSHING, Nylon
9	7101192	1	CABLE, Brake, Snap-In -(replaces 7072648)
10	7022449	1	CABLE, Clutch/Brake (54.32" long) -(used on 25" & 28" Decks)
10	7074131	1	CABLE, Clutch/Brake (55" long) -(used on 33" Decks)
11	7090372	1	NUT, 1/4-20 Hex Center Lock, GR 5 or B
12	7034174	2	CONNECTOR, Cable
13	7091495	1	SCREW, 1/4-20 x 3/4" Hex Head Cap, GR 5
14	7054378	1	WELDMENT, Front Axle, Narrow -(used on 25" & 28" Decks)
14	7053266	1	WELDMENT, Front Axle, Wide -(used on 33" Decks)
15	7074561	1	BOTTLE, Water
16	7074560	1	HOLDER, Bottle (Wire)
17	7090913	2	SCREW, #10-24 x 1/2" Hex Washer Self-Tap (Torx)
18	7011714	1	HAIR PIN 2-1/4"
19	7038243D	1	LATCH, Parking Brake
20	7015444	1	SPRING, Parking Brake Latch
21	7014049	2	FOOT PAD, Short (5.5" x 4.7")
21	7014048	2	FOOT PAD, Long (5.5" x 9.5")
22	7010776	1	RING, 1/2" External Retaining (Heavy Duty)
23	7047888BM	1	WELDMENT, Clutch Pedal
24	7011815	1	PAD, Pedal
25	7010694	1	BUSHING, Nylon
26	7046232	1	WELDMENT, Steering Shaft
27	7091515	1	PIN, 3/16 x 1-1/2" Cotter -(Was 7090753)
28	7010746	2	RING, 5/8" External Retaining
29	7010935	6	WASHER, .77 x 1.13 x .06 Flat
30	7010986	4	BEARING, Nylon
31	7091516	2	PIN, 5/32 x 1" Cotter -(Was 7090364)
32	7090122	4	WASHER, 3/8" Flat SAE
33	7013321	4	BUSHING, Tie Rod
34	7041687	1	WELDMENT, King Pin, Left Hand
35	7041688	1	WELDMENT, King Pin, Right Hand
36	7091598	2	PIN, 1/8 x 3/4" Cotter -(Was 7090365)
37	7013023	1	TIE ROD, Left Hand (7.41" long)
37	7012541	1	TIE ROD, Left Hand (9.91" long)
38	7012933	1	TIE ROD, Right Hand (7.41" long)
38	7012540	1	TIE ROD, Right Hand (9.91" long)

FUEL TANK & SEAT

Note: Unless noted otherwise, use the standard torque specifications

Mfg. No: 7800107

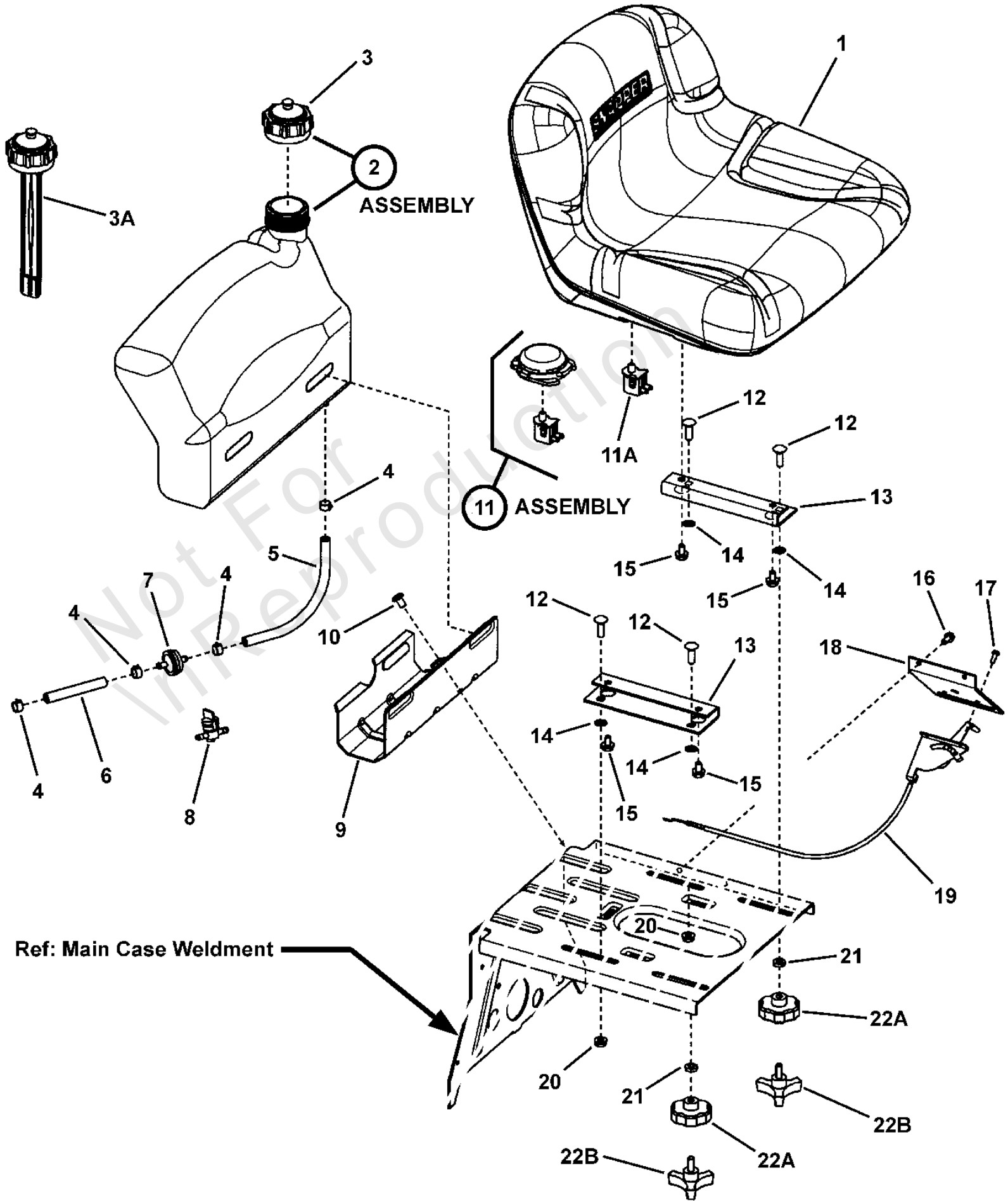

FUEL TANK & SEAT

REF NO	PART NO	QTY	DESCRIPTION
1	7075071	1	SEAT, Operator (11.58" tall) (shown) (Michigan V-2400 Series) -(used on 12HP & Higher Models)
1	7075376	1	SEAT, Operator (9.30" tall) (Michigan V-2300 Series) -(used on 7084840 (2811523BV)
2	7051905	1	ASSEMBLY, Fuel Tank (Includes item 3) -(used on 9, 10 & 11.5HP Models)
2	7052435	1	ASSEMBLY, Fuel Tank with Gauge (Includes item 3A) -(used on 12, 12.5, 15, 17 & 17.5 HP Models)
3	7012515	1	CAP, Fuel Tank
3A	7019377	1	CAP, Fuel Tank w/Gauge
4	7029900	4	CLAMP, Fuel Line -(replaces 7012222 clamp)
5	1734994	1	HOSE, Fuel (1/4" I.D. x 8-1/2" long) -(used on Briggs 8-17.5 HP; Was 7076272)
5	7012912	1	HOSE, Fuel (1/4" I.D. x 12-1/2" long) -(used on Kohler Models only)
5	7041996	1	HOSE, Fuel (1/4" I.D. x 6-1/2" long) -(used on Kohler Models only)
6	7077351	1	HOSE, Fuel (1/4" I.D. x 3-1/2" long)
7	7014359	1	FILTER, Fuel (In-Line)
8	7024507	1	VALVE, Fuel Shut-Off (Accessory)
9	7033377	1	BRACKET, Fuel Tank (Rear)
10	7091542	2	SCREW, 5/16-18 x 1/2" Pan Head Self-Tap (Torx #T-40)
11	7029211	1	SWITCH, Seat, Quick Mount (NC) -(used on seat, p/n 7028650)
11A	7023354	1	SWITCH, Seat (NC)
12	7091303	4	BOLT, 5/16-18 x 1" Square Neck Carriage, GR 5 YZ -(Was 7091714)
13	7075018	2	BRACKET, Seat
14	7011791	4	RETAINER, 5/16" Bolt
15	7091038	2	BOLT, 5/16-18 x 1/2" Hex Flange Nyloc
16	7091122	2	SCREW, 1/4-20 x 1/2" Hex Washer Self-Tap -(Was 7090539)
17	7090913	2	SCREW, #10-24 x 1/2" Hex Washer Self-Tap (Torx)
18	7033470	1	PLATE, Throttle Control
19	7022751	1	CONTROL, Throttle (23.6" long) (Briggs Engines)
19	7074320	1	CONTROL, Throttle (34.6" long) (Kohler Engines)
19	7075089	1	CONTROL, Throttle (34.6" long) (Honda Engines)
20	7090672	2	NUT, 5/16-18 Hex Flange Top Lock -(or 7090951)
21	7013849	2	SPACER, .33 x .63 x .156
22A	7023735	2	KNOB, Fluted, 5/16-18 internal thread (2.15 O.D.)
22B	7023191	2	KNOB, 3-Prong, 5/16-18 x 3/4" external thread -(used on seat, p/n 7028650)

GEAR SHIFTER ASSEMBLY

Note: Unless noted otherwise, use the standard torque specifications

Mfg. No: 7800107

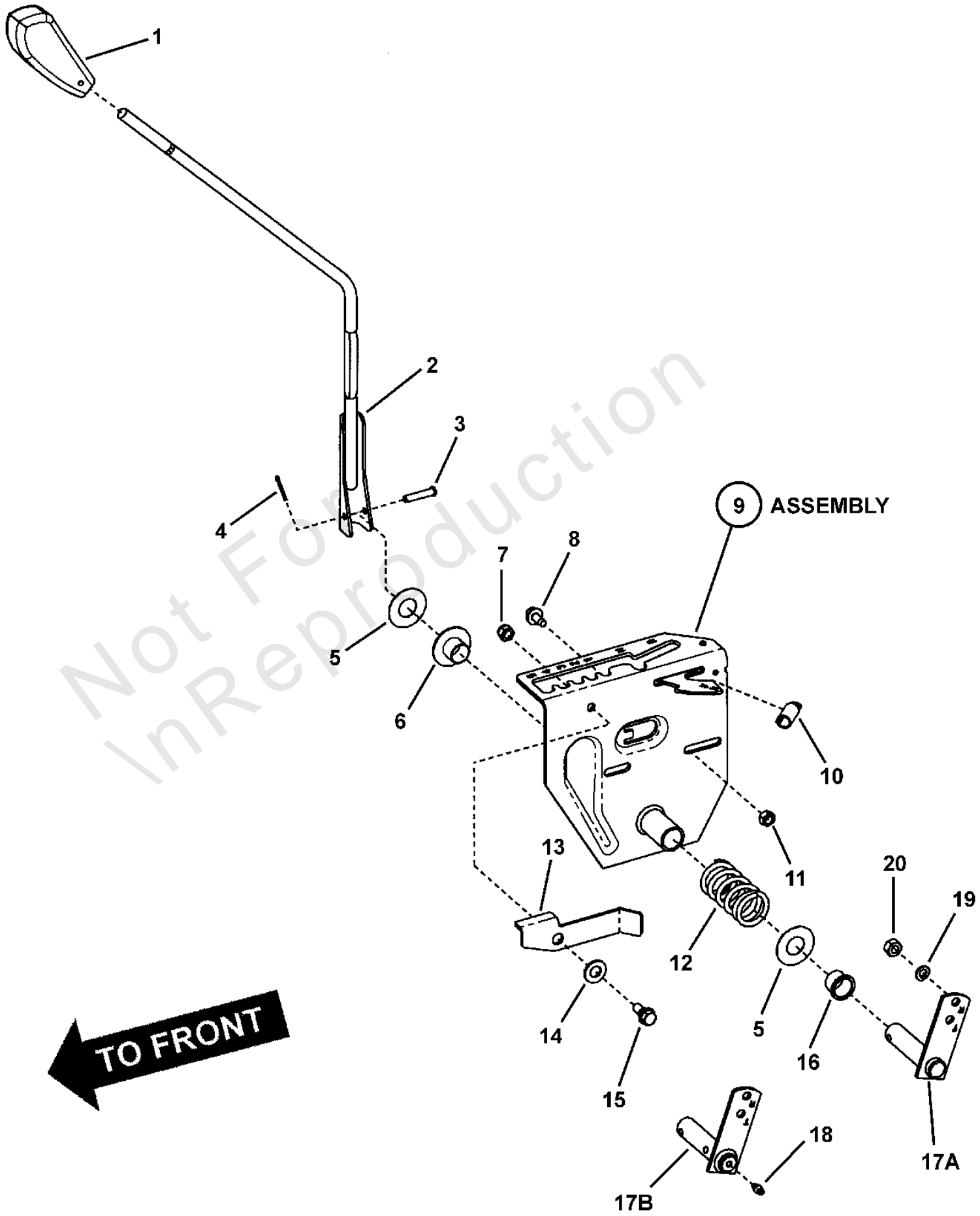

GEAR SHIFTER ASSEMBLY

REF NO	PART NO	QTY	DESCRIPTION
1	7023656	1	GRIP, Shift Handle
2	7059212	1	WELDMENT, Shift Handle
3	7023914	1	PIN, 1/4 x 1-3/4" Tapered Clevis
4	7091597	1	PIN, 3/32 x 3/4" Cotter -(Was 7090037)
5	7031036	2	WASHER, Thrust
6	7019245	1	BUSHING, 3/4 x 1.62 Flange (Nylon)
7	7091298	1	NUT, 5/16-18 Hex Nyloc
8	7090361	1	SCREW, 5/16-18 x 5/8" Hex Washer Self-Tap
9	7058763	1	* ASSEMBLY, Speed Adjustment Latch
10	7026292	1	SPRING -(part of Speed Adjustment Latch Ass'y)
11	7091511	1	NUT, 5/16-18 Hex, GR 5 or B -(Was 7090196)
12	7010754	1	SPRING, Shift Detent
13	7073289	1	LEVER, Over-Ride
14	7091595	1	WASHER, .47 x .92 x .065 Flat
15	7015761	1	SHOULDER BOLT, 5/16-18
16	7019246	1	BUSHING, 3/4 x I.O. Flange (Nylon)
17A	7040598	1	WELDMENT, Arm, Shift Handle
17B	7043201	1	WELDMENT, Arm, Shift Handle (w/grease ftg. Hole)
18	7010817	1	LUBE FITTING, 3/16" Press-In -(used with 7043201)
19	7091315	1	WASHER, .32 x .58 x .08 Split Lock
20	7091297	1	NUT, 5/16-24 Hex, GR 5

Footnotes:

Note: * Assembly is comprised of: Shift Detent Weldment (7041232), Shoulder Rivet (7029022), Reverse Stop (7073218) & item 10.

No
Diagram
Available
Parts List
Only

HARDWARE BAGS

REF NO	PART NO	QTY	DESCRIPTION
	7063039	1	HARDWARE BAG (Incl. the 17 items below) -(for manual start models)
	7011024	2	PLUG, 1/2" Cup Insert
	7013321	2	BUSHING, Tie Rod
	7013849	2	SPACER, .33 x .63 x .156
	7013862	1	ROLL PIN, 1/4 x 1-1/2"
	7023667	1	FOAM COVER, Steering Shaft
	7023671	1	COVER, Steering Shaft
	7090372	2	NUT, 1/4-20 Hex Center Lock, GR 5 or B
	7091038	4	BOLT, 5/16-18 x 1/2" Hex Flange Nyloc
	7091516	2	PIN, 5/32 x 1" Cotter
	7090296	1	PIN, 3/16 x 1" Cotter
	7090122	2	WASHER, 3/8" Flat SAE
	7075018	2	BRACKET, Seat
	7091714	4	BOLT, 5/16-18 x 1" Square Neck Carriage, GR 5
	7023735	2	KNOB, Seat Adjusting, 5/16-18 thread
	7011791	4	RETAINER, 5/16" Bolt
	7023354	1	SWITCH, Seat (NC)
	7090951	2	NUT, 5/16-18 Hex Large Flange Center Lock
	7061872	1	HARDWARE BAG (Includes the 15 items below)
	7011024	2	PLUG, 1/2" Cup Insert
	7013321	1	BUSHING, Tie Rod
	7013849	2	SPACER, .33 x .63 x .156
	7013862	1	ROLL PIN, 1/4 x 1-1/2"
	7023667	1	FOAM COVER, Steering Shaft
	7023671	1	COVER, Steering Shaft
	7090372	2	NUT, 1/4-20 Hex Center Lock, GR 5 or B
	7091038	2	BOLT, 5/16-18 x 1/2" Hex Flange Nyloc
	7091516	2	PIN, 5/32 x 1" Cotter
	7090296	1	PIN, 3/16 x 1" Cotter
	7090122	1	WASHER, 3/8" Flat SAE
	7090913	2	SCREW, #10-24 x 1/2" Hex Washer Self-Tap (Torx)
	7023191	2	KNOB, Seat Adjusting (5/16-18 thread)
	7028395	2	SPACER, Pivot
	7029211	1	SEAT SWITCH, Quick Mount (NC)
	7063292	1	HARDWARE BAG (Incl. items 1-12 above & the 6 items below)
	7023735	2	KNOB, Seat Adjusting, 5/16-18 thread
	7023354	1	SWITCH, Seat (NC)
	7075018	2	BRACKET, Seat
	7091714	4	BOLT, 5/16-18 x 1" Square Neck Carriage, GR 5
	7011791	4	RETAINER, 5/16" Bolt
	7090951	2	NUT, 5/16-18 Hex Large Flange Center Lock
	7061093	1	HARDWARE BAG (Incl. the 9 items below)
	7017176	1	DECAL, Recycling Speeds
	7017328	1	DECAL, Height of Recycling Cut
	7022325	1	DECAL, Cut Height
	7090001	3	BOLT, 5/16-18 x 3/4" Short Neck Carriage, GR 5
	7090188	3	WASHER, 5/16" Flat
	7090392	2	SCREW, 1/2-20 x 1" Hex Head Cap, GR 5
	7091537	3	WING NUT, 5/16-18 -(Was 7090492)
	7090509	2	WASHER, 1/2" Internal Tooth Lock

No
Diagram
Available
Parts List
Only

HARDWARE BAGS

REF NO	PART NO	QTY	DESCRIPTION
	7090559	2	NUT, 1/2-20 Hex Jam

Not For In Reproduction

LEFT HAND FENDER & BEARING

Note: Unless noted otherwise, use the standard torque specifications

Mfg. No: 7800107

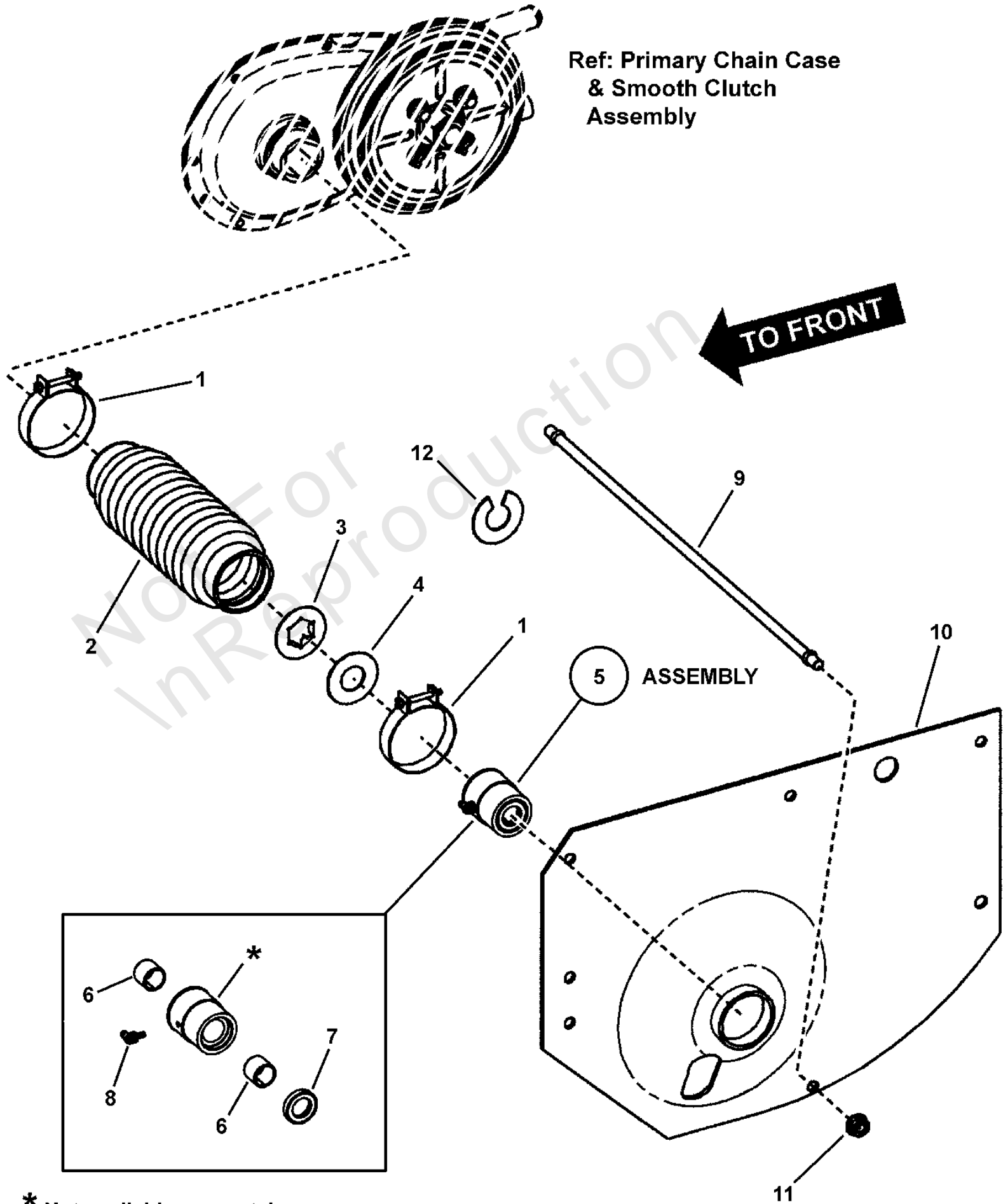

* Not available separately,
order 7052827 (Assembly, DX Bearing)

LEFT HAND FENDER & BEARING

REF NO	PART NO	QTY	DESCRIPTION
1	7012332	2	BOOT CLAMP, 2"
2	7075115	1	BOOT, Rear Axle, Thick Flange
3	7011072	1	WASHER, Thrust
4	7011071	1	THRUST WASHER
5	7052827	1	ASSEMBLY, DX Bearing (incl. next 3 items shown below)
6	7074182	2	BEARING, DX
7	7074500	1	SEAL, Axle (Dust/Grease)
8	7075848	1	FITTING, Lube, 45 Degree, 3/16" w/Hex (long shank) -(or 7013324)
9	7011070	1	TIE ROD (5/16-24 thread - both ends)
10	7037285	1	FENDER, Left Hand (1.628" I. D. Hole)
11	7010969	1	NUT, 5/16-24 Flange Lock (Large)
12	7012271	1	WASHER, Shim -(or quantity as required)

Not For InReproduction

MAIN CASE & L.H. FENDER

Note: Unless noted otherwise, use the standard torque specifications

Mfg. No: 7800107

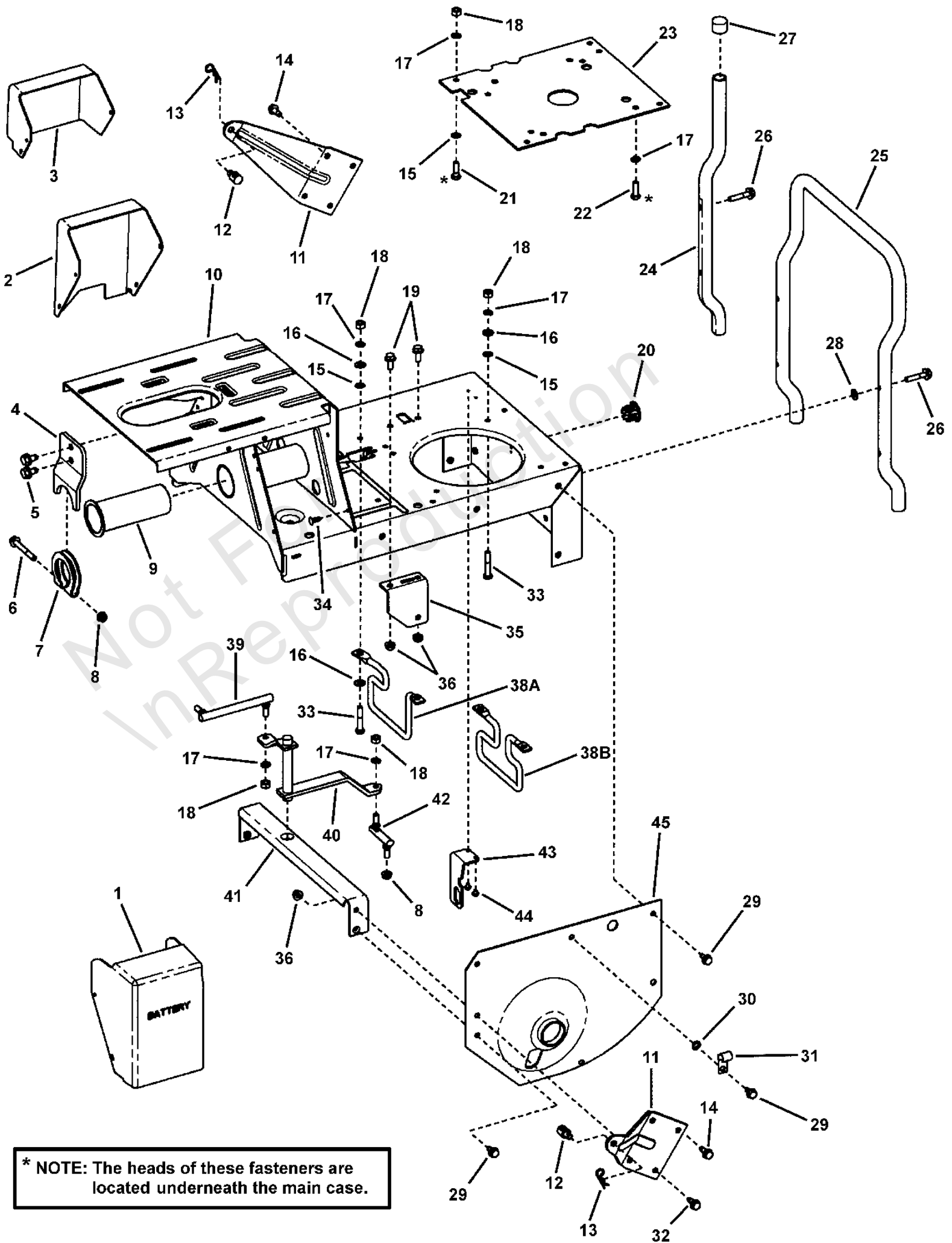

MAIN CASE & L.H. FENDER

REF NO	PART NO	QTY	DESCRIPTION
1	7028990	1	COVER, Battery
2	7028989	1	COVER, Switch
3	7073268	1	COVER, Solenoid
4	7074210	1	BRACKET, Belt Adjuster
5	7091198	2	SCREW, 3/8-16 x 5/8" Hex Washer Self-Tap
6	7090358	1	SCREW, 5/16-24 x 2-1/2" Hex Head Cap, GR 5
7	7031100	1	TUBE CLAMP
8	7010969	2	NUT, 5/16-24 Flange Lock (Large)
9	7074650	1	BUSHING, Pivot -(Was 7022509)
10	7053697	1	WELDMENT, Main Case (Standard) (shown)
11	7034299	2	WING, Rear
12	7028200	2	SWIVEL, Adjustable
13	7091503	2	HAIR PIN, 3/32 x 1-1/2"
14	7090793	4	SCREW, 5/16-18 x 3/4" Hex Washer Self-Tap
15	7011791	4	RETAINER, 5/16" Bolt
16	7091296	4	WASHER, 5/16" Flat
17	7091315	7	WASHER, .32 x .58 x .08 Split Lock
18	7091297	7	NUT, 5/16-24 Hex, GR 5
19	7090595	2	BOLT, 5/16-18 x 3/4" Hex Flange Lock, GR 5
20	7024998	3	PLUG, 1" Hole -(Used on Euro models only)
21	7090238	4	SCREW, 5/16-24 x 1" Hex Head Cap, GR 5
22	7077692	4	BOLT, M8-1.25 x 25mm, Self-Tap (Kohler)
23	7074946	1	PLATE, Engine (Kohler Engine)
24	7030798	2	BUMPER, Rear
25	7036367	1	BUMPER (1-Piece) (33" Deck)
26	7090484	4	SCREW, 5/16-18 x 1-1/2" Hex Washer Self-Tap
27	7010153	2	CAP, Bumper
28	7090188	2	WASHER, 11/32" Flat
29	7090361	14	SCREW, 5/16-18 x 5/8" Hex Washer Self-Tap
30	7090391	1	WASHER, 5/16" Internal Tooth Lock
31	7012652	1	CLIP, Wire
32	7091318	1	SCREW, 5/16-18 x 3/4" Hex Head Cap, GR 5 -(Was 7090206)
33	7091513	4	SCREW, 5/16-24 x 1-3/4" Hex Head Cap, GR 5
34	7091272	7	FASTENER, 1/4" Ratchet
35	7047189	1	BRACKET, Drive Support
36	7090585	6	NUT, 5/16-18 Hex Flange Lock, GR 5
38A	7017653	1	BELT GUIDE, 25 & 28 (5.74" Bolt Pattern, 4.74" Belt Gap)
38B	7036418	1	BELT GUIDE, 33" (5.74" Bolt Pattern, 5.0" Belt Gap) -(used on 7800107 & 7800254 models)
39	7023676	1	SHIFT LINK, Long (5/16-24 both ends)
40	7041384	1	WELDMENT, Shift Arm
41	7033799	1	CROSS BRACE
42	7011018	1	SHIFT LINK, Short (5/16-24 thread)
43	7073735	1	BRACKET, Switch
44	7090981	2	SCREW, #10-32 x 1/4" Hex Washer Self-Tap
45	7037285	1	FENDER, Left Hand (1.628" I. D. Hole)

PRIMARY CHAIN CASE & SMOOTH CLUTCH

Note: Unless noted otherwise, use the standard torque specifications

Mfg. No: 7800107

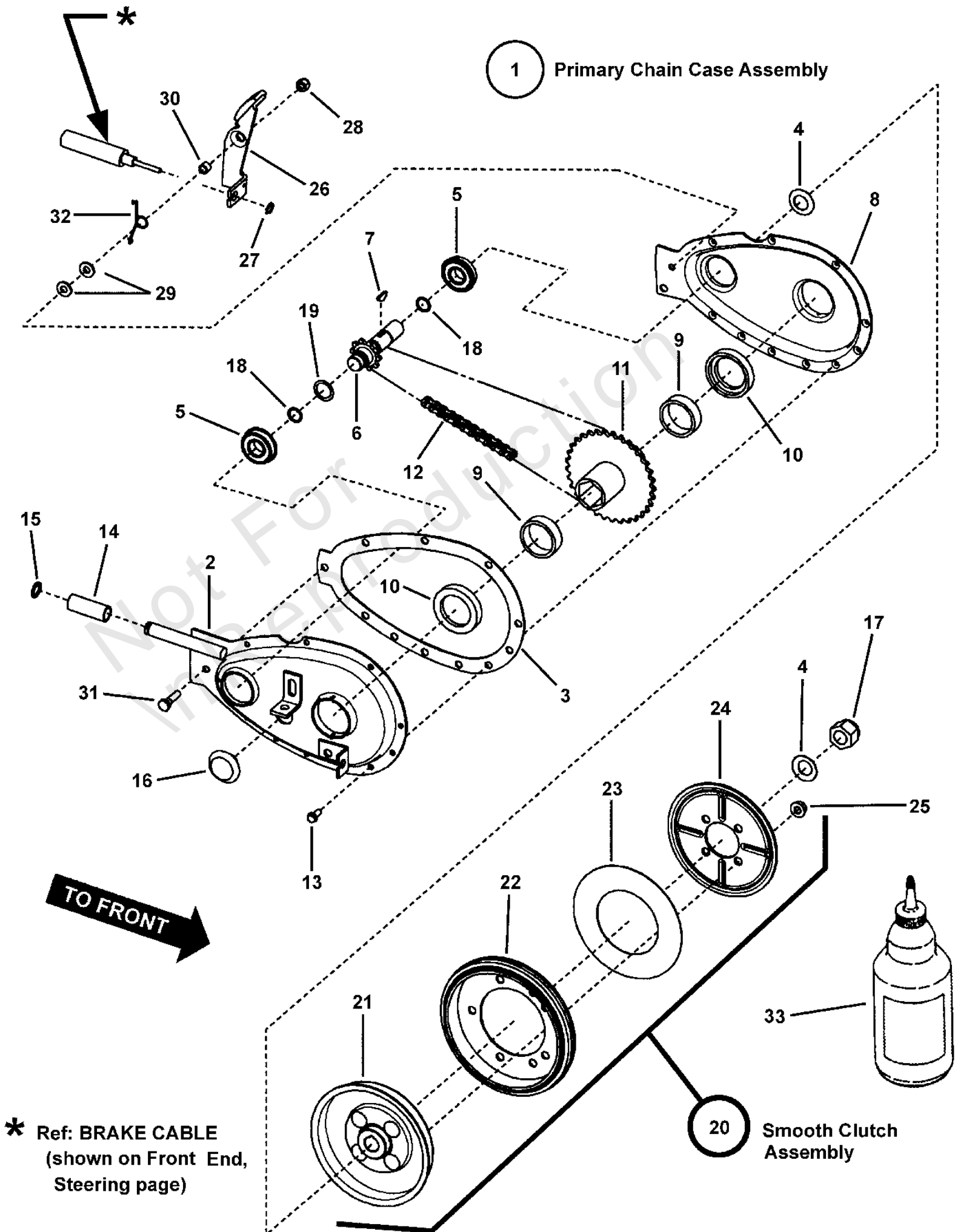

PRIMARY CHAIN CASE & SMOOTH CLUTCH

REF NO	PART NO	QTY	DESCRIPTION
1	7052683	1	ASSEMBLY, Primary Chain Case -(Includes the following 16 items)
2	7041136	1	WELDMENT, Primary Chain Case Half, Right Hand
3	7028761	1	GASKET, Primary Chain Case
4	7011121	2	WASHER, 5/8" Belleville
5	7010756	2	BEARING, .625 x 1.37 x .435
6	7018963	1	WELDMENT, Sprocket & Shaft
7	7010614	1	KEY, #5 Woodruff
8	7039778	1	PRIMARY CHAIN CASE HALF, Left Hand
9	7010942	2	BEARING, Needle 1.355" ID x 1.6245" OD x .5" Wide
10	7011086	2	THRUST WASHER, Nylon
11	7040355	1	WELDMENT, Hub & Sprocket
12	7010941	1	CHAIN, 46 Pitch (#35 Endless)
13	7090917	10	SCREW, 10-24 x 1/2" Hex Washer Self-Tap -(Was 7090307)
14	7022785	1	ROLLER, 1-3/8 Long
15	7010776	1	RING, 1/2" External Retaining (Heavy Duty)
16	7011024	1	PLUG, 3/4" Cup Insert
17	7091505	1	NUT, 5/8-18 Hex Nyloc
18	7019260	2	O-RING, 1/2 x 5/8"
19	7027981	1	WASHER, Shim .625 x .875
20	7053114	1	ASSEMBLY, Smooth Clutch (non-asbestos) -(Includes the following 5 items)
21	7059443	1	HUB, Driven Disc (assembly) -(Was 7054243)
22	7053103	1	DISC, Driven (rubber tire bonded to rim)
23	7014523	1	THRUST WASHER
24	7032331	1	PLATE, Drive Disc
25	7092081	4	NUT, 5/16-24 Hex Flange Lock -(Was 7090480, center lock flange nut)
26	7052497	1	ASSEMBLY, Brake Lever (Includes brake pad & rivet)
27	7012313	1	RING, 3/8" External Retaining
28	7090303	1	NUT, 1/4-28 Hex Top Lock
29	7091294	2	WASHER, .28 x .63 x .06 Flat, GR 5
30	7072593	1	* SPACER, Brake Arm Pivot (.418/.403 long) -(Was 7010916 (.300/.285 long))
31	7091504	1	SCREW, 1/4-28 x 1" Hex Head Cap, (Washer Face) GR 5
32	7072406	1	* SPRING, Torsional Brake Return
33	7061017		** GREASE, Transmission (Use 2 oz. Maximum)

Footnotes:

NOTE: ** Maximum capacity of chain case before causing leakage at bearing is 2 oz. DO NOT OVERFILL!
Note: * Brake return replacement kit (7061197) is made of items 30 & 32.

RAILS, LIFT ARMS & CAM LIFT

Note: Unless noted otherwise, use the standard torque specifications

Mfg. No: 7800107

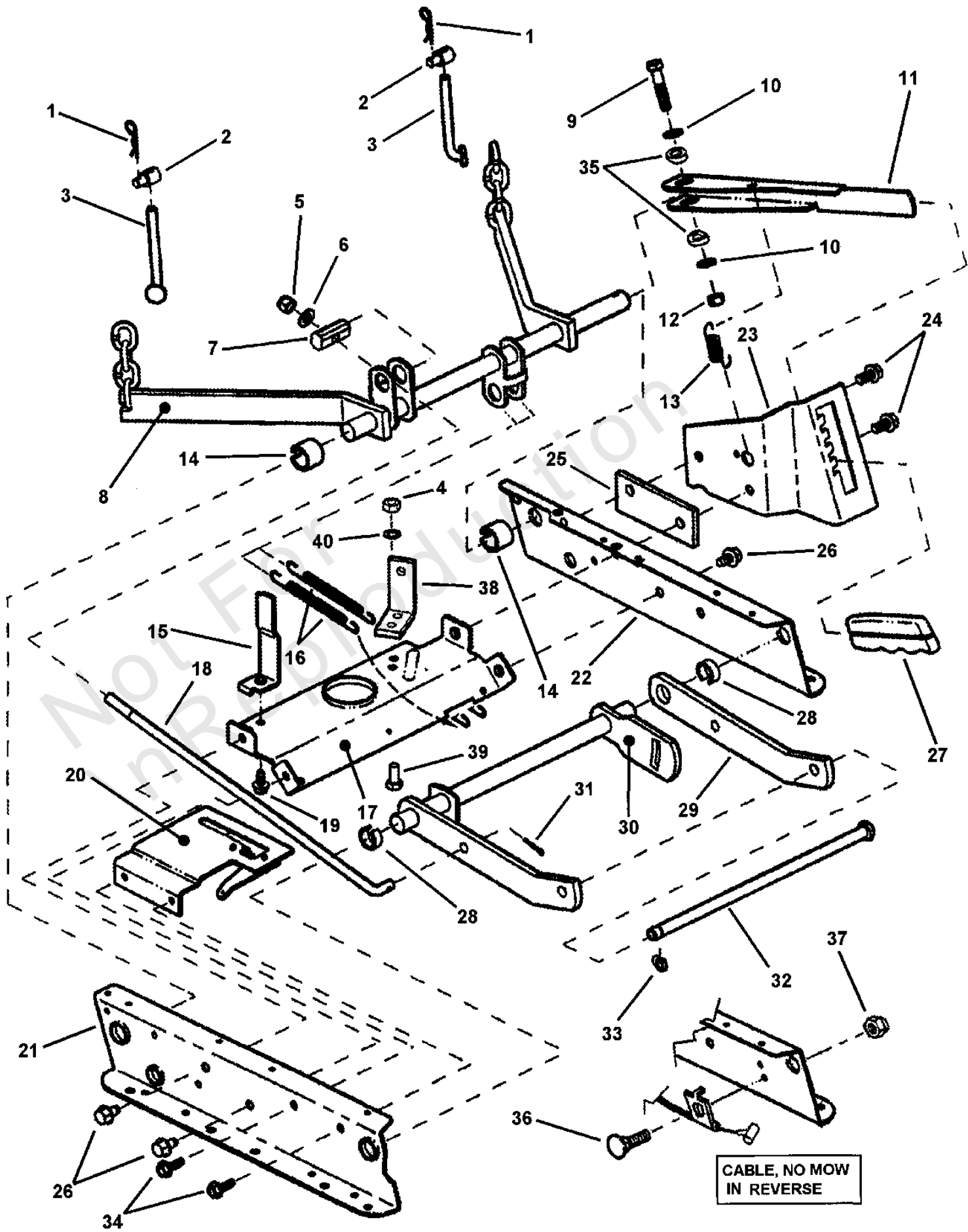

RAILS, LIFT ARMS & CAM LIFT

REF NO	PART NO	QTY	DESCRIPTION
1	7091503	2	HAIR PIN, 3/32 x 1-1/2"
2	7028200	2	SWIVEL, Adjustable
3	7028728	2	ADJUSTER, Chain (5/16-18 thread)
4	7091297	2	NUT, 5/16-24 Hex -(Was 7090223)
5	7090854	1	NUT, 3/8-24 Hex Nyloc
6	7090122	1	WASHER, 3/8" Flat SAE
7	7034213	1	PIVOT, Leveling
8	7059324	1	WELDMENT, Rear Lift Arm
9	7090483	1	SCREW, 3/8-24 x 1-3/4" Hex Head Cap, GR 5
10	7032030	2	WASHER, 13/32 x 1-1/4" Flat
11	7046155	1	LEVER, Height of Cut
12	7090289	1	NUT, 3/8-24 Hex Center Lock
13	7046159	1	SPRING, Lever
14	7012068	2	RING, Rear Lift Arm (Blue)
15	7031855	1	GUIDE, Belt
16	7046163	2	SPRING, Assist
17	7031838	1	BRACE, Top
18	7016122	1	ROD, Leveling (15.3" L, 3/4-24 thread)
19	7090361	1	SCREW, 5/16-18 x 5/8" Hex Washer Self-Tap
20	7058969	1	ASSEMBLY, Clutch Plate
21	7036430	1	RAIL, Deck Lift, Right Hand -(Was 7043848)
22	7073269	1	RAIL, Deck Lift, Left Hand
23	7046157	1	DETENT, Height Adjust
24	7090324	2	SCREW, 3/8-16 x 1" Hex Washer Self-Tap
25	7046217	1	SPACER, Detent
26	7091198	3	SCREW, 3/8-16 x 5/8" Hex Washer Self-Tap
27	7026420	1	GRIP, Height Adjustment Lever
28	7012067	2	RING, Front Lift Arm (Red)
29	7032997	1	ARM, Front Lift
30	7058041	1	WELDMENT, Front Lift Arm
31	7091598	1	PIN, 1/8 x 3/4" Cotter -(Was 7090365)
32	7022717	1	ROD, Deck Support (Front Lift Arm to Front End)
33	7017847	1	RING, .438 External Retaining
34	7090858	2	SCREW, 5/16-18 x 1/2" Hex Washer Self-Tap
35	7071920	2	SPACER, Deck Lift
36	7092051	1	BOLT, #10-24 x 1" Flat Head Square Neck
37	7091290	1	NUT, #10-24 Hex Nyloc
38	7032243	1	ANCHOR
39	7090233	2	SCREW, 5/16-24 x 3/4" Hex Head Cap, GR 5
40	7090391	2	WASHER, 5/16" Internal Tooth Lock

SPINDLE

Note: Unless noted otherwise, use the standard torque specifications

Mfg. No: 7800107

1 ASSEMBLY

NOTE: Spindle housing assembly, Part no. 7050696 includes items 4 and 5.

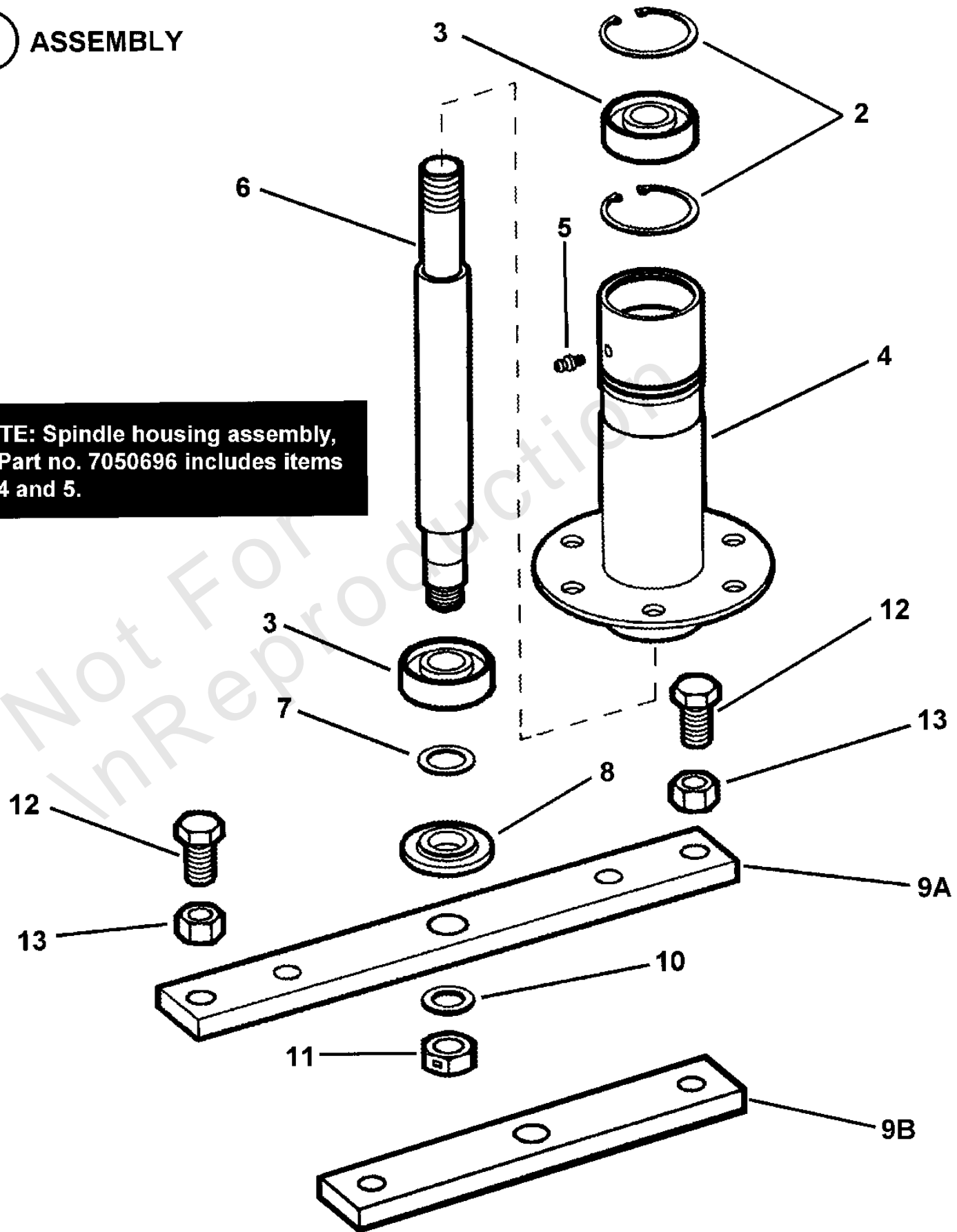

SPINDLE

REF NO	PART NO	QTY	DESCRIPTION
1	7054531	1	ASSEMBLY, Spindle Housing (Incl. items 2 thru 9A & 10 thru 13) -(used on 33" deck)
1	7058049	1	ASSEMBLY, Spindle Housing (Incl. items 2 thru 8 & 9B thru 11) -(used on 28" decks)
2	7012491	2	RING, 1.85" Internal Retaining
3	7013313	2	BEARING, Spindle
4	7050696	1	WELDMENT, Spindle Housing (includes 7010817 fitting)
5	7010817	1	LUBE FITTING, 3/16" Press-In
6	7044785	1	SPINDLE, Rider (10.327" overall length)
7	7010935	1	WASHER, .77 x 1.13 x .06 Flat
8	7014407	1	WASHER, Spindle
9A	7037751	1	HOLDER, Blade -(used on 33" deck)
9B	7031184	1	HOLDER, Blade -(used on 28" decks)
10	7044782	1	SPACER, Blade Centering
11	7090356	1	NUT, 5/8-18 Hex Center Lock Jam
12	7090491	2	SCREW, 1/2-20 x 1-1/4" Hex Head Cap, GR 5
13	7091939	2	NUT, 1/2-20 Hex, GR 5 or B

WHEELS, FRONT & REAR

Note: Unless noted otherwise, use the standard torque specifications

Mfg. No: 7800107

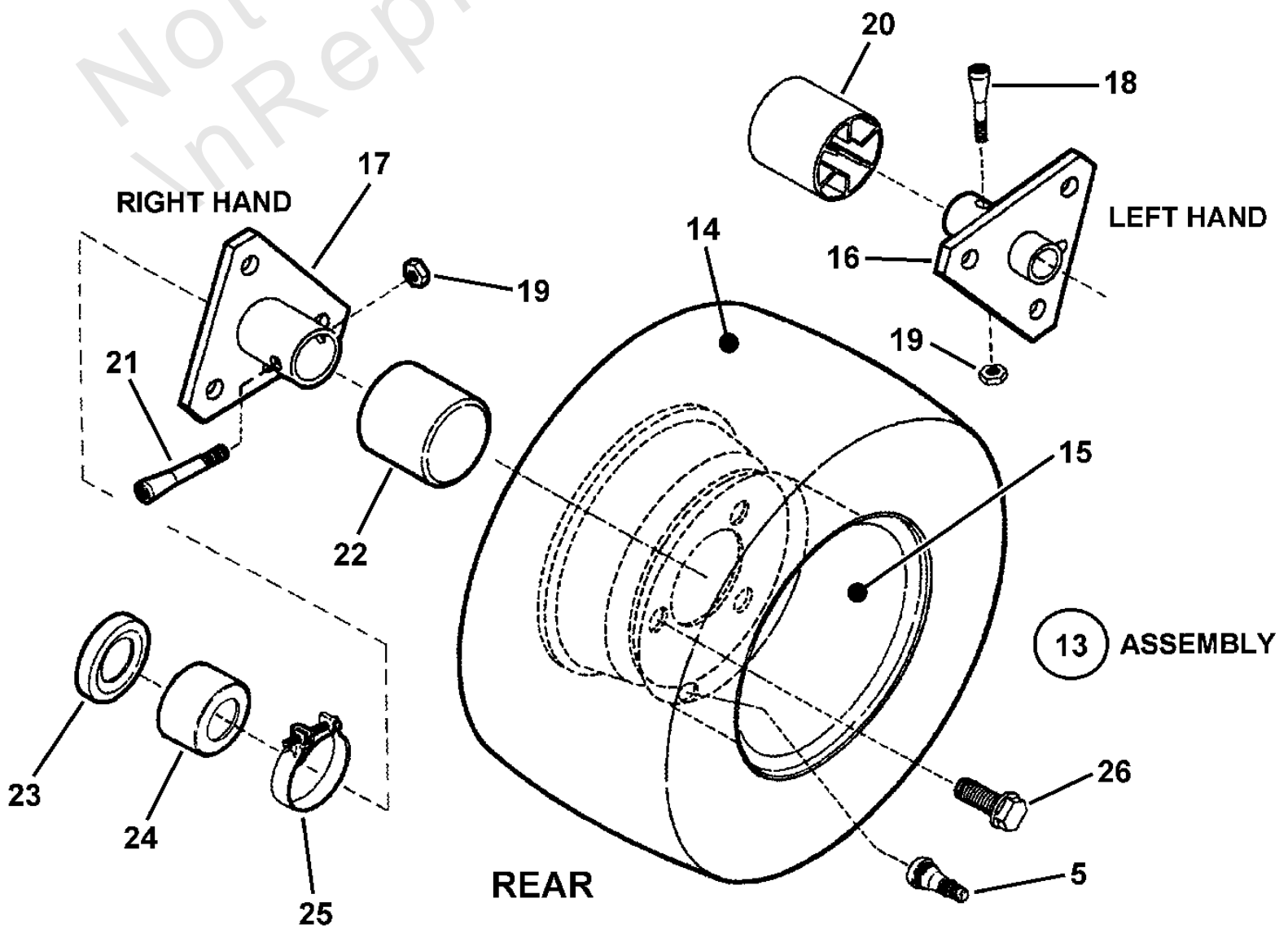
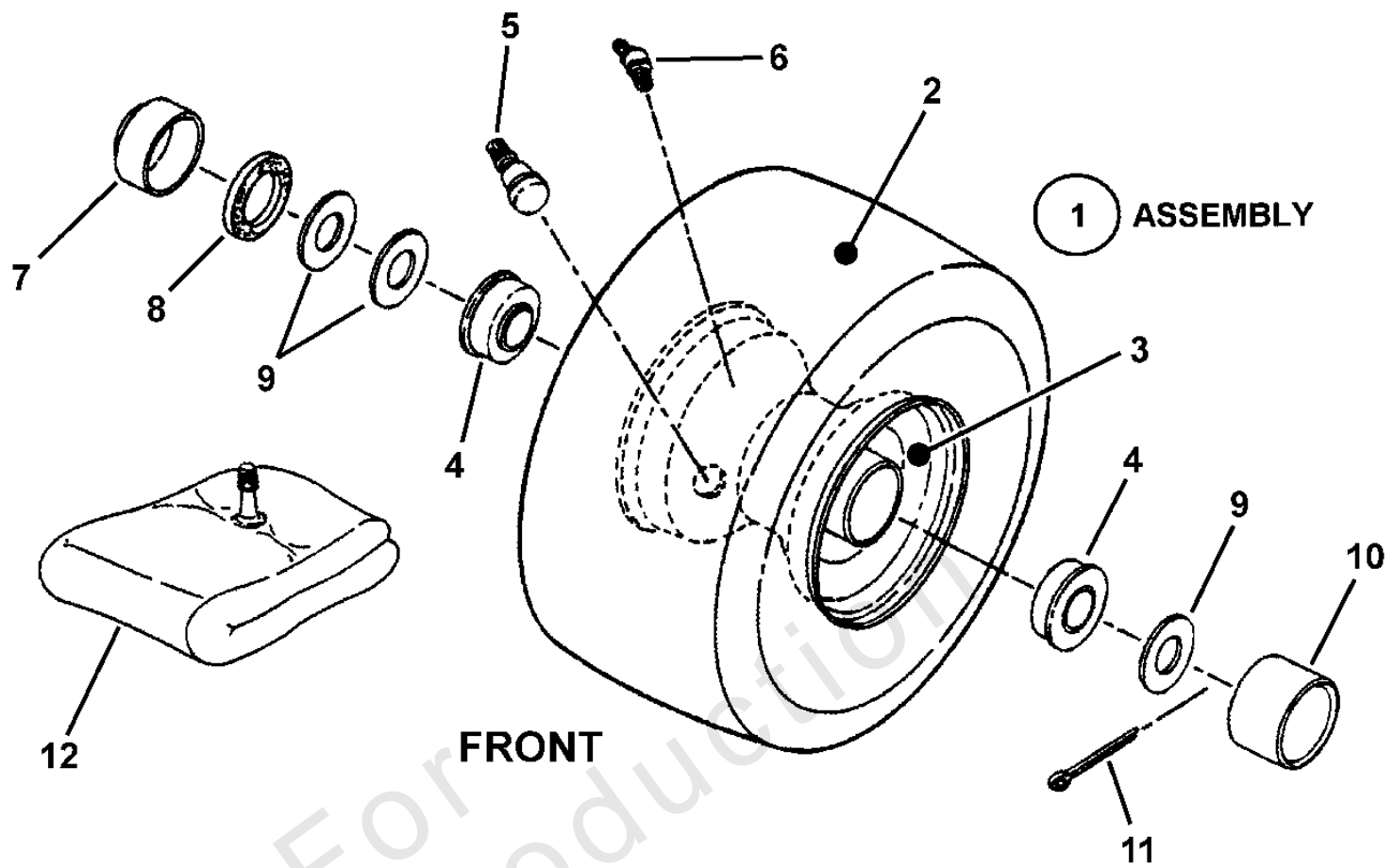

WHEELS, FRONT & REAR

REF NO	PART NO	QTY	DESCRIPTION
1	7058943	2	ASSEMBLY, Front Tire & Rim (Complete) -(Includes Items 2, 3, 4, 5 & 6)
2	7073563	1	TIRE, 11 x 4.00-4 (Kenda)
3	7017146	1	RIM (For 4.10/3.50 x 4 Tire)
4	7011807	2	BALL BEARING, Flange (3/4" I.D.)
5	7012234	1	VALVE STEM, Snap In
6	7014669	1	* LUBE Fitting, Straight (for 3/16" hole)
6	7076998	1	* LUBE Fitting, Straight (for 1/4" hole)
6	7010909	1	* LUBE Fitting, 90 Degree, Ball Check (for 1/4" hole)
6	7104428	1	* LUBE Fitting, 90 Degree, Ball Check (for 5/16" hole)
7	7031038	1	CAP, Dust
8	7011032	1	FELT SEAL
9	7010935	3	WASHER, .77 x 1.13 x .06 Flat
10	7011022	1	HUB CAP
11	7091516	1	COTTER PIN, 5/32 x 1"
12	7010821	1	TUBE, Inner (For 4.10/3.50 x 4 Tire)
13	7058951	2	ASSEMBLY, Rear Tire & Rim (28" & 33" Models) -(Includes Items 5, 14 & 15)
14	7073584	1	TIRE, 16-6.50 x 8
15	7012163	1	RIM, Extra Wide (For 16/7.50 x 8 Tire) (33" Models) -was 7017147
16	7040434	1	HUB, Rear Wheel LH, 3 Hole 3/4" ID
17	7040433	1	HUB, Rear Wheel RH, 3 Hole 1" ID
18	7011035	1	AXLE BOLT, Left Hand (5/16-24 x 1-5/8" Tapered)
19	7092062	1	NUT, Wheel Bolt, 5/16-24 Hex Center Lock -was 7011201
20	7023522	1	CAP, Hub, L. H. (Long Axle)
21	7011013	1	WHEEL BOLT, Right Hand (5/16-24 x 2" Tapered)
22	7023895	1	CAP, Hub
23	7011817	1	SEAL, 1.22" ID x 1.875" OD -CAP, Seal 1.0" ID x 1.67" OD
24	7031732	1	CAP, Seal 1.0" ID x 1.67" OD, Right Hand -(8 & 10 HP)
25	7012332	1	CLAMP, Right Hand 2" -(used on 8, 10, 11.5, 12.5, 13 & 17 HP)
25	7014542	1	CLAMP, Right Hand 2.69" -(used on 12, 14 & 15 HP)
26	7091502	3	BOLT, 1/2-20 x 3/4" Lug, GR 5

Footnotes:

NOTE* Different size holes used, measure hole for proper fit.

WIRING SCHEMATIC (13.5, 15, 16, 17 & 17.5HP Briggs Engines)

Note: Unless noted otherwise, use the standard torque specifications

Mfg. No: 7800107

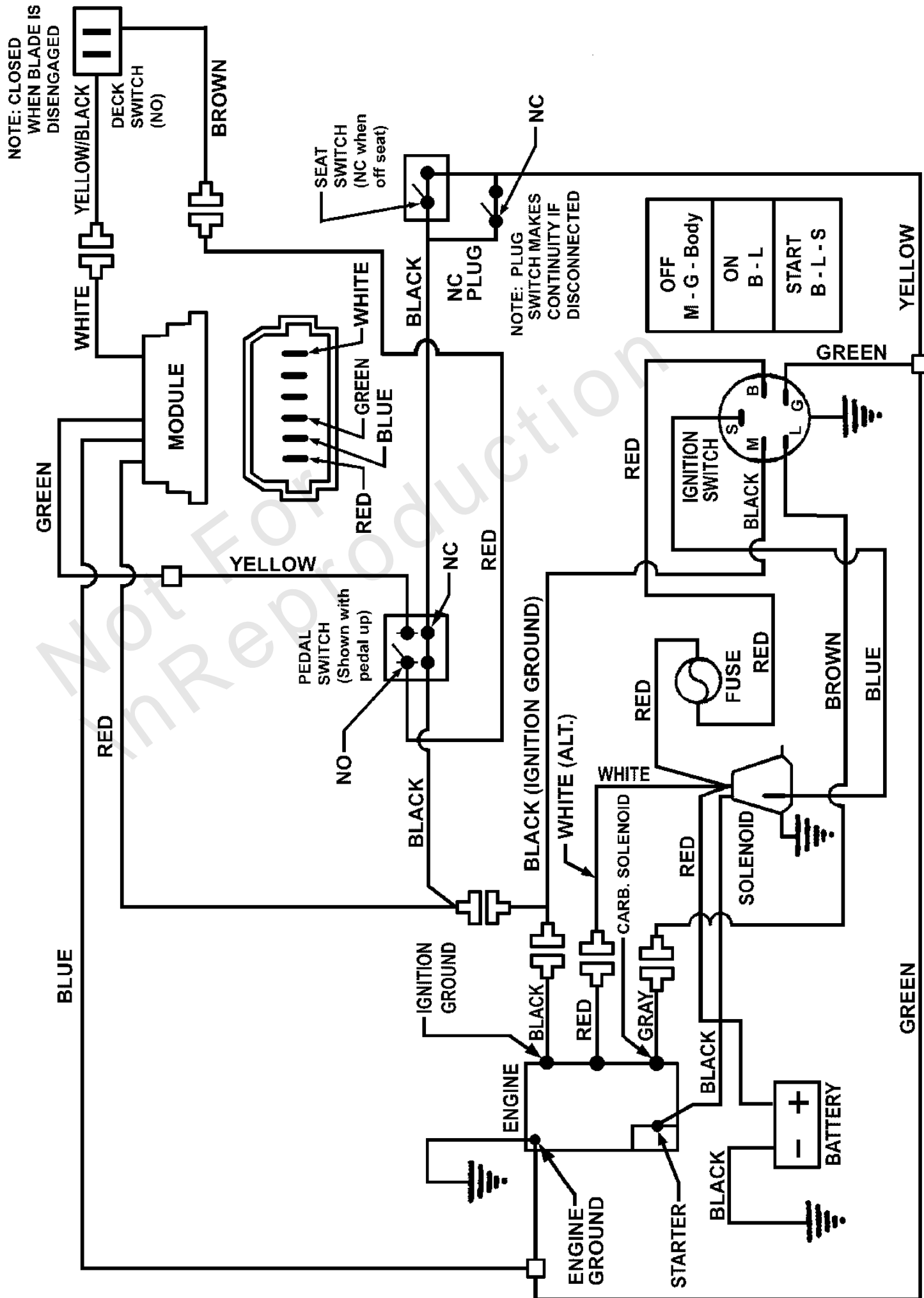

WIRING SCHEMATIC for 13.5, 15, 17 & 17.5 HP (Briggs Engine)

WIRING SCHEMATIC (13.5, 15, 16, 17 & 17.5HP Briggs Engines)

REF NO	PART NO	QTY	DESCRIPTION
	-----		Wiring Schematic incl. harness #'s 7022788, 7074406, 7028675 & 7015430

Not For In Reproduction

YOKE LIFT COMPONENTS

Note: Unless noted otherwise, use the standard torque specifications

Mfg. No: 7800107

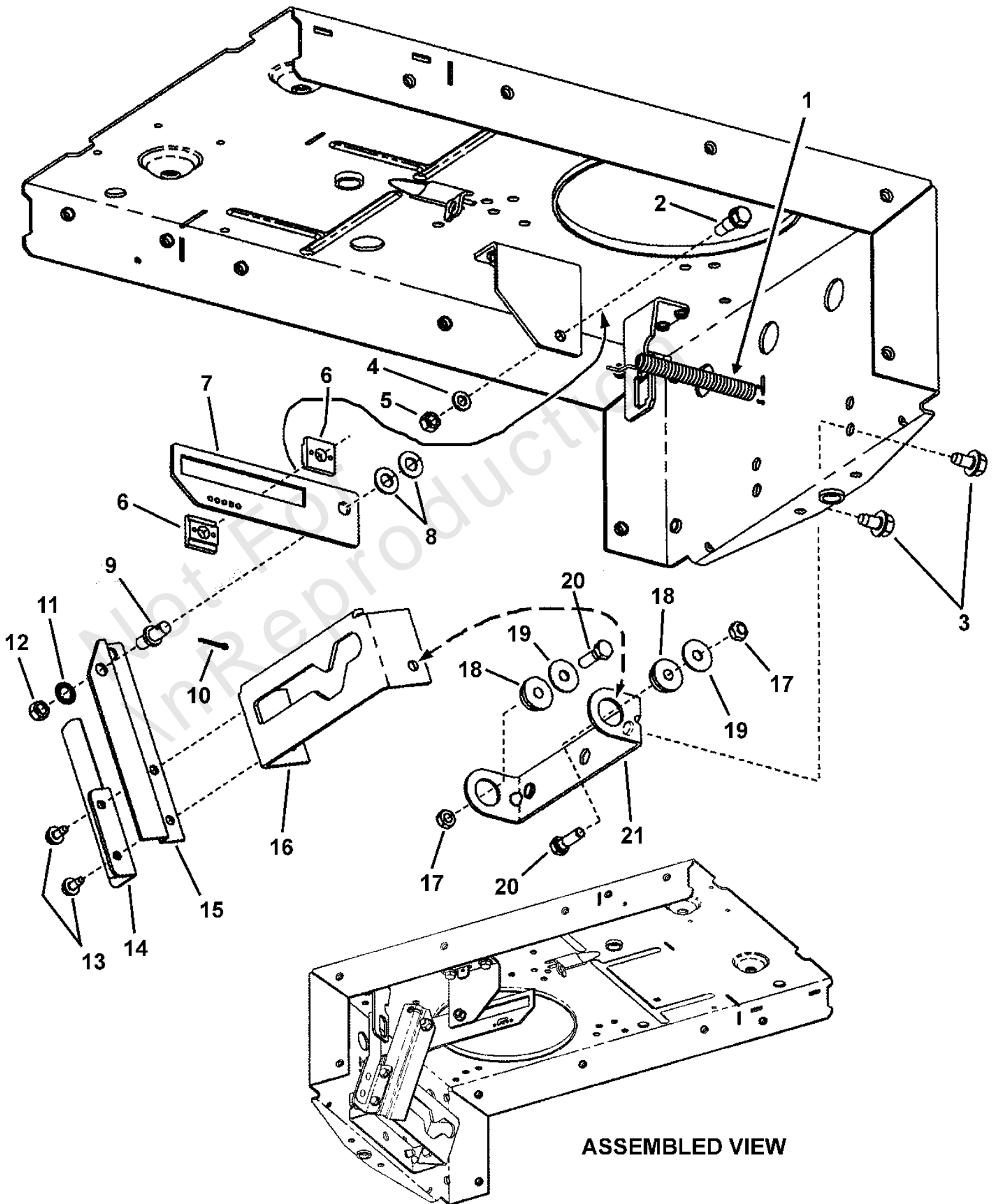

ASSEMBLED VIEW

YOKE LIFT COMPONENTS

REF NO	PART NO	QTY	DESCRIPTION
1	7013885	1	SPRING, Clutch & Brake
2	7014664	1	BOLT, 5/16-18 Shoulder
3	7091198	2	SCREW, 3/8-16 x 5/8" Hex Washer Self-Tap
4	7090187	1	WASHER, 5/16" Split Lock
5	7091511	1	NUT, 5/16-18 Hex, GR 5 or B -(Was 7090196)
6	7014663	2	SLIDE HALF
7	7047190	1	BRACKET, Slide
8	7090122	2	WASHER, 3/8" Flat SAE
9	7015464	1	STUD, Clutch Link (3/8-24 thread)
10	7091597	1	PIN, 3/32 x 3/4" Cotter -(Was 7090037)
11	7090390	1	WASHER, 3/8" Internal Tooth Lock
12	7091630	1	NUT, 3/8-24 Hex, GR 5 or B -(Was 7090155)
13	7091122	2	SCREW, 1/4-20 x 1/2" Hex Washer Self-Tap -(Was 7090539)
14	7059068	1	ASSEMBLY, Leaf Spring
15	7073733	1	ARM, Yoke
16	7046162	1	LIFT, Yoke
17	7092062	2	NUT, 5/16-24 Hex Center Lock -(Was 7011201)
18	7011048	2	BEARING, Yoke
19	7011763	2	FENDER WASHER, 5/16"
20	7090238	2	SCREW, 5/16-24 x 1" Hex Head Cap, GR 5
21	7033291	1	COLLAR, Yoke

Hardware Identification & Torque Specifications

Torque Specification Chart								
FOR STANDARD METRIC MACHINE HARDWARE (Tolerance ± 20%)								
Property Class	5.6		8.8		10.9		12.9	
	Class 5.6		Class 8.8		Class 10.9		Class 12.9	
Size Of Hardware	in/lbs	Nm.	in/lbs	Nm.	in/lbs	Nm.	in/lbs	Nm.
	ft/lbs		ft/lbs		ft/lbs		ft/lbs	
M3	5.88	.56	13.44	1.28	19.2	1.80	22.92	2.15
M4	13.44	1.28	30.72	2.90	43.44	4.10	52.56	4.95
M5	26.4	2.50	60.96	5.75	5.97	8.10	7.15	9.7
M6	44.64	4.3	7.3	9.9	10.3	14	12.1	16.5
M7	5.2	7.1	12.1	16.5	16.9	23	19.9	27
M8	7.7	10.5	17.7	24	25	34	29	40
M10	15	21	35	48	50	67	59	81
M12	26	36	61	83	86.2	117	103	140
M14	42	58	101	132	136	185	162	220
M16	64	88	147	200	210	285	250	340
M18	89	121	202	275	287	390	346	470
M20	126	171	290	390	405	550	486	660
M22	169	230	390	530	559	745	656	890
M24	217	295	497	375	708	960	840	1140
M27	320	435	733	995	1032	1400	1239	1680
M30	435	590	995	1350	1401	1900	1681	2280
M33	590	800	1349	1830	1902	2580	2278	3090
M36	759	1030	1740	2360	2441	3310	2935	3980
M39	988	1340	2249	3050	3163	4290	3798	5150

Torque Specification Chart						
FOR STANDARD MACHINE HARDWARE (Tolerance ± 20%)						
Hardware Grade	No Marks		SAE Grade 5		SAE Grade 8	
	SAE Grade 2		SAE Grade 5		SAE Grade 8	
Size Of Hardware	in/lbs	Nm.	in/lbs	Nm.	in/lbs	Nm.
	ft/lbs		ft/lbs		ft/lbs	
8-32	19	2.1	30	3.4	41	4.6
8-36	20	2.3	31	3.5	43	4.9
10-24	27	3.1	43	4.9	60	6.8
10-32	31	3.5	49	5.5	68	7.7
1/4-20	66	7.6	8	10.9	12	16.3
1/4-28	76	8.6	10	13.6	14	19.0
5/16-18	11	15.0	17	23.1	25	34.0
5/16-24	12	16.3	19	25.8	29	34.0
3/8-16	20	27.2	30	40.8	45	61.2
3/8-24	23	31.3	35	47.6	50	68.0
7/16-14	30	40.8	50	68.0	70	95.2
7/16-20	35	47.6	55	74.8	80	108.8
1/2-13	50	68.0	75	102.0	110	149.6
1/2-20	55	74.8	90	122.4	120	163.2
9/16-12	65	88.4	110	149.6	150	204.0
9/16-18	75	102.0	120	163.2	170	231.2
5/8-11	90	122.4	150	204.0	220	299.2
5/8-18	100	136	180	244.8	240	326.4
3/4-10	160	217.6	260	353.6	386	525.0
3/4-16	180	244.8	300	408.0	420	571.2
7/8-9	140	190.4	400	544.0	600	816.0
7/8-14	155	210.8	440	598.4	660	897.6
1-8	220	299.2	580	788.8	900	1,244.0
1-12	240	326.4	640	870.4	1,000	1,360.0

The guides and ruler furnished below are designed to help you select the appropriate hardware.



Nut, M8

Thread Diameter (mm)

Inside Diameter (in) Threads per inch

Nut, 1/2-16



Screw, M8- 1.25 x 25

Thread Diameter (mm) Distance between threads (mm) Body Length (mm)

Body Diameter Threads per inch Body Length (in)

Screw, 1/2- 16 x 2



Standard Hardware Sizing

When a washer or nut is identified as 1/2" (M8), this is the *Nominal size*, meaning the *inside diameter* is 1/2 inch (8mm metric thread diameter); if a second number is present it represents the *threads per inch* (distance between threads).

When bolt or capscrew is identified as 1/2 - 16 x 2" (M8 - 1.25 x 50), this means the *Nominal size*, or body diameter is 1/2 inch (8mm metric thread diameter), the second number, 16, represents the *threads per inch*, (*distance between threads*). The final number is the body length of the bolt or screw, 2 inches (50mm).

NOTES

- These torque values are to be used for all hardware excluding: locknuts, self-tapping screws, thread forming screws, sheet metal screws and socket head setscrews.
- Recommended seating torque values for locknuts:
 - for prevailing torque locknuts - use 65% of grade 5 torques.
 - for flange whizlock nuts and screws - use 135% of grade 5 torques.
- Unless otherwise noted on assembly drawings, all torque values must meet this specification.

Common Hardware Types

Hex Head Capscrew



Washer



Carriage Bolt



Hex Nut

Wrench & Fastener Size Guide

1/4" Bolt or Nut Wrench—7/16"	5/16" Bolt or Nut Wrench—1/2"	3/8" Bolt or Nut Wrench—9/16"	7/16" Bolt or Nut Wrench (Bolt)—5/8" Wrench (Nut)—11/16"	1/2" Bolt or Nut Wrench—3/4"
M6 Bolt or Nut Wrench—10mm	M8 Bolt or Nut Wrench—13mm	M10 Bolt or Nut Wrench—17mm	M12 Bolt or Nut Wrench—19mm	M14 Bolt or Nut Wrench—22mm

