

Parts Manual

Mfg. No: 7600192
Grass Catcher, Twin

Model Components	Page
Twin Catcher.....	4
Torque Specification Chart.....	6

Not For
Reproduction

Twin Catcher

Note: Unless noted otherwise, use the standard torque specifications

Mfg. No: 7600192

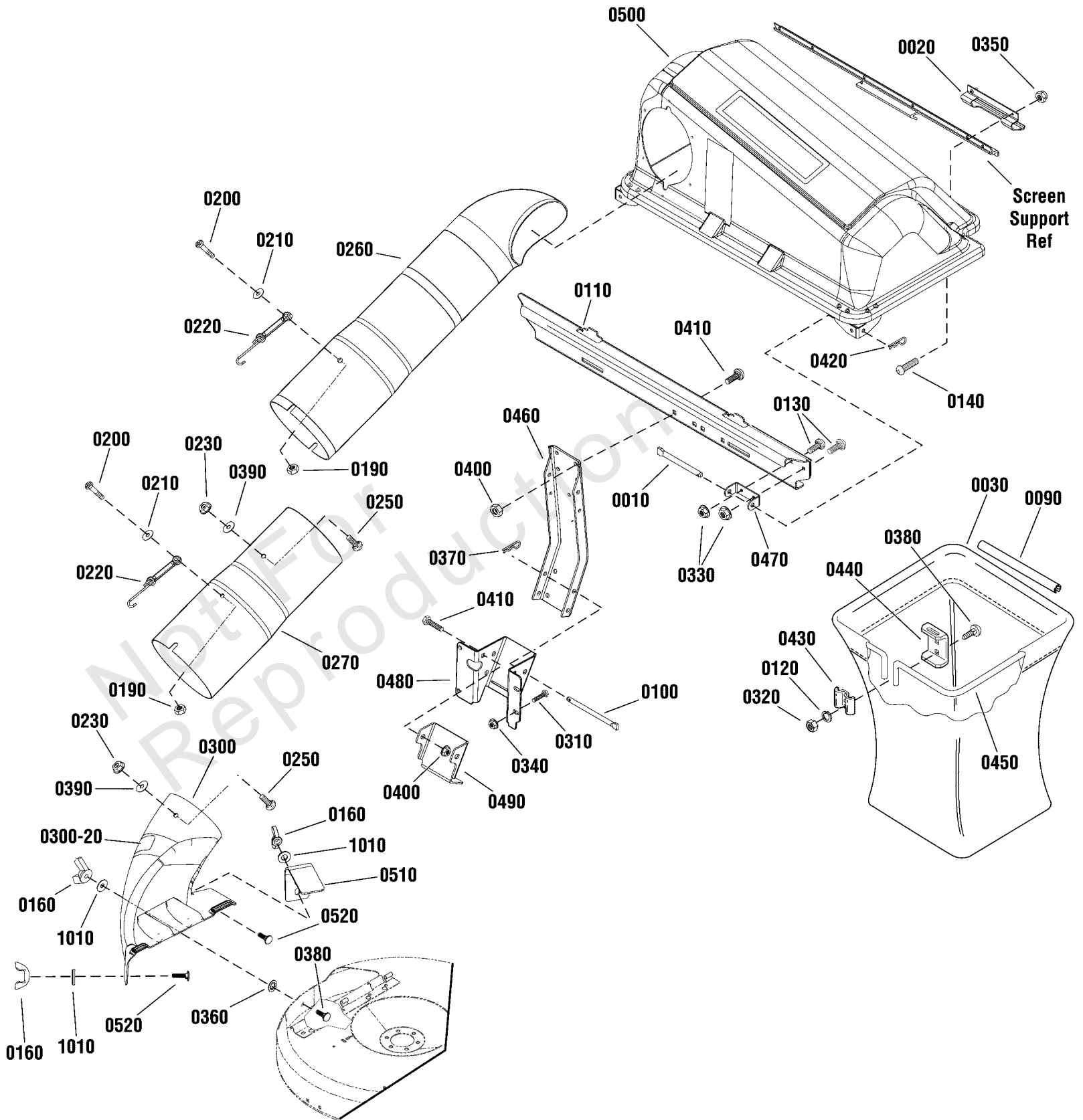

Twin Catcher

REF NO	PART NO	QTY	DESCRIPTION
0010	720525	2	PIN, Cover Hinge
0020	720537	1	HANDLE
0030	1703764SM	2	BAG, Grass
0090	1733709SM	2	EDGING
0100	1734229SM	2	PIN, Hinge
0110	1736026SM	1	CROSS SUPPORT
0120	1917356SM	4	LOCKWASHER, Spring
0130	1960252SM	4	BOLT, Round Head Short Neck, 1/4-20 x 5/8
0140	1960404SM	2	SCREW, Truss Head, 10-24 x 3/4
0160	7024085YP	1	WINGNUT, 5/16
0190	7036404SM	2	NUT, Weld
0200	7036415SM	2	SCREW, Phillips Head, 5/8
0210	7036422SM	2	WASHER, Flat
0220	7036433SM	2	STRAP, Mounting
0230	7036543SM	2	NUT, Tee
0250	7091833SM	2	SCREW, Phillips, 5/16 x 5/8
0260	7100618YP	1	TUBE, Upper
0270	7100701YP	1	TUBE, Lower
0300	7503112YP	1	DECK ADAPTER ASSEMBLY -(Incl. Ref. Nos. 0300-20)
0300-20	7046720SM	1	DECAL, Danger
0310	1921332SM	3	CAPSCREW, Hex Head, 5/16-18 X 3/4
0320	703465	4	NUT, 5/16-18
0330	703233	4	NUT, Flange, 1/4-20
0340	703409	3	NUT, 5/16-18, Serrated Lock Flange, GR5
0350	703412	2	NUT, Ny-Lock, 10-24
0360	703297	1	RETAINER, 5/16 x 5/8
0370	703300	2	PIN, Hair, 3/32
0380	703185	5	BOLT, Carriage, 5/16-18 X 3/4
0390	703350	2	WASHER, Flat, 5/16
0400	703793	6	NUT, Whiz Lock, 3/8-16
0410	703815	6	BOLT, Carriage, Short Neck, 3/8-16 x 1
0420	703796	2	PIN, Hair
0430	1672023ASM	2	CLAMP
0440	1703807ASM	2	HANGER, Grass Bag
0450	1733491ASM	2	HOOP, Twin Catcher
0460	1734223ASM	1	SUPPORT, Upright
0470	1736886BMYP	2	PIVOT, Hinge
0480	7301294BMYP	1	BRACKET, Catcher
0490	7301377BMYP	1	BRACKET, Catcher Support
0500	7106054YP	1	COVER ASSEMBLY
0510	7301385BMYP	1	BRACKET, Mounting
0520	703800	2	BOLT, Carriage, 5/16-18 x 1
1010	703298	3	WASHER, Flat

Hardware Identification & Torque Specifications

Torque Specification Chart								
FOR STANDARD METRIC MACHINE HARDWARE (Tolerance ± 20%)								
Property Class	5.6		8.8		10.9		12.9	
	Class 5.6		Class 8.8		Class 10.9		Class 12.9	
Size Of Hardware	in/lbs	Nm.	in/lbs	Nm.	in/lbs	Nm.	in/lbs	Nm.
	ft/lbs		ft/lbs		ft/lbs		ft/lbs	
M3	5.88	.56	13.44	1.28	19.2	1.80	22.92	2.15
M4	13.44	1.28	30.72	2.90	43.44	4.10	52.56	4.95
M5	26.4	2.50	60.96	5.75	5.97	8.10	7.15	9.7
M6	44.64	4.3	7.3	9.9	10.3	14	12.1	16.5
M7	5.2	7.1	12.1	16.5	16.9	23	19.9	27
M8	7.7	10.5	17.7	24	25	34	29	40
M10	15	21	35	48	50	67	59	81
M12	26	36	61	83	86.2	117	103	140
M14	42	58	101	132	136	185	162	220
M16	64	88	147	200	210	285	250	340
M18	89	121	202	275	287	390	346	470
M20	126	171	290	390	405	550	486	660
M22	169	230	390	530	559	745	656	890
M24	217	295	497	375	708	960	840	1140
M27	320	435	733	995	1032	1400	1239	1680
M30	435	590	995	1350	1401	1900	1681	2280
M33	590	800	1349	1830	1902	2580	2278	3090
M36	759	1030	1740	2360	2441	3310	2935	3980
M39	988	1340	2249	3050	3163	4290	3798	5150

Torque Specification Chart						
FOR STANDARD MACHINE HARDWARE (Tolerance ± 20%)						
Hardware Grade	No Marks		SAE Grade 5		SAE Grade 8	
	SAE Grade 2		SAE Grade 5		SAE Grade 8	
Size Of Hardware	in/lbs	Nm.	in/lbs	Nm.	in/lbs	Nm.
	ft/lbs		ft/lbs		ft/lbs	
8-32	19	2.1	30	3.4	41	4.6
8-36	20	2.3	31	3.5	43	4.9
10-24	27	3.1	43	4.9	60	6.8
10-32	31	3.5	49	5.5	68	7.7
1/4-20	66	7.6	8	10.9	12	16.3
1/4-28	76	8.6	10	13.6	14	19.0
5/16-18	11	15.0	17	23.1	25	34.0
5/16-24	12	16.3	19	25.8	29	34.0
3/8-16	20	27.2	30	40.8	45	61.2
3/8-24	23	31.3	35	47.6	50	68.0
7/16-14	30	40.8	50	68.0	70	95.2
7/16-20	35	47.6	55	74.8	80	108.8
1/2-13	50	68.0	75	102.0	110	149.6
1/2-20	55	74.8	90	122.4	120	163.2
9/16-12	65	88.4	110	149.6	150	204.0
9/16-18	75	102.0	120	163.2	170	231.2
5/8-11	90	122.4	150	204.0	220	299.2
5/8-18	100	136	180	244.8	240	326.4
3/4-10	160	217.6	260	353.6	386	525.0
3/4-16	180	244.8	300	408.0	420	571.2
7/8-9	140	190.4	400	544.0	600	816.0
7/8-14	155	210.8	440	598.4	660	897.6
1-8	220	299.2	580	788.8	900	1,244.0
1-12	240	326.4	640	870.4	1,000	1,360.0

The guides and ruler furnished below are designed to help you select the appropriate hardware.



Nut, M8

Thread Diameter (mm)

Inside Diameter (in) Threads per inch

Nut, 1/2-16



Screw, M8- 1.25 x 25

Thread Diameter (mm) Distance between threads (mm) Body Length (mm)

Body Diameter Threads per inch Body Length (in)

Screw, 1/2- 16 x 2



Standard Hardware Sizing

When a washer or nut is identified as 1/2" (M8), this is the *Nominal size*, meaning the *inside diameter* is 1/2 inch (8mm metric thread diameter); if a second number is present it represents the *threads per inch* (distance between threads).

When bolt or capscrew is identified as 1/2 - 16 x 2" (M8 - 1.25 x 50), this means the *Nominal size*, or body diameter is 1/2 inch (8mm metric thread diameter), the second number, 16, represents the *threads per inch*, (*distance between threads*). The final number is the body length of the bolt or screw, 2 inches (50mm).

NOTES

- These torque values are to be used for all hardware excluding: locknuts, self-tapping screws, thread forming screws, sheet metal screws and socket head setscrews.
- Recommended seating torque values for locknuts:
 - for prevailing torque locknuts - use 65% of grade 5 torques.
 - for flange whizlock nuts and screws - use 135% of grade 5 torques.
- Unless otherwise noted on assembly drawings, all torque values must meet this specification.

Common Hardware Types

Hex Head Capscrew



Washer



Carriage Bolt



Hex Nut

Wrench & Fastener Size Guide

1/4" Bolt or Nut Wrench—7/16"	5/16" Bolt or Nut Wrench—1/2"	3/8" Bolt or Nut Wrench—9/16"	7/16" Bolt or Nut Wrench (Bolt)—5/8" Wrench (Nut)—11/16"	1/2" Bolt or Nut Wrench—3/4"
M6 Bolt or Nut Wrench—10mm	M8 Bolt or Nut Wrench—13mm	M10 Bolt or Nut Wrench—17mm	M12 Bolt or Nut Wrench—19mm	M14 Bolt or Nut Wrench—22mm

