

Parts Manual for
SNAPPER[®]

**21" STEEL DECK WALK BEHIND
COMMERCIAL MOWERS
SERIES 20**

Model No.	Description
7800772	CP218520
7800848	CP218520
7800764	CRP218520
7800847	CRP218520

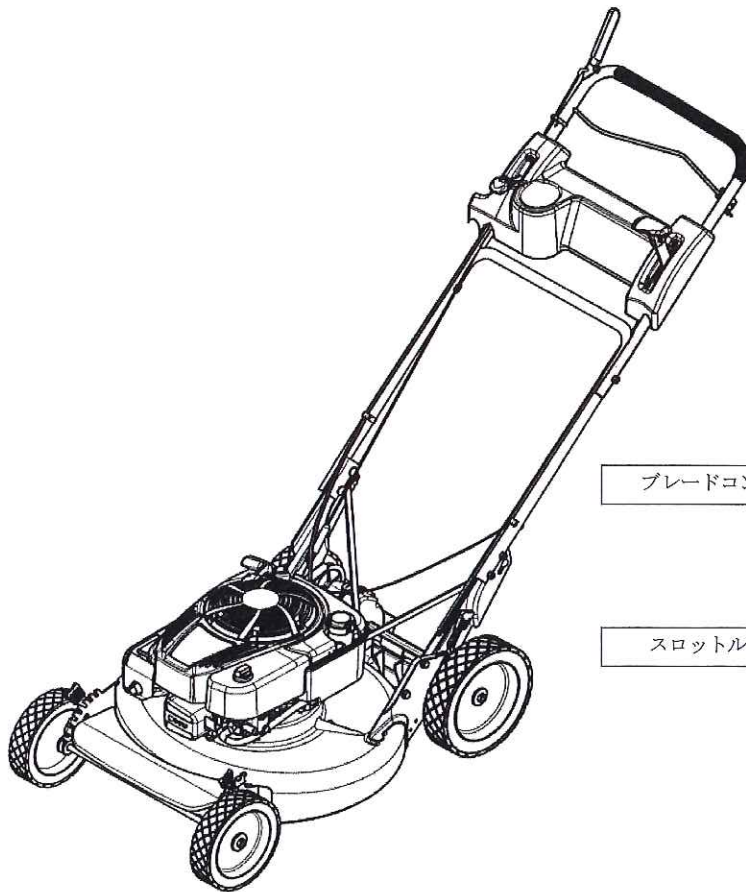

ブレードコントロールレバーがハンドル下側

スロットルレバー有り

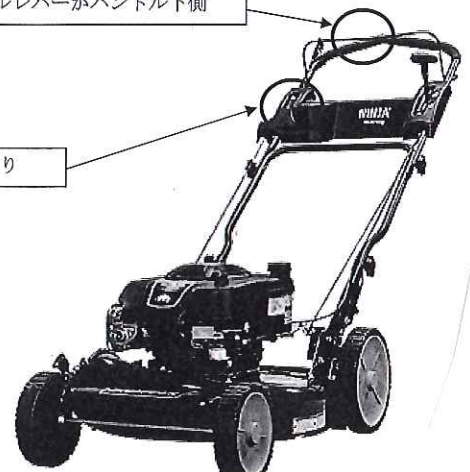

Briggs & Stratton Yard Power Products Group
535 Macon Road
McDonough, GA, 30253 U.S.A.
800-935-2967

Manual No. 7104803
Revision: B 1/19/2012

Not for
Reproduction

PAGE	GROUP
4	Handles & Controls Group
8	Engine, Deck & Blade Group
10	Wheel & Height-of-Cut Assembly Group
12	Drive System, Self-Propelled
16	Transmission - Differential Group
18	Grass Bag & Accessories Group
20	Side Chute, Adapter
22	Decals Group

Not for
Reproduction

Handles & Controls Group

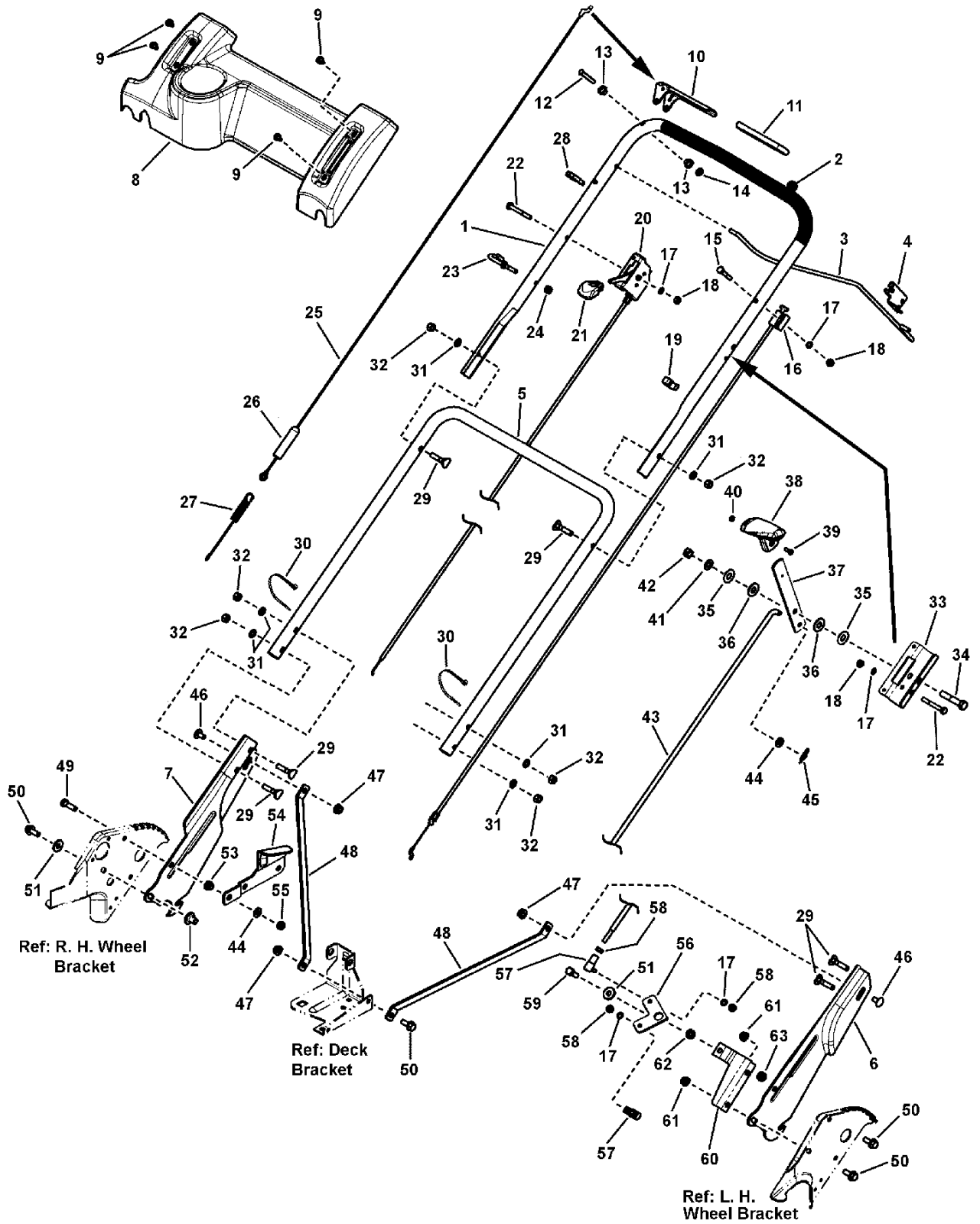

Item	Part No	Qty	Description
1	7074411A	1	HANDLE, Upper
2	7023810	1	FOAM GRIP, 18.75" long
3	7074418A	1	BAIL, OPC Control
4	7034872	1	CLIP, Zone Control
5	7074156A	1	HANDLE, Middle
6	7033985A	1	HANDLE, Lower, Adjustable, LH
7	7033986A	1	HANDLE, Lower, Adjustable, RH
8	7074140	1	CONTROL PANEL, No Electric Switch
9	7900067	4	SCREW, 1/4-20 x .550" Pan Head Self-Tap (Torx)
10	7074473A	1	HANDLE, Clutch
11	7028407	1	GRIP, International Symbol
12	7023792	1	PIN, 1/4 x 1-1/2"
13	7014343	2	BUSHING, .27 x .35 x .4 Flange
14	7091020	1	PUSH-NUT, 1/4"
15	7079577	2	SCREW, 1/4-20 x 1-1/2" Hex Head Cap GR 5
16	7102593	1	CABLE, Zone Control, W14
17	7090053	5	WASHER, 1/4" Internal Tooth Lock, YZ
18	7091576	3	NUT, 1/4-20 Hex, GR 5
19	7023813	1	CLIP, Wiring Harness
20	7102594	1	THROTTLE CONTROL, (63.12" Long)
21	7075308	1	KNOB, Throttle
22	7090505	2	SCREW, 1/4-20 x 2" Hex Head Cap, GR 5
23	7028488	1	GUIDE, Rope (1/4-20 thread)
24	7076978	1	NUT, 1/4-28 Hex GR 5 or B
25	7034604	1	CONTROL, Clutch, 21"
26	7012121	1	COVER, Vinyl
27	7012122	1	SPRING, Clutch
28	7026219	1	CLAMP, 7/8" Double Cable
29	7091190	6	BOLT, 5/16-18 X1-1/2" Curved Head Square Neck, GR 2 BZ
30	7012080	1	CABLE-TIE, 7"
31	7090391	6	WASHER, 5/16" Internal Tooth Lock
32	7091511	6	NUT, 5/16-18 Hex, GR 5 or B, BZ (Was 7091069)
33	7074003	1	BRACKET, Shift
34	7091305	1	SCREW, 3/8-16 x 2" Hex Head Cap, GR 5
35	7031961	2	WASHER, 7/16" Flat
36	7028465	2	WASHER, Nylon
37	7074113	1	LEVER, Shift
38	7075182	1	KNOB, Shift
39	7091167	1	SCREW, #8-32 x 1/2" Cross Recess Filister Head Machine
40	7091018	1	NUT, #8-32 Hex
41	7028568	1	WASHER, Belleville
42	7091585	2	NUT, 3/8-16 Hex Center Lock
43	7074133	1	ROD, Speed Control
44	7090188	2	WASHER, .34 x .69 x .08 Flat, YZ

Footnotes:

Handles & Controls Group

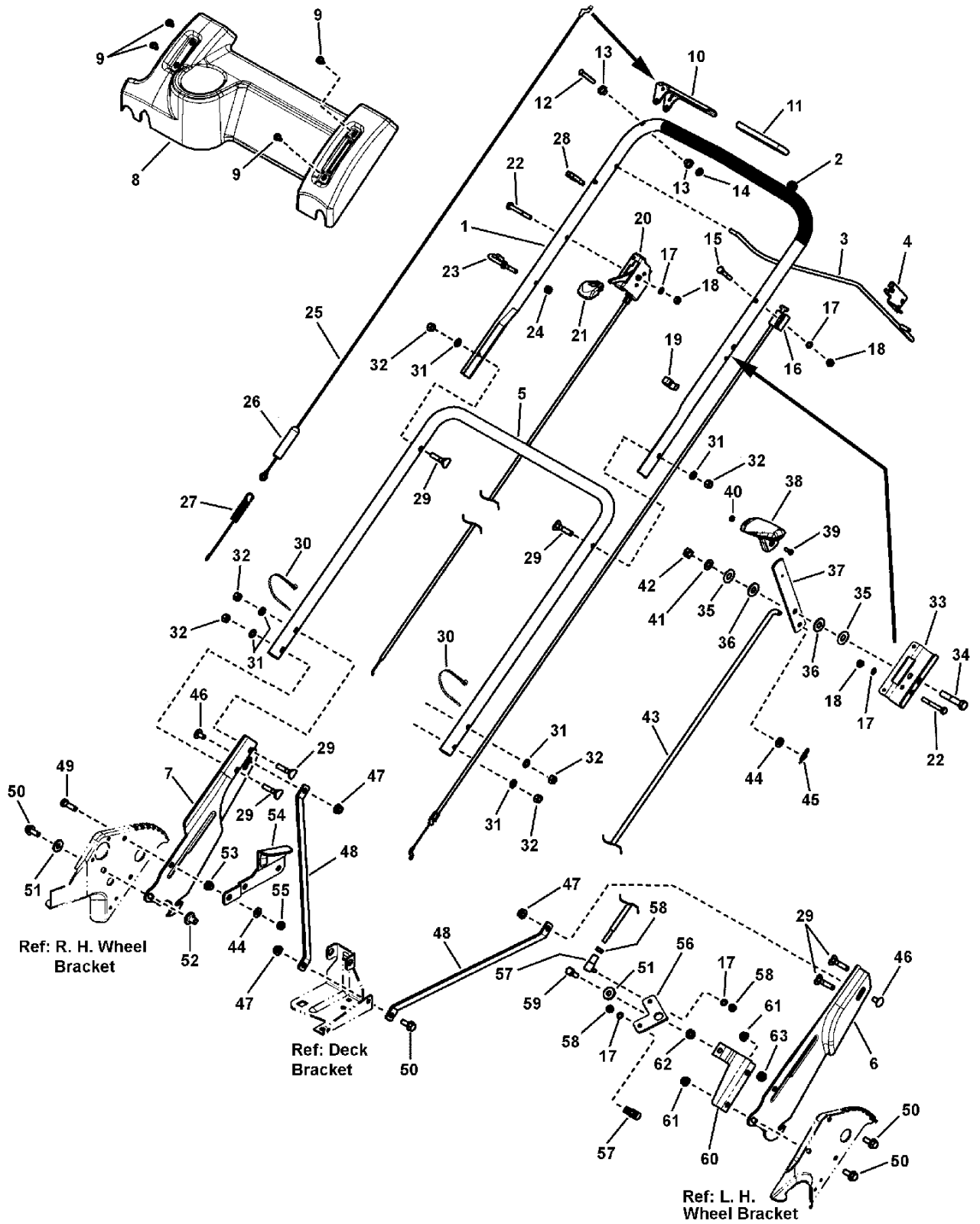

Item	Part No	Qty	Description
45	7034162	1	COTTER PIN, 5/16" Self Lock
46	7090799	2	BOLT, 5/16-18 x 5/8" Round Head Short Square Neck, GR 5 BZ (Was7091026)
47	7091601	3	NUT, 5/16-18 Hex Flange Lock, GR 5, YZ
48	7046707A	2	BRACE, Handle
49	7090238	1	SCREW, 5/16-24 x 1" Hex Head Cap, GR 5, BZ
50	7090595	4	BOLT, 5/16-18 x 3/4" Hex Flange Lock
51	7091130	2	WASHER, .327 x .875 x .09 Flat, BZ
52	7090895	1	T-NUT, 5/16-18
53	7012114	1	BUSHING, Differential
54	7034179A	1	LINK, Differential, Commercial (also part of Drive System Group)
55	7091606	1	NUT, 5/16-24 Hex Center Lock, GR B, BZ (Was 7091074)
56	7073913	1	BELL CRANK, Black Zinc
57	7015753	2	BALL JOINT
58	7090095	3	NUT, 1/4-28 Hex GR 5 or B, YZ
59	7091904	1	SCREW, 5/16-18 x 7/8" Hex Head Cap, GR 5 YZ
60	7073822A	1	BRACKET, Bell Crank
61	7090585	4	NUT, 5/16-18 Hex Flange Lock, GR 5
62	7013849	1	SPACER, .623 OD x .328 ID x .151 L
63	7091575	1	NUT, 5/16-18 Hex Center Lock

Not for
Reproduction

Footnotes:

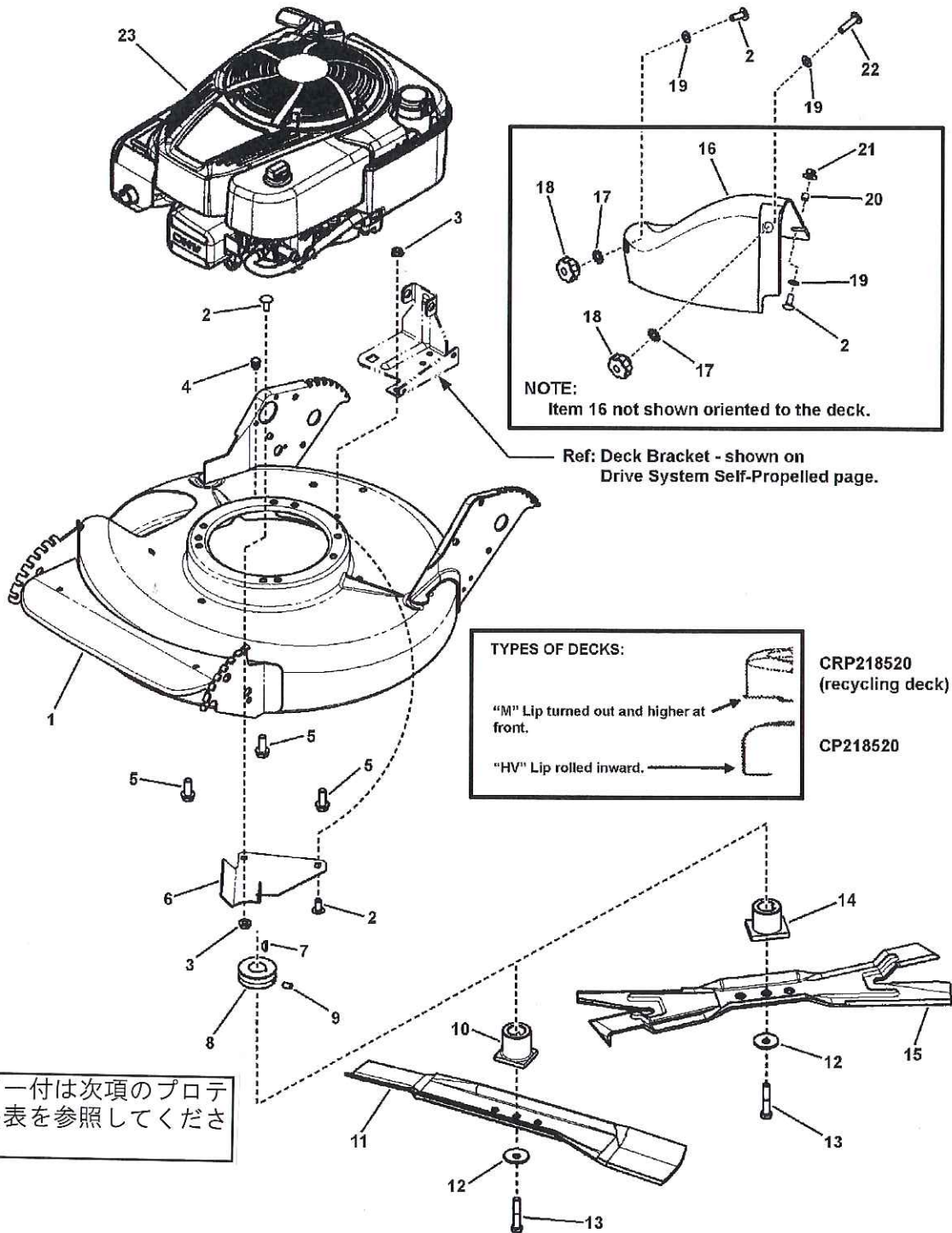

プロテクター付は次項のプロテクター部品表を参照してください。

Engine, Deck & Blade Group

Item	Part No	Qty	Description
1	7400026D	1	WELDMENT, Deck, 21" Non-Adjust. Air (used on 7800764 & 7800847 models)
1	7500549D	1	WELDMENT, Deck, 21", Self-Propelled, HV (used on 7800772 & 7800848 models)
2	7091508	3	BOLT, 5/16-18 x 3/4" Short Neck Carriage GR 5 (was 7090001)
3	7091601	2	NUT, 5/16-18 Hex Flange Lock, GR 5, YZ (was 7091070)
4	7046780	2	PLUG, Hole, Polyethylene
5	7090324	3	SCREW, 3/8-16 x 1" Self-Tapping
6	7074568	1	COVER, Belt
7	7091214	1	KEY, Woodruff #HP-506 Hi-Pro
8	7015780	1	PULLEY, Engine (25mm I. D. x 2-1/8" O.D.)
9	7092086	1	SCREW, 5/16-18 x 1/2" Hex Socket Head
10	7015626	1	HUB, Blade Drive, 25MM I.D. (.9" crank to blade, 1.75" square) (used on 7800772 & 7800848 models)
11	7026691	1	BLADE, 21" Standard Lift (used on 7800772 & 7800848 models)
12	7012063	1	WASHER, Cone
13	7090167	1	SCREW, 3/8-24 x 2" Hex Head Cap, GR 5
14	7101414	1	HUB, Blade Drive, 2 Position, 25MM I.D. (1.08" crank to blade, 1.75" x 2.25") (used on 7800764 & 7800847 models)
15	7026407	1	BLADE, 21" Ninja (used on 7800764 & 7800847 models)
16	7029149	1	COVER, 21" Deck
17	7090189	2	WASHER, 5/16" Internal/External Lock
18	7101022	2	KNOB, Fluted, 5/16-18 x 1/2"
19	7011791	3	RETAINER, 5/16" Bolt
20	7024340	1	SPACER, .316 I.D. x .375 O.D. x .310 thick
21	7090951	1	NUT, 5/16-18 Hex Large Flange Center Lock
22	7091169	1	BOLT, 5/16-18 x 1-1/8 Round Head Short Square Neck, GR 5 ZP
23	121Q72-0119-F1	1	* ENGINE, B&S 850 Series, W14
23	124Q02-0119-F1	1	* ENGINE, B&S 850 Pro Series, W14

Footnotes:

NOTE: * Purchase engine parts from engine manufacturer dealer.

クランクシャフトプロテクター部品表

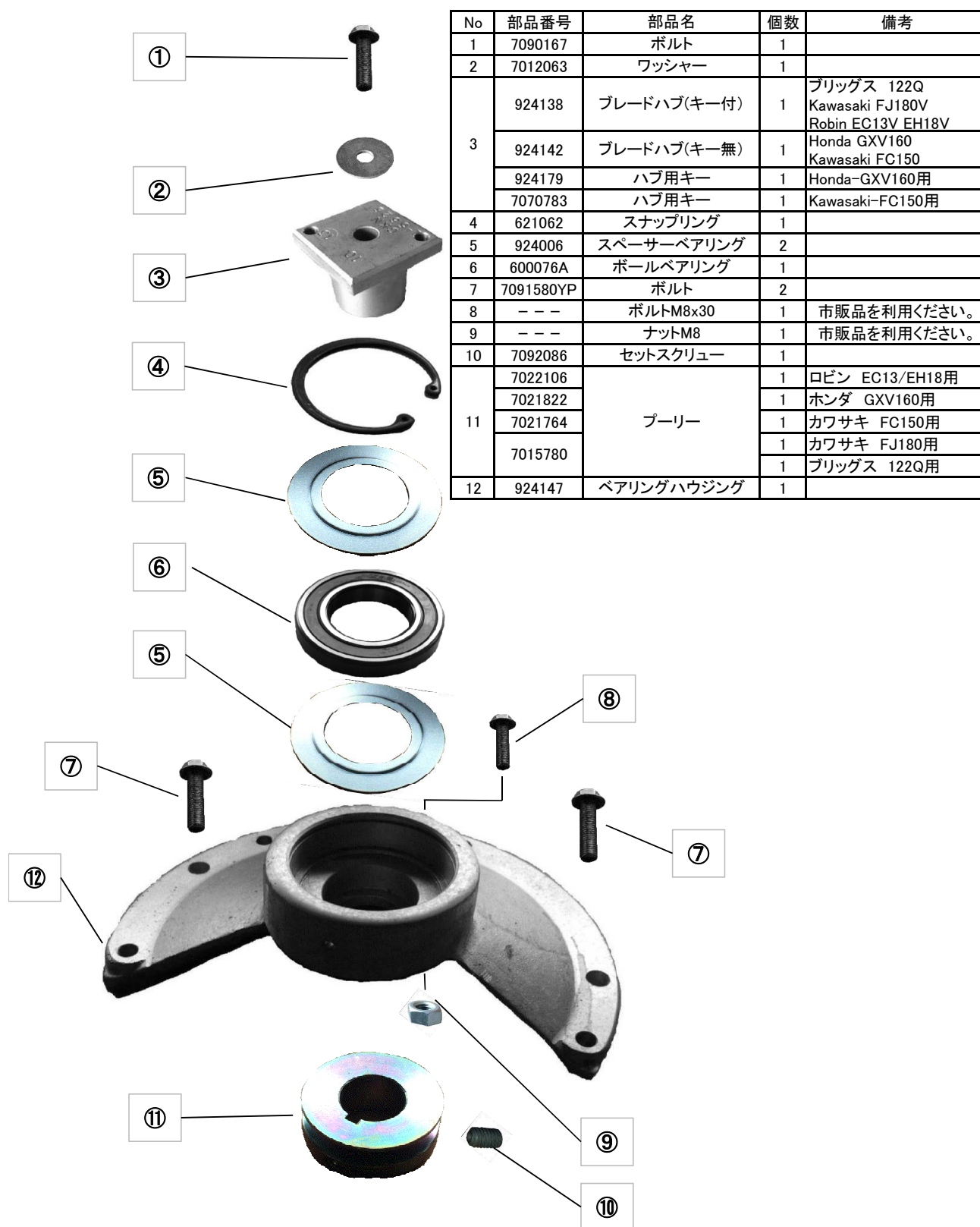

No	部品番号	部品名	個数	備考
1	7090167	ボルト	1	
2	7012063	ワッシャー	1	
3	924138	ブレードハブ(キー付)	1	ブリッグス 122Q Kawasaki FJ180V Robin EC13V EH18V
	924142	ブレードハブ(キー無)	1	Honda GXV160 Kawasaki FC150
	924179	ハブ用キー	1	Honda-GXV160用
	7070783	ハブ用キー	1	Kawasaki-FC150用
4	621062	スナップリング	1	
5	924006	スペーサーベアリング	2	
6	600076A	ボールベアリング	1	
7	7091580YP	ボルト	2	
8	---	ボルトM8x30	1	市販品を利用ください。
9	---	ナットM8	1	市販品を利用ください。
10	7092086	セットスクリュー	1	
11	7022106	プーリー	1	ロビン EC13/EH18用
	7021822		1	ホンダ GXV160用
	7021764		1	カワサキ FC150用
	7015780		1	カワサキ FJ180用
	7015780		1	ブリッグス 122Q用
12	924147	ベアリングハウジング	1	

Wheel & Height-of-Cut Assembly Group

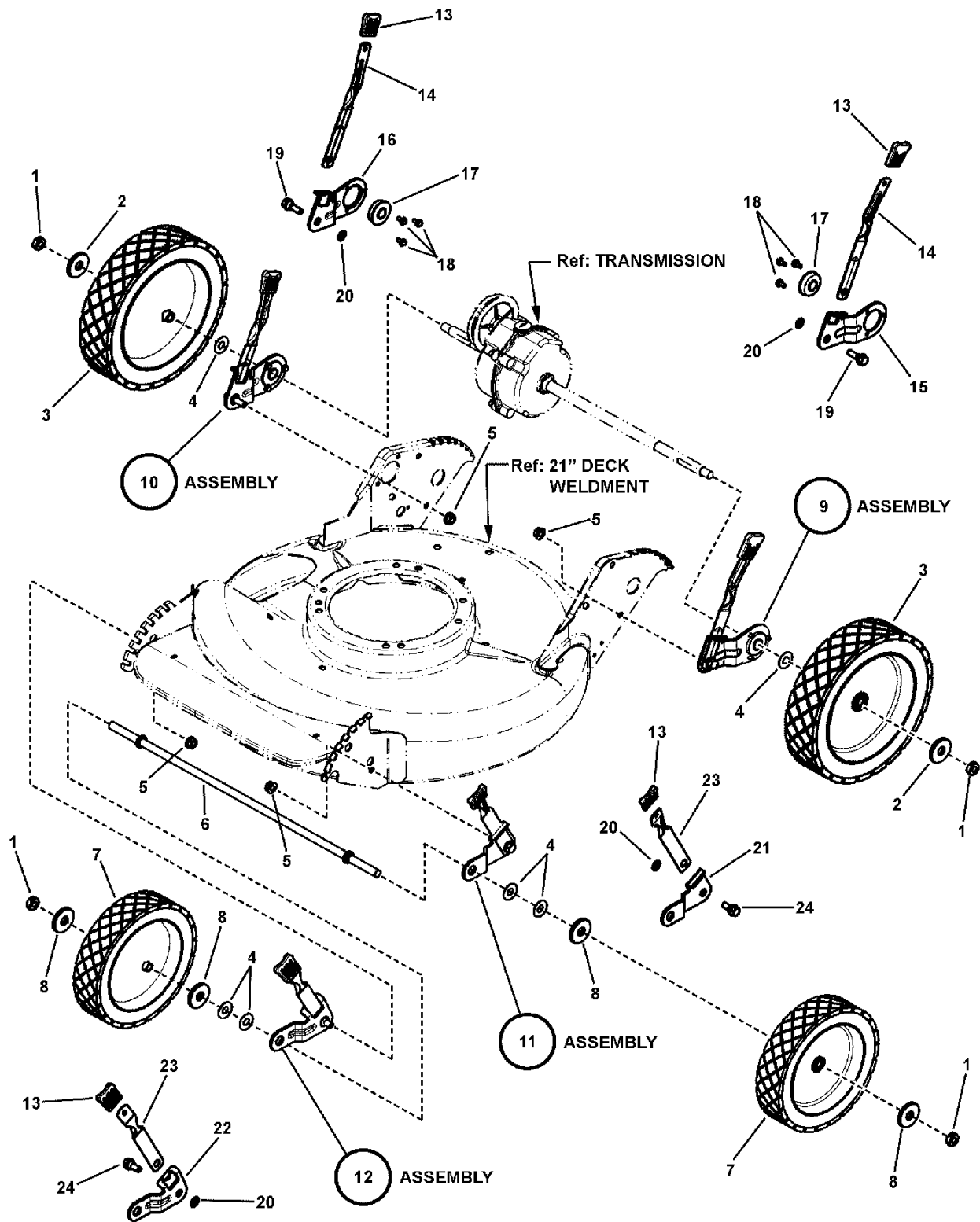

Wheel & Height-of-Cut Assembly Group

Item	Part No	Qty	Description
1	7090377	4	NUT, 7/16-20 Hex Center lock Jam, GR 5, YZ
2	7031960	2	HUBCAP
3	7035726	2	WHEEL, 10 x 1.75- Steel-D- (Self Propelled)- Gray
4	7031961	6	WASHER, 7/16" Flat
5	7091601	4	NUT, 5/16-18 Hex Flange Lock, GR 5 (Was 7091070)
6	7021119	1	AXLE, V21
7	7035727	2	WHEEL, 8 x 1.75- Steel - D- Gray
8	7031121	4	HUBCAP, V21
9	7054247	1	ASSEMBLY, Wheel Arm, Left Rear, Long (Was 7054231)
10	7054246	1	ASSEMBLY, Wheel Arm, Right Rear, Long (Was 7054230)
11	7051885	1	ASSEMBLY, Front Wheel Arm, LH
12	7051886	1	ASSEMBLY, Front Wheel Arm, RH
13	7100633	4	GRIP, Height Latch
14	7035717	2	LATCH, Height Adjusting, (long)
15	7032723	1	ARM, Wheel, Left Rear
16	7032722	1	ARM, Wheel, Right Rear
17	7012312	2	BEARING, 9/16" ID
18	7091012	6	SCREW, #10-32 x 3/8" Hex Washer Self-Tap, BZ
19	7011078	2	BOLT, 5/16-18 x 1" Hex Washer Face Shoulder
20	7011791	4	RETAINER, 5/16" Bolt
21	7031016	1	WHEEL ARM, L.H. Front (Square Hole)
22	7031017	1	WHEEL ARM, R.H. Front (Round Hole)
23	7012325	2	LATCH, Height
24	7015761	2	BOLT, 5/16-18 x 3/4" Hex Washer Face Shoulder

Footnotes:

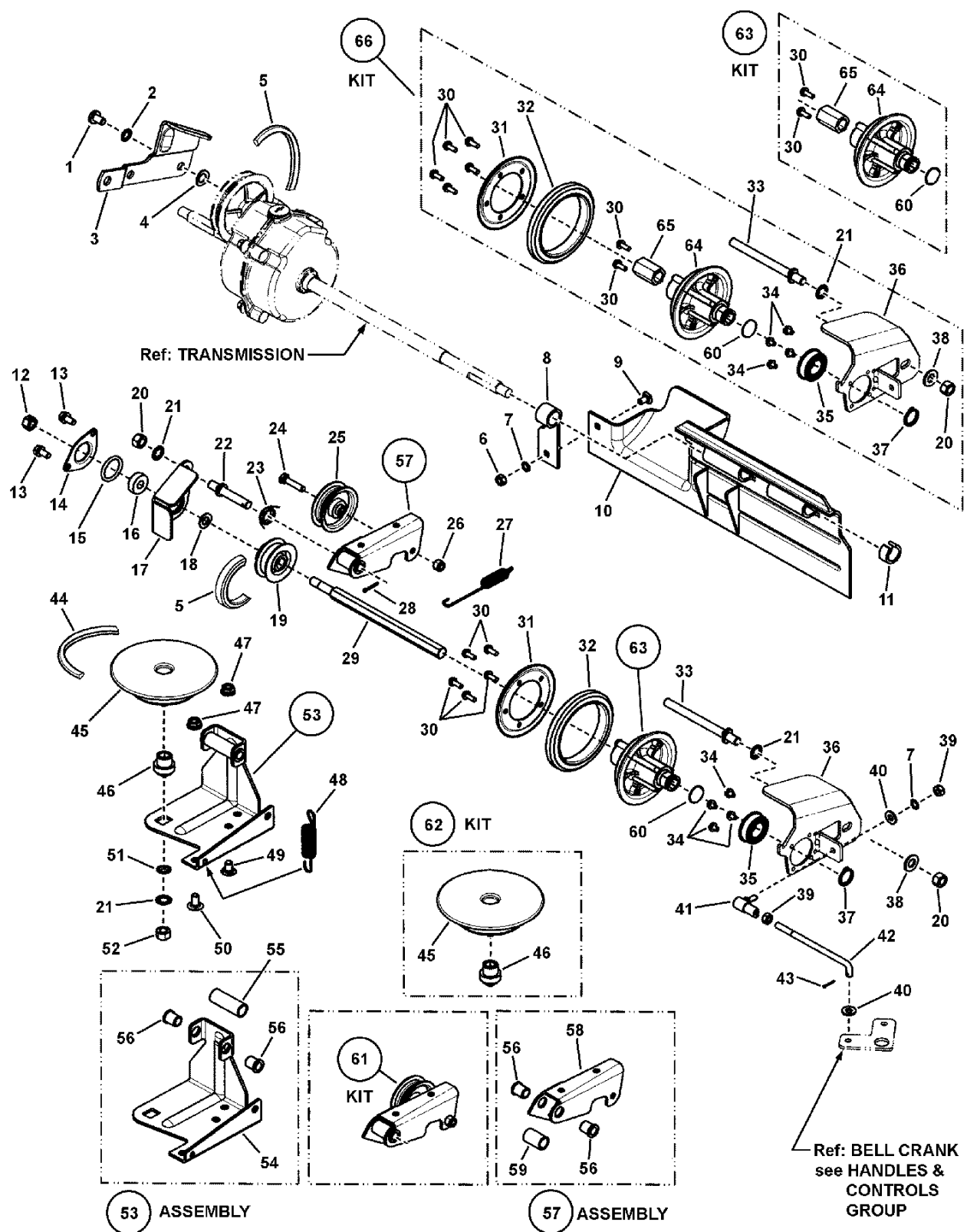

Item	Part No	Qty	Description
1	7091542	1	SCREW, 5/16-18 x 1/2" Pan Head Self-Tap (Torx)
2	7090391	1	WASHER, 5/16" Internal Tooth Lock
3	7034179A	1	LINK, Differential, Commercial
4	7011724	1	WASHER, Curved, .44 x .78 x .025 BZ
5	7012354	1	BELT, Poly-V, V21
6	7091576	1	NUT, 1/4-20 Hex, GR 5 or B, ZP (Was 7090063)
7	7090053	2	WASHER, 1/4" Internal Tooth Lock, YZ (Was 7091023)
8	7012616	1	SUPPORT, Guard
9	7091604	1	BOLT, 1/4-20 x 1/2" Short Square Neck Carriage, GR 5 (Was 7090005)
10	7029008	1	FOOT GUARD, 21"
11	7023791	1	RING, Split, .68 x .93 x .44 (Black)
12	7090289	1	NUT, 3/8-24 Hex Center lock, GR 5, YZ
13	7091122	2	SCREW, 1/-20 x 1/2" Hex Flange Self-Tap (Was 7090539)
14	7031809	1	HOLDER, Bearing (Outer Half)
15	7011025	1	O-RING, V21
16	7028014	1	BALL BEARING, Spherical O.D., .38 I.D.
17	7031873	1	HOLDER, Bearing (Inner Half)
18	7012316	1	WASHER, .390 I. D. Flat
19	7019383	1	PULLEY, Poly-V, 2.00 O.D.
20	7091630	2	NUT, 3/8-24 Hex, GR 5, YZ
21	7090390	3	WASHER, 3/8" Internal Tooth Lock, BZ
22	7012111	1	STUD, Idler, (3/8-24 thread) YZ
23	7012126	1	SPRING, V21
24	7091025	1	SCREW, 1/4-28 x 1-3/8" Hex Head Cap, GR 5
25	7012124	1	PULLEY, Idler, V21
26	7090303	1	NUT, 1/4-28 Hex Top Lock, GR 5, BZ
27	7012122	1	SPRING, Clutch (also shown on Handles & Controls Group page)
28	7091597	1	COTTER PIN, 3/32 x 1/2" (Was 7090555)
29	7072284	1	HEX SHAFT (Heat Treated)
30	7090913	7	SCREW, #10-24 x 1/2" Hex Washer Self-Tap (Torx)
31	7031013	1	SIDE PLATE, Drive Tire
32	7023364	1	DRIVEN RING (Was 7010927)
33	7012125	1	GUIDE, Thrust Plate (3/8-24 thread)
34	7090981	4	SCREW, #10-32 x 1/4" Hex Washer self-Tap
35	7029027	1	BALL BEARING, 3/4" Bore, Commercial
36	7300977A	1	THRUST PLATE, Short
37	7010746	1	RETAINING RING, .625 External
38	7090122	1	WASHER, 3/8" Flat
39	7090095	2	NUT, 1/4-28 Hex GR 5 or B, YZ (also shown on Handles & Controls Group page)
40	7091294	2	WASHER, .28 x .63 x .065, Flat, YZ
41	7015753	1	BALL JOINT (also shown on Handles & Controls Group page)
42	7074145	1	LINK, Transfer (1/4-28 thread)
43	7090673	1	COTTER PIN, .06 x .50, YZ (Was 7091629)
44	7046784	1	BELT, Engine Drive (Stretch)

Footnotes:

Drive System, Self-Propelled

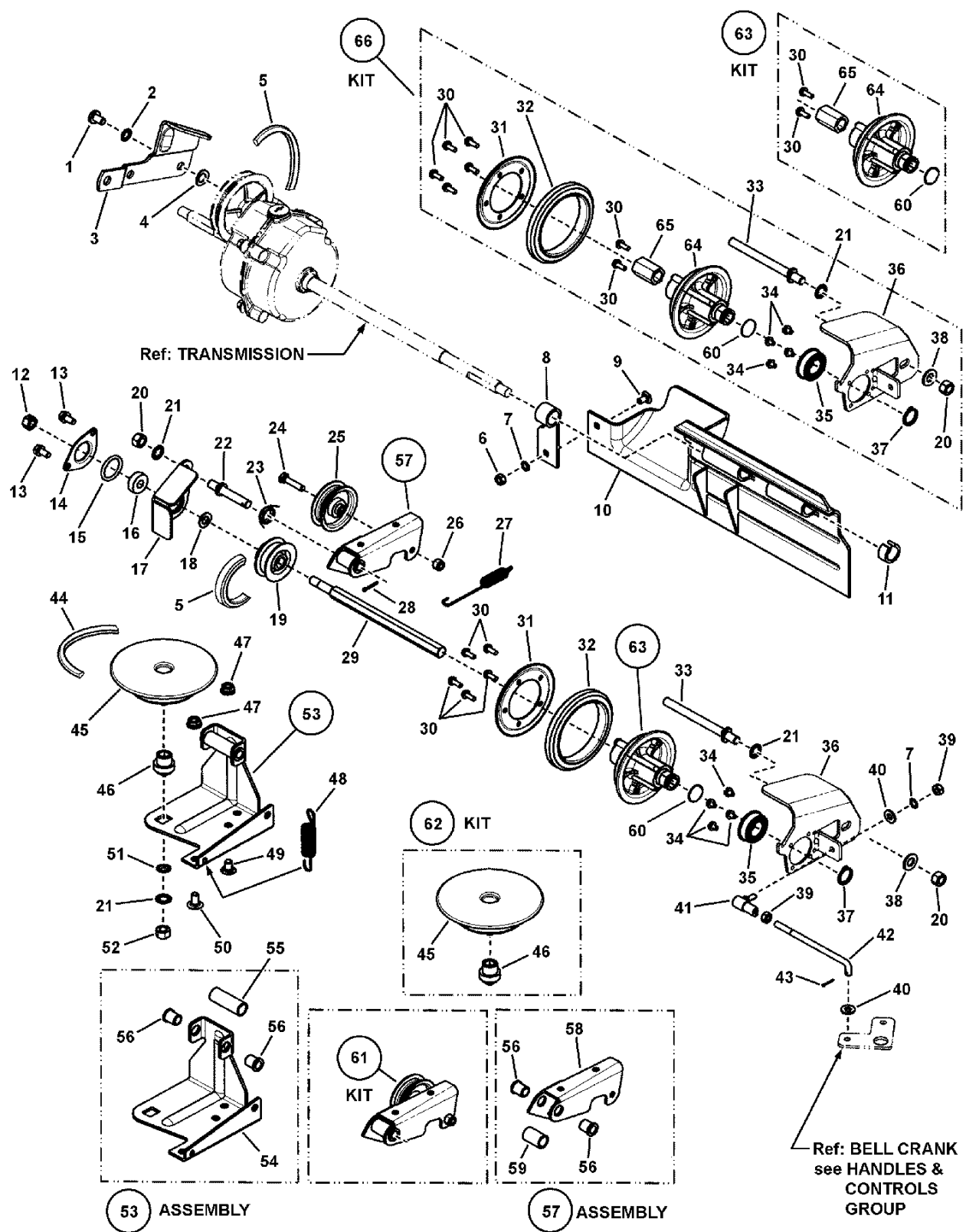

Item	Part No	Qty	Description
45	7073528	1	DRIVE DISC, Steel
46	7017696	1	BUSHING
47	7090585	2	NUT, 5/16-18 Hex Flange Lock, GR 5
48	7029025	1	SPRING, Extension, .58 x 3.2
49	7090731	1	BOLT, 5/16-18 x 1/2" Short Square neck Carriage, GR 5
50	7090799	1	BOLT, 5/16-18 x 5/8" Round Head Short Square Neck, GR 5 BZ (Was 7091026)
51	7011791	1	RETAINER, 5/16" Bolt
52	7091302	1	NUT, 3/8-16 Hex, GR 5, YZ
53	7052987A	1	ASSEMBLY, Deck Bracket, P21S
54	7033774	1	BRACKET, Deck, P21S
55	7021758	1	SPACER, .65 OD x .500 ID x 1.75 L
56	7012306	2	BUSHING, Flange
57	7500154	1	ASSEMBLY, Idler Arm (Bushing & Spacer)
58	7032832A	1	ARM, Clutch Idler
59	7100447	1	SPACER, Idler Arm
60	7010121	1	WASHER, Shim, .75X1.0X.021
61	7051913	1	ASSEMBLY, Clutch Idler (incl. items 24, 25, 26, 56 (2), 58 & 59)
62	7061275	1	ASSEMBLY, Drive Disc, Square, P21S (incl. items 45, 46, 52, & 7013893)
63	7061276	1	KIT, Hub & Bushing (Was 7053217)
64	7017073	1	HUB, Driven Disc
65	7011108	1	BUSHING, Drive, Hex
66	7600109	1	ASSEMBLY, Driven Disc, Short, Commercial, MY08 (incl. items 20, 21, 30, 31, 32, 33, 34, 35, 36, 37, 38, 60 & 63)

Footnotes:

Transmission - Differential Group

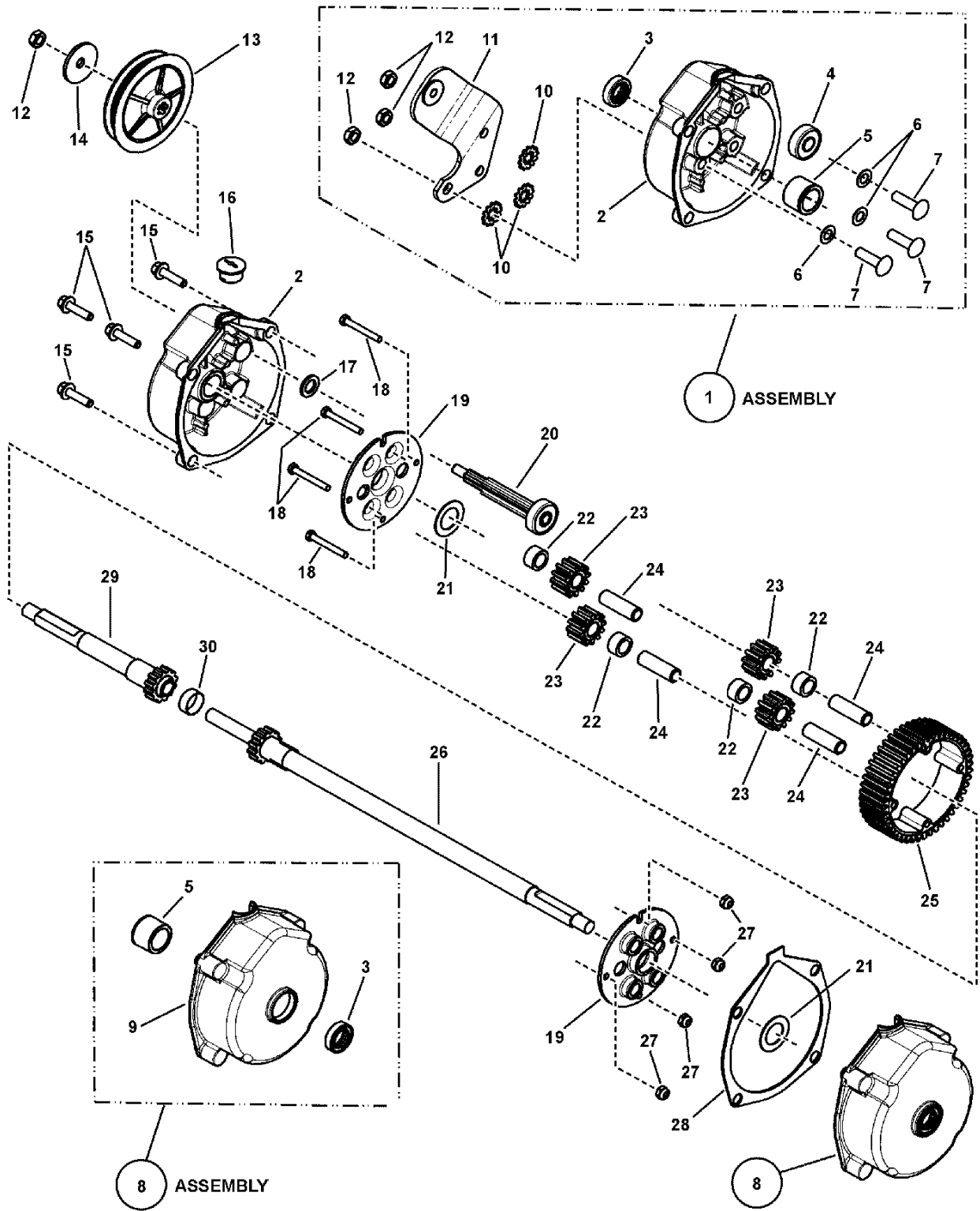

Transmission - Differential Group

Item	Part No	Qty	Description
--	7053943	1	ASSEMBLY, Transmission
1	7051908	1	ASSEMBLY, Right Hand Housing (Includes enclosed items)
2	7029034	1	HOUSING, Right Hand
3	7012314	1	SEAL, 5/8" ID
4	7073963	1	BALL BEARING, 1-1/8" O.D.
5	7029035	1	BEARING, Tapered, Differential Housing
6	7024442	3	GASKET, 5/8" O.D.
7	7014155	3	SCREW, 5/16-24 x 1-1/8" Rib Neck, GR 5
8	7053939	1	ASSEMBLY, Left Hand Housing
9	7029033	1	HOUSING, Left Hand
10	7090189	3	WASHER, 5/16" Internal/External Lock
11	7051903A	1	WELDMENT, Differential Bracket
12	7092062	4	NUT, 5/16-24 Lock, GR C, YZ (Gripco part no. TLA-5624-S-GRC)
13	7019213	1	PULLEY, Poly-V
14	7092063	1	WASHER, .32 x 1.40 x .1 Cone, YZ
15	7091825	4	SCREW, 1/4-20 x 1" Hex Washer Self-Tap, YZ (Was 7092064)
16	7016544	1	PLUG, Transmission
17	7091720	1	WASHER, .453 x .75 x .073 Flat, YZ
18	7090557	4	SCREW, #10-32 x 1-1/2" Hex Head Cap, GR 5
19	7031970	2	PLATE, V21
20	7050767	1	ASSEMBLY, Input Gear
21	7031965	2	WASHER, Thrust, V21
22	7012500	4	SPACER, .700 OD x .480 ID x .380 L
23	7021115	4	GEAR, Differential Pinion, V21
24	7011110	4	SHAFT, V21
25	7012495	1	* GEAR, Differential (46 Tooth), V21
26	7050831	1	ASSEMBLY, Long Axle (Was 7051933)
27	7090376	4	NUT, #10-32 Hex Nyloc
28	7011774	1	GASKET, V21
29	7050830	1	ASSEMBLY, Short Axle (Was 7051932)
30	7012543	1	SPACER, .820 OD x .720 ID x .330 L
--	7061017	32oz.	** "00" Grease (Not shown)

Footnotes:

NOTE: * 7060337 KIT, Transmission Gear (Incl. items 18, 19, 21, 22, 23, 24, 25, 27 & 30).

NOTE: ** Maximum capacity of transmission before causing leakage behind pulley is 4 oz. DO NOT OVERFILL!

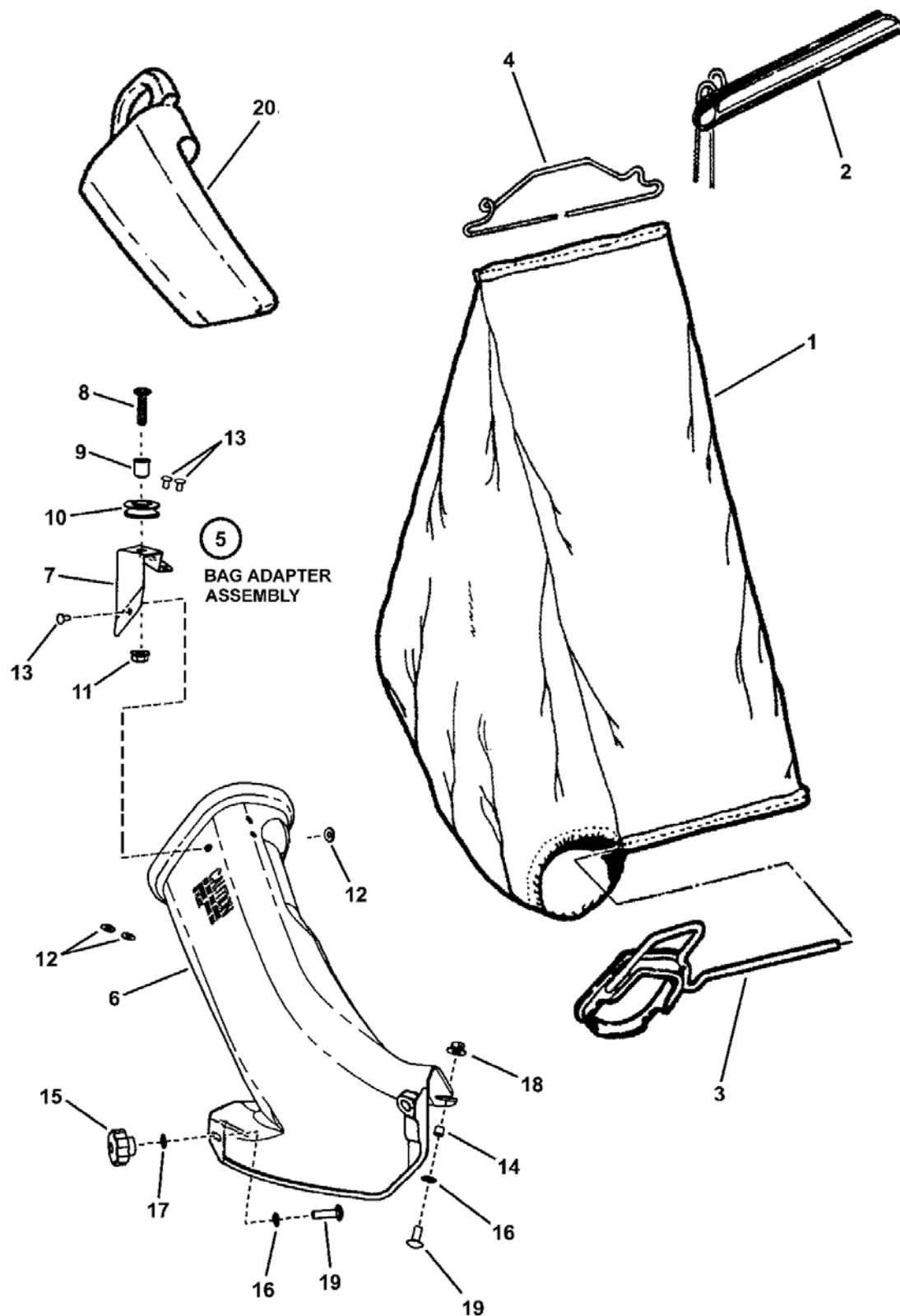

Item	Part No	Qty	Description
--	7501482	1	ASSEMBLY, Grass Bag (Slider Type, No Graphics) (replaces 7058572)
1	7103205	1	GRASS BAG, Res. Slider w/o Graphics (replaces 7075766)
2	7050711	1	ASSEMBLY, Slider
3	7042489A	1	WELDMENT, Bag Connector
4	7019247	1	WIRE, Rear Bag
5	7058037	1	ASSEMBLY, Bag Adapter
6	7047081	1	BAG ADAPTER, 21
7	7047082A	1	BRACKET, Rope Pulley
8	7091984	1	SCREW, 5/16-18 x 1-1/4" Pan Head Machine
9	7012306	1	BUSHING, Flange
10	7024228	1	PULLEY, Nylon
11	7091601	1	NUT, 5/16-18 Hex Flange Lock, GR 5, YZ
12	7072107	3	WASHER, 5/32" Flat
13	7013860	3	RIVET, 3/16 x .344
14	7024340	1	SPACER, .316 I.D. x .375 O.D. x .310 thick
15	7101022	2	KNOB, Fluted, 5/16-18 x 1/2"
16	7011791	4	RETAINER, 5/16" Bolt
17	7091076	1	WASHER, 5/16" Flat
18	7090951	1	NUT, 5/16-18 Hex Large Flange Center Lock
19	7091508	2	BOLT, 5/16-18 x 3/4" Short Neck Carriage GR 5
20	7016814	1	PLUG, Chute Adapter (accessory item)
--	7060440		KIT, Snapperizer (21" Hi-Vac Steel Deck Models) (other accessories not shown)
--	7063041		KIT, Snapperizer (21" F & M Outlip Steel Deck Models) (other accessories not shown)
--	7061200		KIT, Recycling Cover (other accessories not shown)
--	7061201		KIT, Recycling Plug (Quad Blade) (other accessories not shown)
--	7061256		KIT, Thatcherizer (other accessories not shown)

Footnotes:

Side Chute, Adapter

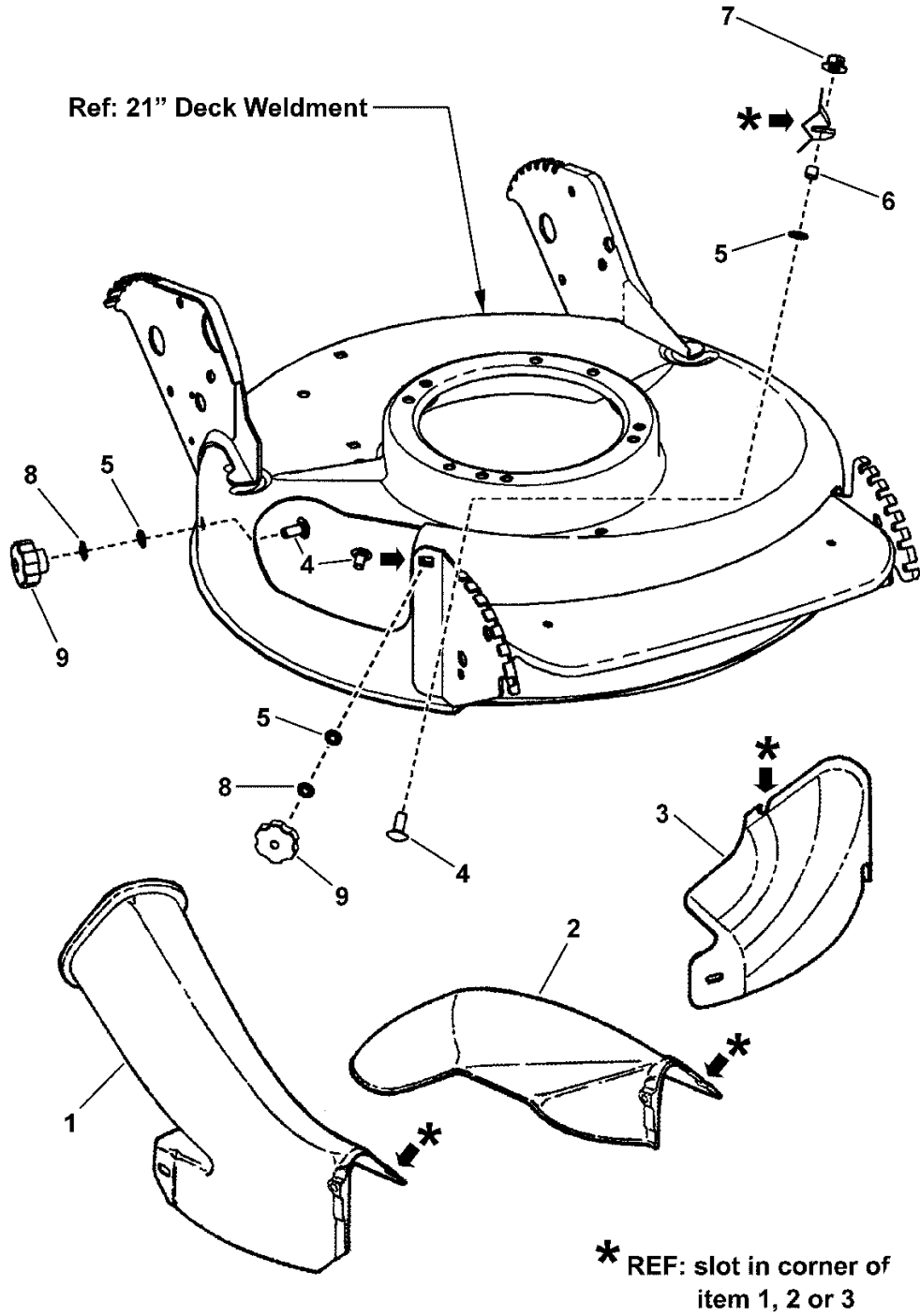

Item	Part No	Qty	Description
1	7047081	1	BAG ADAPTER, 21
2	7042965	1	CHUTE, 21" Side (accessory part)
3	7029149	1	COVER, 21" Deck
4	7091508	3	BOLT, 5/16-18 x 3/4" Short Neck Carriage GR 5 (Was 7090001)
5	7011791	1	RETAINER, 5/16" Bolt
6	7024340	1	SPACER, .316 I.D. x .375 O.D. x .310 thick
7	7090951	1	NUT, 5/16-18 Hex Large Flange Center Lock
8	7090189	2	WASHER, 5/16" Internal/External Lock
9	7101022	2	KNOB, Fluted, 5/16-18 x 1/2"

Not for
Reproduction

Footnotes:

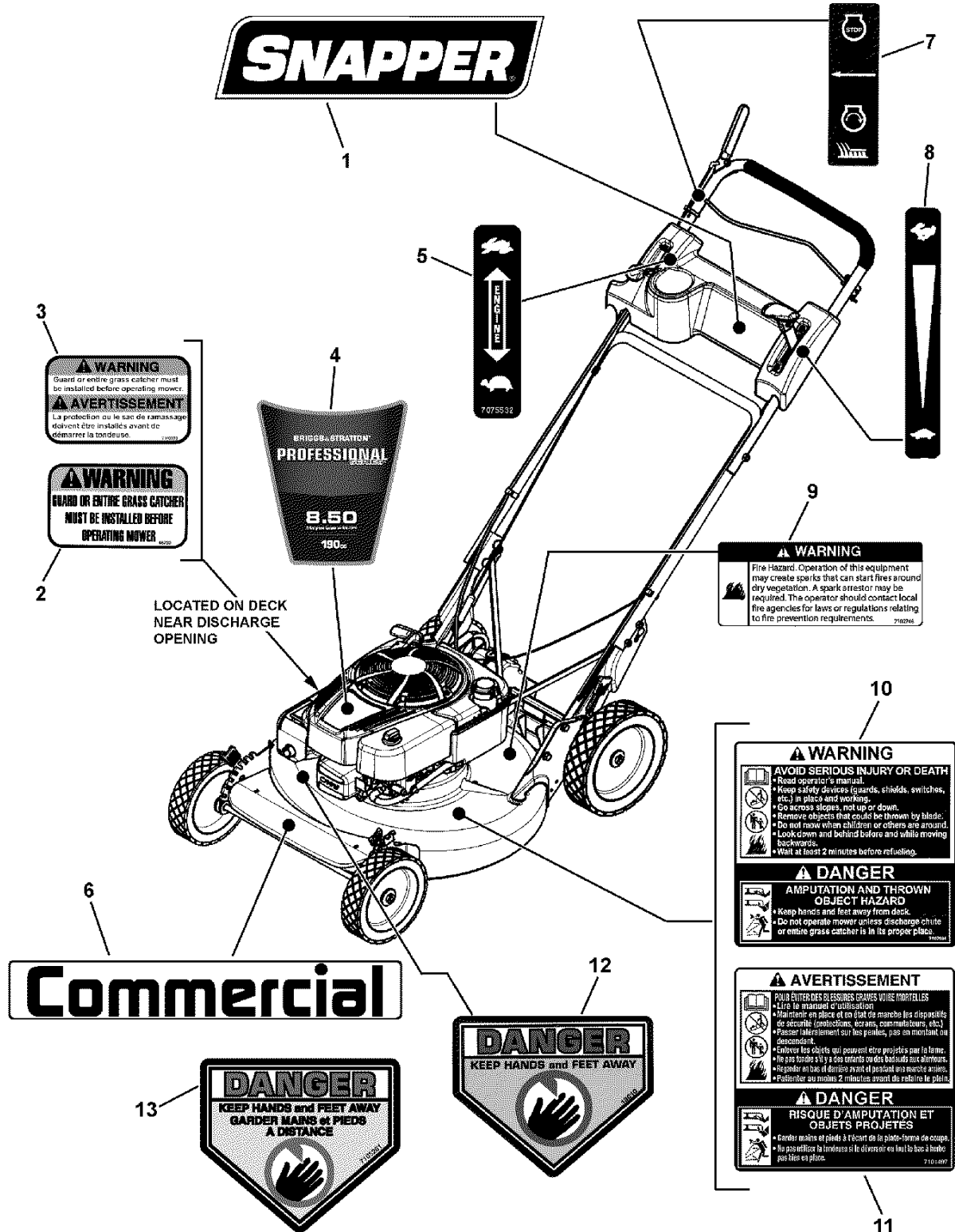

Item	Part No	Qty	Description
1	7104148	1	DECAL, Logo, Snapper, 7.88" (used on all 4 models)
2	7046720	1	DECAL, Chute Deflector (used on 7800772 & 7800764 models)
3	7102324	1	DECAL, Chute/Deflector FC (used on 7800847 & 7800848 models)
4	278279	1	DECAL, 8.50T/190cc Professional Series (used on 7800772 & 7800764 models)
5	7075532	1	DECAL, Throttle Control, B&S (used on all 4 models)
6	7104873	1	DECAL, Snapper, Steel Deck (used on all 4 models)
7	7029782	1	DECAL, OPC Bail International Symbol (used on all 4 models)
8	7075471	1	DECAL, Speed Shift (used on all 4 models)
9	7102746	1	DECAL, Spark Arrestor (used on all 4 models)
10	7100984	1	DECAL, Warning/Danger, Walk-Behind-Mower (used on all 4 models)
11	7101497	1	DECAL, Warning/Danger, French/English (used on 7800847 & 7800848 models)
12	7013010	1	DECAL, Danger, Cut Finger (used on 7800772 & 7800764 models)
13	7105261	1	DECAL, CPSC, French/English (used on 7800847 & 7800848 models)

Not for
Reproduction

Footnotes:

Not for
Reproduction

Hardware Identification & Torque Specifications

Torque Specification Chart FOR STANDARD METRIC MACHINE HARDWARE (Tolerance ± 20%)								
Property Class	5.6 Class 5.6		8.8 Class 8.8		10.9 Class 10.9		12.9 Class 12.9	
	in/lbs ft/lbs	Nm.	in/lbs ft/lbs	Nm.	in/lbs ft/lbs	Nm.	in/lbs ft/lbs	Nm.
M3	5.88	.56	13.44	1.28	19.2	1.80	22.92	2.15
M4	13.44	1.28	30.72	2.90	43.44	4.10	52.56	4.95
M5	26.4	2.50	60.96	5.75	5.97	8.10	7.15	9.7
M6	44.64	4.3	7.3	9.9	10.3	14	12.1	16.5
M7	5.2	7.1	12.1	16.5	16.9	23	19.9	27
M8	7.7	10.5	17.7	24	25	34	29	40
M10	15	21	35	48	50	67	59	81
M12	26	36	61	83	86.2	117	103	140
M14	42	58	101	132	136	185	162	220
M16	64	88	147	200	210	285	250	340
M18	89	121	202	275	287	390	346	470
M20	126	171	290	390	405	550	486	660
M22	169	230	390	530	559	745	656	890
M24	217	295	497	375	708	960	840	1140
M27	320	435	733	995	1032	1400	1239	1680
M30	435	590	995	1350	1401	1900	1681	2280
M33	590	800	1349	1830	1902	2580	2278	3090
M36	759	1030	1740	2360	2441	3310	2935	3980
M39	988	1340	2249	3050	3163	4290	3798	5150

Torque Specification Chart FOR STANDARD MACHINE HARDWARE (Tolerance ± 20%)						
Hardware Grade	No Marks SAE Grade 2		SAE Grade 5		SAE Grade 8	
	in/lbs ft/lbs	Nm.	in/lbs ft/lbs	Nm.	in/lbs ft/lbs	Nm.
8-32	19	2.1	30	3.4	41	4.6
8-36	20	2.3	31	3.5	43	4.9
10-24	27	3.1	43	4.9	60	6.8
10-32	31	3.5	49	5.5	68	7.7
1/4-20	66	7.6	8	10.9	12	16.3
1/4-28	76	8.6	10	13.6	14	19.0
5/16-18	11	15.0	17	23.1	25	34.0
5/16-24	12	16.3	19	25.8	29	34.0
3/8-16	20	27.2	30	40.8	45	61.2
3/8-24	23	31.3	35	47.6	50	68.0
7/16-14	30	40.8	50	68.0	70	95.2
7/16-20	35	47.6	55	74.8	80	108.8
1/2-13	50	68.0	75	102.0	110	149.6
1/2-20	55	74.8	90	122.4	120	163.2
9/16-12	65	88.4	110	149.6	150	204.0
9/16-18	75	102.0	120	163.2	170	231.2
5/8-11	90	122.4	150	204.0	220	299.2
5/8-18	100	136	180	244.8	240	326.4
3/4-10	160	217.6	260	353.6	386	525.0
3/4-16	180	244.8	300	408.0	420	571.2
7/8-9	140	190.4	400	544.0	600	816.0
7/8-14	155	210.8	440	598.4	660	897.6
1-8	220	299.2	580	788.8	900	1,244.0
1-12	240	326.4	640	870.4	1,000	1,360.0

The guides and ruler furnished below are designed to help you select the appropriate hardware.

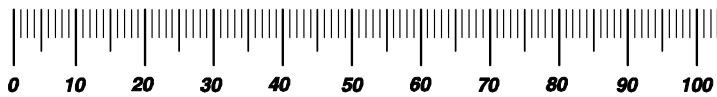

Nut, M8

Thread Diameter (mm)
Inside Diameter (in) Threads per inch

Nut, 1/2-16

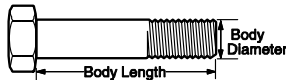

Screw, M8- 1.25 x 25

Thread Diameter (mm) Distance between threads (mm) Body Length (mm)
Body Diameter Threads per inch Body Length (in)

Screw, 1/2- 16 x 2

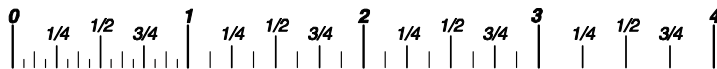

Standard Hardware Sizing

When a washer or nut is identified as 1/2" (M8), this is the *Nominal size*, meaning the *inside diameter* is 1/2 inch (8mm metric thread diameter); if a second number is present it represents the *threads per inch* (distance between threads).

When bolt or capscrew is identified as 1/2 - 16 x 2" (M8 - 1.25 x 50), this means the *Nominal size*, or body diameter is 1/2 inch (8mm metric thread diameter), the second number, 16, represents the *threads per inch*, (1.25 thread diameter). The final number is the body length of the bolt or screw, 2 inches (50mm).

NOTES

- These torque values are to be used for all hardware excluding: locknuts, self-tapping screws, thread forming screws, sheet metal screws and socket head setscrews.
- Recommended seating torque values for locknuts:
 - for prevailing torque locknuts - use 65% of grade 5 torques.
 - for flange whizlock nuts and screws - use 135% of grade 5 torques.
- Unless otherwise noted on assembly drawings, all torque values must meet this specification.

Common Hardware Types

Hex Head Capscrew



Washer



Carriage Bolt



Lockwasher



Hex Nut



Wrench & Fastener Size Guide

1/4" Bolt or Nut Wrench—7/16"	5/16" Bolt or Nut Wrench—1/2"	3/8" Bolt or Nut Wrench—9/16"	7/16" Bolt or Nut Wrench (Bolt)—5/8" Wrench (Nut)—11/16"	1/2" Bolt or Nut Wrench—3/4"
M6 Bolt or Nut Wrench—10mm	M8 Bolt or Nut Wrench—13mm	M10 Bolt or Nut Wrench—17mm	M12 Bolt or Nut Wrench—19mm	M14 Bolt or Nut Wrench—22mm

Parts Manual for

SNAPPER®

21" STEEL DECK WALK BEHIND COMMERCIAL MOWERS SERIES 20

Not for
Reproduction

IT IS THE POLICY OF BRIGGS & STRATTON CORP TO IMPROVE ITS PRODUCTS WHENEVER IT IS POSSIBLE AND PRACTICAL TO DO SO. WE RESERVE THE RIGHT TO MAKE CHANGES OR ADD IMPROVEMENTS AT ANY TIME WITHOUT INCURRING ANY OBLIGATION TO MAKE SUCH CHANGES ON PRODUCTS

Briggs & Stratton Yard Power Products Group

535 Macon Road
McDonough, GA, 30253 U.S.A.
800-935-2967

www.snapper.com

Copyright © 2012 Briggs & Stratton Corporation
Milwaukee, WI USA. All Rights Reserved

Manual No. 7104803

Revision: B 1/19/2012