



Parts Manual

Mfg. No: 2691023-00
NXT2242, 42" 22 HP NXT200 Lawn
Tractor LT125 Series

1692125 - Cart, Dump (10 Cu. Ft.)
1691319SM - Suitcase Weights, 33Lbs.
1690555SM - Weight, Rear Wheel (1 Each).....
1690163SM - Chains, Tire Pr. (20 X 8).....
1695641YP - Dethatcher, Tow- Behind, 40".....
1695969 - Snowthrower, Single Stage, 42".....
1695791 - Tiller, Tow Behind, 36".....
1695592 - Catcher, Clean Sweep Twin, 38" & 42".....
1695092SM - Tire Chains (22 x 10 - 8/10, 22 x 9.5 - 12).....
1696092 - Dozer Blade, 42".....
1696093 - Grass Mulcher Kit, 42".....
1696423-00 - Snowthrower, Single Stage, 42".....
1695966 - Sun Shade.....
1696088 - Front Bumper Kit.....
1695592-01 - Catcher, Clean Sweep Twin, 38" & 42".....
1695592A-00 - Catcher, Clean Sweep Twin, 38" & 42".....

Not For
Reproduction

Model Components	Page
42" Mower Deck - Clutch Group.....	4
42" Mower Deck - Height Adjustment & Roller Bar Group.....	6
42" Mower Deck - Housing, Arbor & Blades Group.....	8
Controls Group.....	10
Decals Group - 42", 46" & 52" Deck - Lockup.....	12
Electrical Group.....	14
Engine Group - 22, 23, 25, 26 & 27HP Briggs & Stratton EFM Twin Professional Series.....	18
Frame & Front Axle Group.....	20
Hood, Grille & Dash Group - Embossed.....	22
Lift Group - Electric.....	24
Seat Deck & Fuel Tank Group - EVAP Compliant (22GT, 23GT, 25GT, 26GT & 27GT).....	26
Steering Group.....	28
Transmission Group.....	30
Transmission SERVICE PARTS - Tuff Torq K46BP.....	32
Wheels & Tires Group.....	36
Torque Specification Chart.....	38

Not For
Reproduction

42" Mower Deck - Clutch Group

Note: Unless noted otherwise, use the standard torque specifications

Mfg. No: 2691023-00

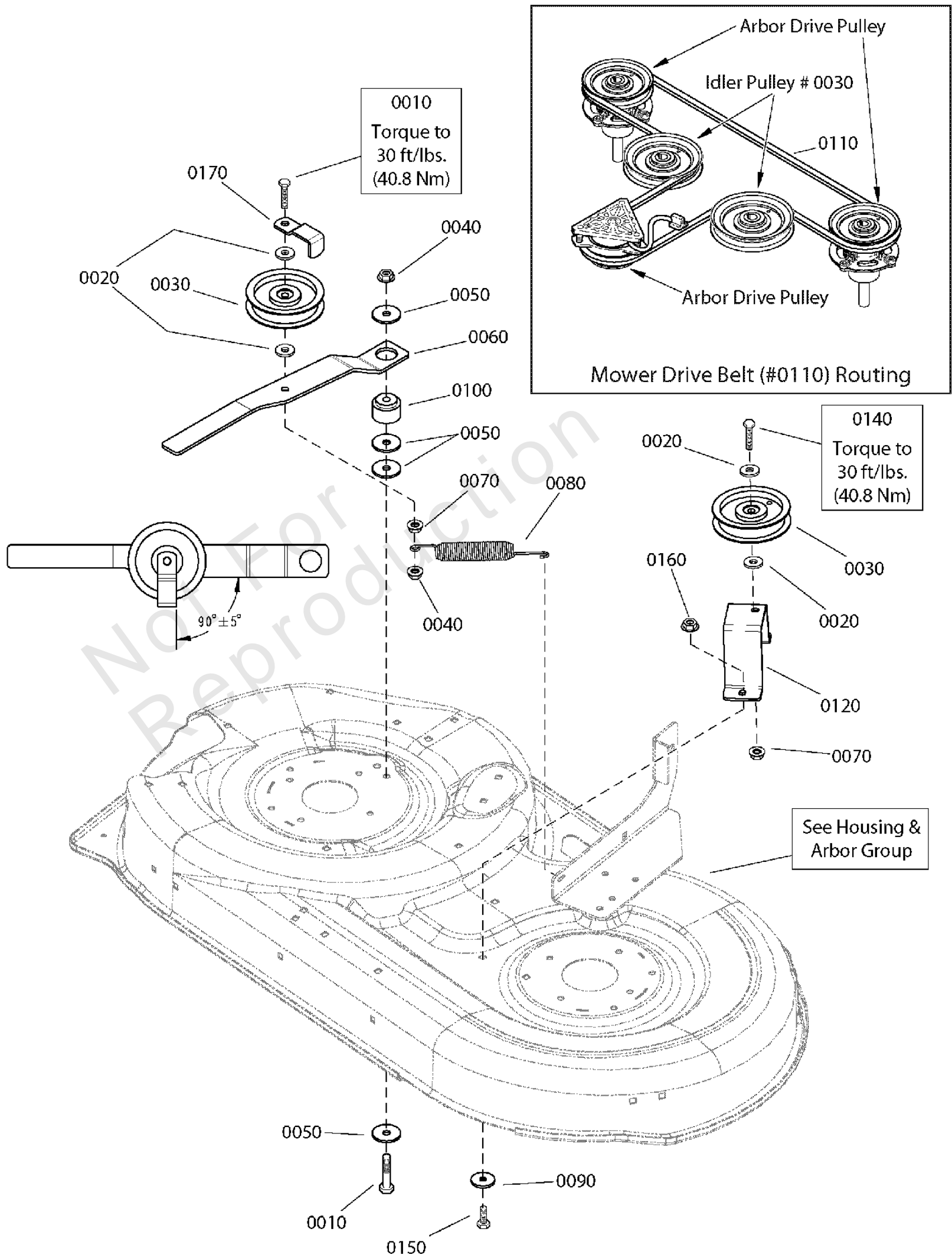

42" Mower Deck - Clutch Group

REF NO	PART NO	QTY	DESCRIPTION
0010	1922130	2	CAPSCREW, Hex Head, 3/8-16 x 2-1/4, G5
0020	1922755	4	WASHER, 3/8 x 1 OD
0030	7018574	2	IDLER, Flat, 4-1/8
0040	1960339	2	NUT, Hex Flange, 3/8-16, Locking
0050	1924356	4	WASHER, 3/8 x 1-1/2 OD
0060	1731944A	1	ARM, Idler
0070	1931211	2	NUT, Hex Flange Whiz Lock, 3/8-16
0080	1731311	1	SPRING, Extension, 1-1/32 OD x 7-3/4
0090	1933468	2	WASHER, 5/46 x 1-1/4 OD
0100	1729007	1	SPACER, 3/8 ID X 1-1/2 OD x 1-1/32
0110	1732955	1	V-BELT, A Wedge Deep-Groove, .44"
0120	1731911A	1	SUPPORT, Idler
0140	1921971	1	CAPSCREW, Hex Head, 3/8-16 x 1-3/4, G5
0150	1923325	2	CAPSCREW, Hex Head, 5/16-18 x 7/8, G5
0160	1931277	2	NUT, Hex Flange Whiz Lock, 5/16-18
0170	1732884A	1	GUARD, Spring

42" Mower Deck - Height Adjustment & Roller Bar Group

Note: Unless noted otherwise, use the standard torque specifications

Mfg. No: 2691023-00

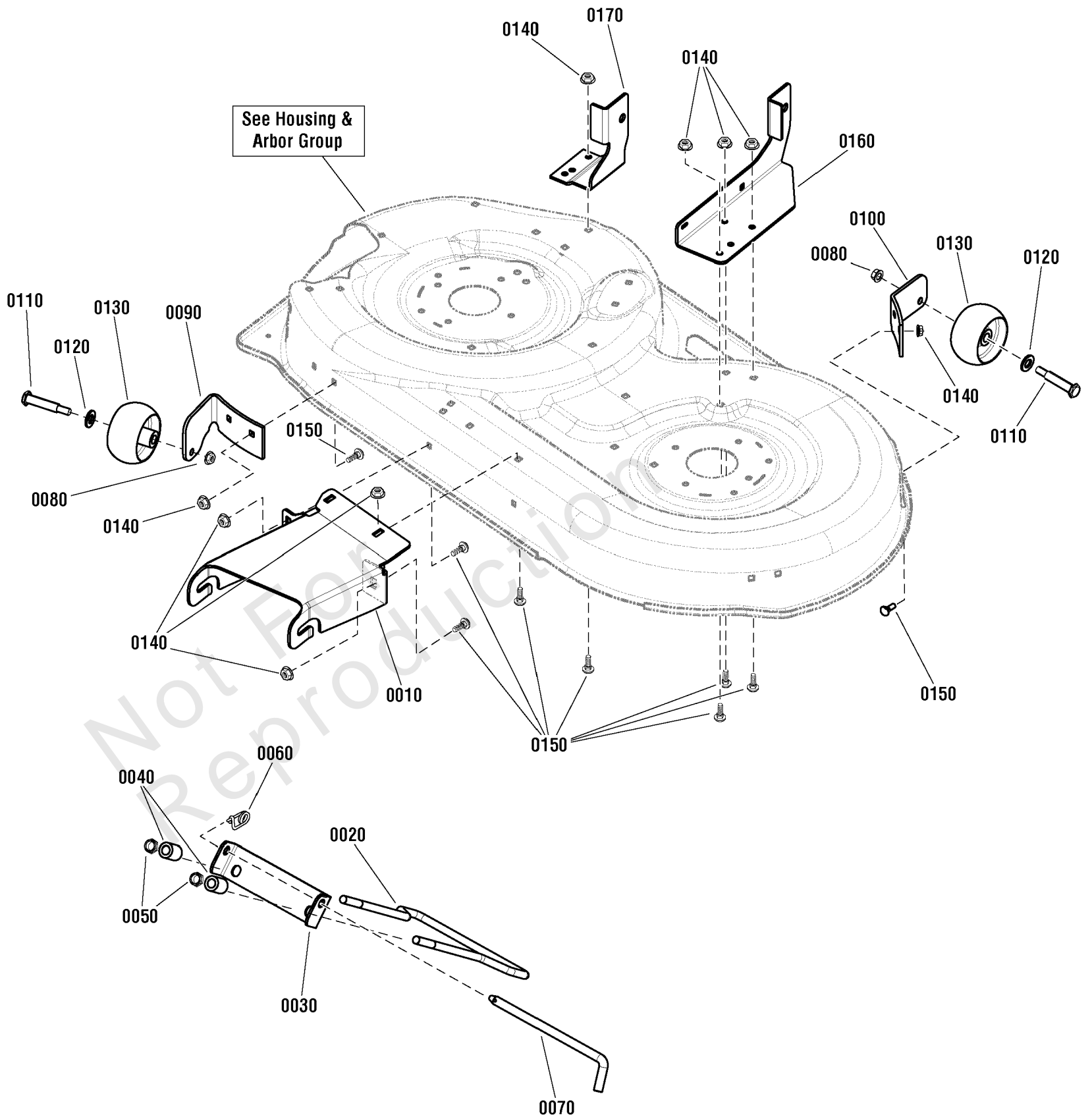

42" Mower Deck - Height Adjustment & Roller Bar Group

REF NO	PART NO	QTY	DESCRIPTION
0010	1731966D	1	HITCH, Front
0020	1730097	1	ROD, 1/2 Dia., 1/2-13
0030	1730221A	1	HANGER, Front
0040	1679166	2	SPACER, 1/2 ID x 7/8 OD x 1-3/16 Long
0050	1960379	2	NUT, Hex Lock, ESNA, 1/2-13
0060	2176012	1	RETAINER, Pin Spring
0070	1731414	1	ROD, Latch, 1/2 Dia. x 9" Long
0080	1960687	2	NUT, Hex Flange, ESNA, 3/8-16
0090	1731402A	1	SUPPORT, Gauge, Wheel, R.H.
0100	1731403A	1	SUPPORT, Gauge, Wheel, L.H.
0110	2108765	2	BOLT, Wheel, 3/8-16 x 2-3/4
0120	1960170	2	WASHER, 1/2 x 1 OD
0130	1714760	2	WHEEL, 2W 3-7/8 Dia. x 17/32 ID
0140	1931277	13	NUT, Hex Flange Whiz Lock, 5/16-18
0150	1931333	13	BOLT, Carriage, 5/16-18 x 3/4, G5
0160	1730071D	1	SUPPORT, Mower, L.H.
0170	1730072D	1	SUPPORT, Mower, R.H.

42" Mower Deck - Housing, Arbor & Blades Group

Note: Unless noted otherwise, use the standard torque specifications

Mfg. No: 2691023-00

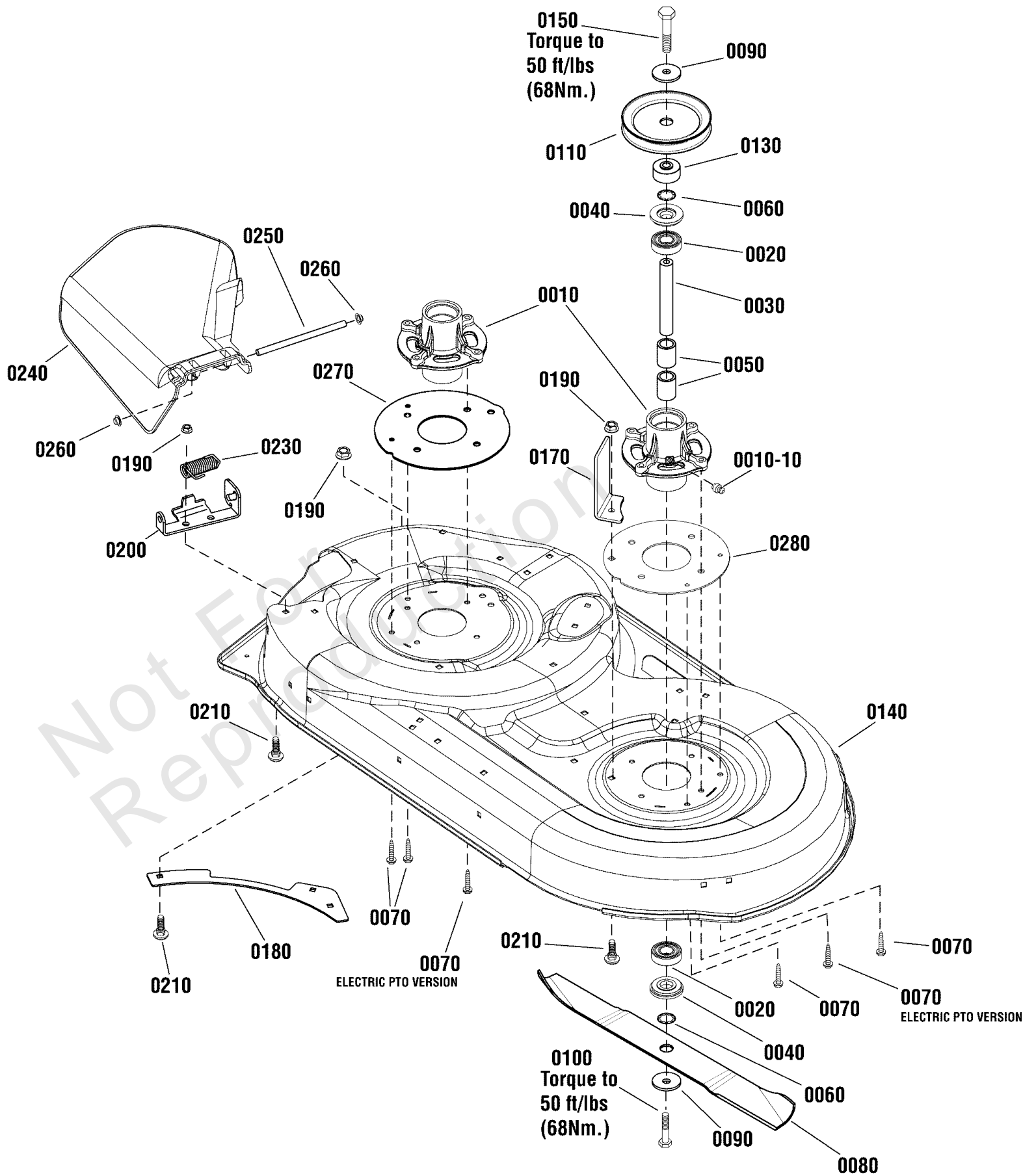

42" Mower Deck - Housing, Arbor & Blades Group

REF NO	PART NO	QTY	DESCRIPTION
0010	1737352	2	HOUSING, Spindle
0010-10	1704314	1	FITTING, Lubrication
0020	1735399	4	BEARING, Ball, 20mm
0030	1735326	2	SHAFT, Spindle, 20mm Dia. x 134.6mm
0040	1735323	4	SHIELD, Arbor, 2-1/16 OD
0050	1735328	4	SPACER, Bearing
0060	1960766	4	RING, Self Locking
0070	1960373	12	CAPSCREW, Hex Washer Head, Taptite, 5/16-18 x 1
0080	1737816	2	BLADE, 42" Mower, 21.16" Long
0090	1656916	4	WASHER, Spring, 15/32 ID x 1-3/4 OD
0100	1920676	2	CAPSCREW, Hex Head, 7/16-14 x 1, G5
0110	1737835	2	PULLEY, V, Deep Groove
0130	1737457	2	SPACER, Pulley
0140	1736504D	1	HOUSING, 42" Mower Deck
0150	1923027	2	CAPSCREW, Hex Head, 7/16-14 x 1-3/4, G5
0170	1737845A	1	UPSTOP
0180	721083A	2	PLATE, Rear
0190	1931277	7	NUT, Hex Flange, Whiz Lock, 5/16-18
0200	721369A	1	BRACKET, Hinge
0210	1931333	7	BOLT, Carriage, 5/16-18 x 3/4, G5
0230	720154	1	SPRING, Torsion
0240	721339	1	DEFLECTOR & SUPPORT ASSEMBLY, Chute
0250	721371	1	ROD, DEFLECTOR
0260	1960093	2	NUT, Push Pal, 3/8
0270	1750457BM	1	PLATE, Spindle RH
0280	1750458BM	1	PLATE, Spindle LH

Controls Group

Note: Unless noted otherwise, use the standard torque specifications

Mfg. No: 2691023-00

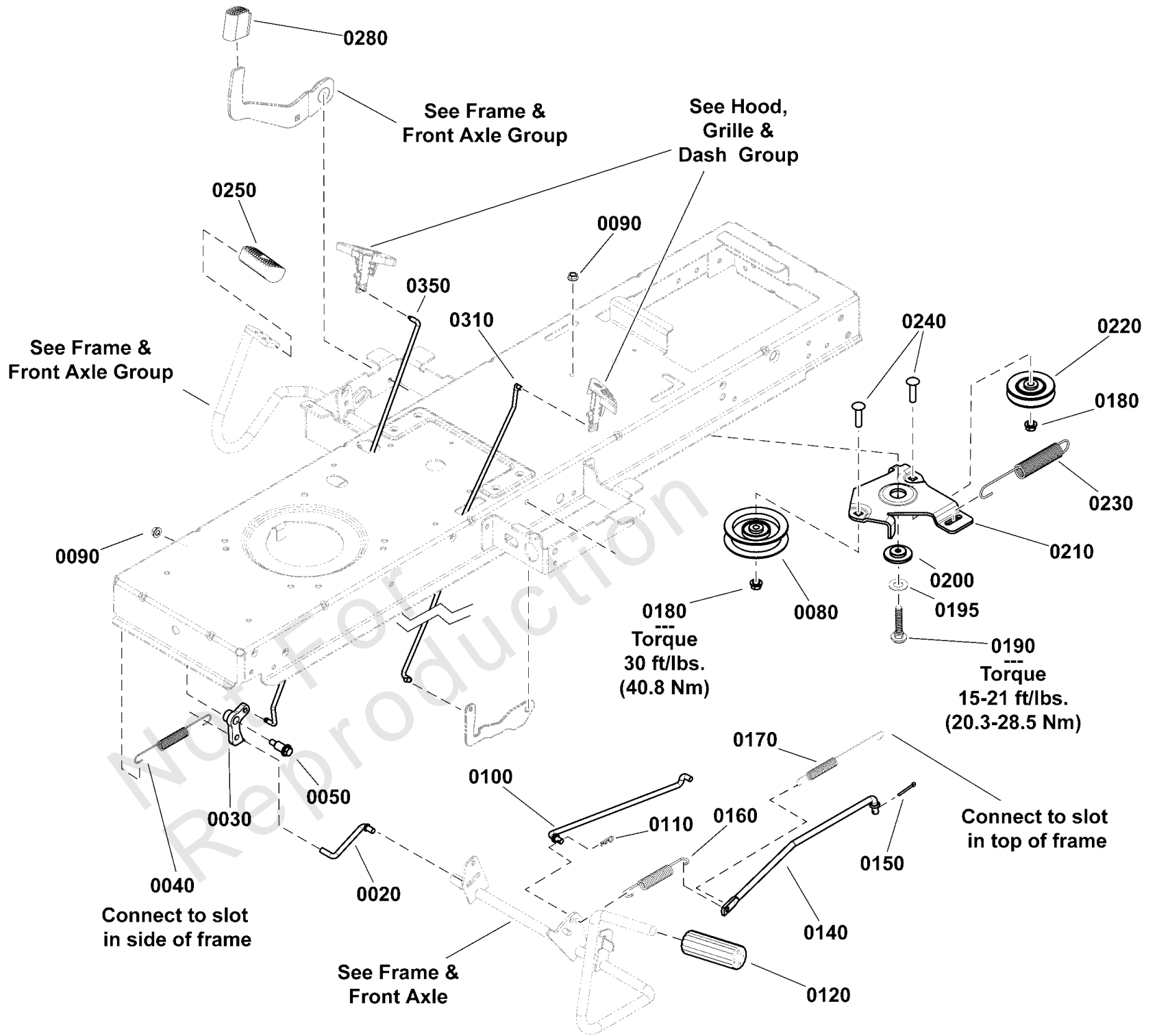

Controls Group

REF NO	PART NO	QTY	DESCRIPTION
0020	1727899SM	1	ROD, Cruise Latch, 5/16 Dia. x 2-13/16 Long
0030	1727897SM	1	LATCH, Cruise
0040	2159181SM	1	SPRING, Extension, 9/16 OD x 7-3/4 LG, .049 Wire
0050	1728976SM	1	BOLT, Shoulder, 5/16-18 x 1-5/8
0080	1728000SM	1	PULLEY, Idler, 3-1/8 OD, 3/8 ID
0090	703115	2	NUT, Flange Nylock, 5/16-18
0100	1727254SM	1	ROD, Brake Return, 5/16 Dia. x 12-5/8 Long
0110	703430	1	HAIRPIN, Quick, .080 Wire, 1.19LG, Zinc/Clear
0120	1727261SM	1	PEDAL, Brake Rubber
0140	1727253SM	1	ROD, Brake, 3/8 Dia. x 15-1/8 Long
0150	703312	1	PIN, 3/32 X 3/4, GR5, Cotter, Zinc/Clear
0160	1731262SM	1	SPRING, Extension, 11/16 x 3-3/8
0170	1721995SM	1	SPRING, Extension, 5/8 x 6-5/8
0180	703158	2	NUT, 3/8-16, Hex Flange, ESNA, Zinc/Clear
0190	703585	1	CAPSCREW, Hex Head, 5/16-18 x 1
0195	1919326SM	1	WASHER, 5/16
0200	1727935SM	1	SPACER, Pivot, 0.330 ID, 1.76 OD, .37TH P MTL
0210	1727894SM	1	BRACKET, Idler
0220	1728001SM	1	PULLEY, Idler, 3-1/8 OD, 3/8 ID
0230	1729620SM	1	SPRING, .98 OD X 7.52" LG, .11 Wire, Extension, Blk
0240	1931352SM	2	BOLT, Carriage, Short Neck, 3/8-16 x 1-1/2
0250	1721675SM	1	PAD, Forward Foot Pedal, Black Rubber
0280	1727259SM	1	PAD, Reverse Foot Pedal, Black Rubber
0310	1739876YP	1	ROD, Parking Brake, 1/4 Dia. x 16-3/8 Long
0350	1739877YP	1	ROD, Cruise, 1/4 Dia. x 17

Decals Group - 42", 46" & 52" Deck - Lockup

Note: Unless noted otherwise, use the standard torque specifications

Mfg. No: 2691023-00

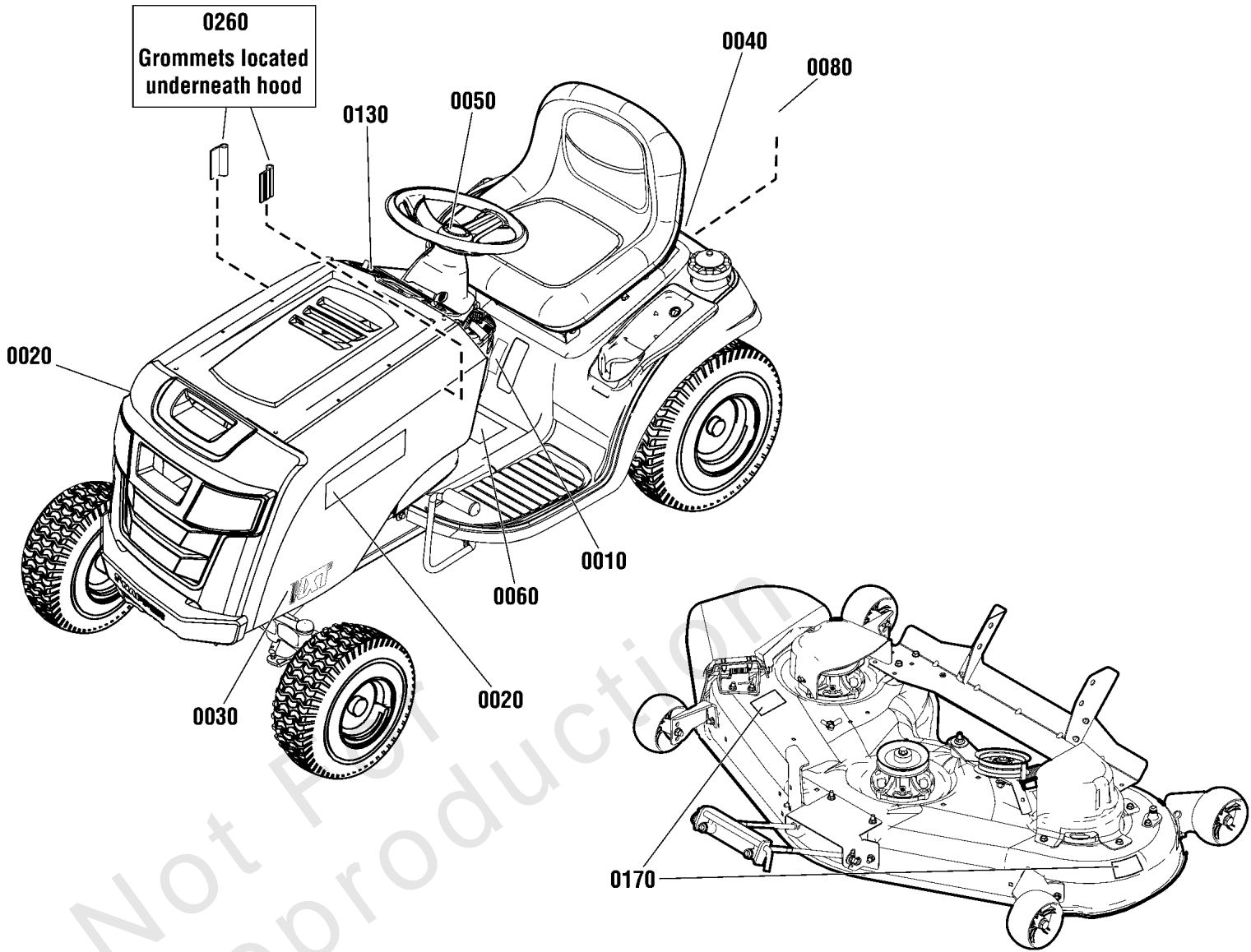

Not For Reproduction

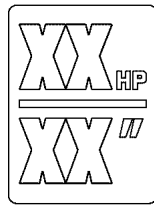

0010



0080



0130

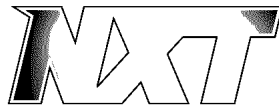

0030



0040

⚠ DANGER
Amputation and thrown objects hazard

- Keep hands and feet away from deck.
- Do not operate mower unless discharge chute or entire grass catcher is in its proper place.

7101665



0050



0020

⚠ DANGER			
<p>Amputation hazard Rotating blades cut off arms and legs. • Stop the mower when children or others are near. • Do not carry riders (especially children) even with the blades off. They may fall off or return for another ride when you are not expecting it. • Look down and behind before and while backing.</p>	<p>Risque d'amputation Les lames en rotation peuvent trancher les bras et les jambes. • Arrêter la tondeuse lorsqu'on est entouré ou des personnes se trouvent à proximité. • Éviter de transporter des enfants ou d'autres personnes pendant que vous travaillez. • Ne pas transporter de passagers (surtout des enfants) même lorsque les lames ne sont pas en mouvement. Cessez de faire un tour ou revenez pour un autre transport à un moment où vous ne voyez y attendre pas.</p>	<p>Roll-over hazard Operating on slopes can cause loss of control and roll-overs. • If you cannot back-up a hill, do not drive on it. • If machine stops while going uphill, stop the blades and back down slowly. • Avoid sudden turns. • Go up and down slopes, not across.</p>	<p>Risque de renversement Si l'angle de conduite sur pentes peut entraîner la perte de contrôle et le renversement de la machine. • Si vous ne pouvez pas remonter une pente en marche arrière, ne conduisez pas devant. • Si la machine s'arrête alors que vous remontez une pente, arrêtez les lames et descendez lentement à l'inclinaison. • Évitez de tourner brusquement. • Prenez les pentes de haut en bas et respectivement de non-traversement.</p>
<p>Fire hazard Gasoline is flammable. Yard debris is combustible. • Allow engine to cool for at least 3 minutes before refueling. • Keep unit cleaned of debris.</p>	<p>Risque d'incendie L'essence est inflammable. Les déchets de jardin sont combustibles. • Laissez refroidir le moteur pendant au moins 3 minutes avant de ravitailler le plein. • Gardez la machine propre de tout débris.</p>	<p>Carbon monoxide hazard The engine emits poisonous carbon monoxide gas. • Avoid running exhaust fumes. • Only operate outdoors.</p>	<p>Risque de monoxyde de carbone Le moteur émet des gaz dangereux et mortels de monoxyde de carbone. • Évitez de respirer les gaz d'échappement. • Ne faites jamais qu'à l'extérieur.</p>
<p>⚠ WARNING Avoid serious injury or death: • Read the operator's manual before using this product. • Know the location and function of all controls. • Keep safety devices (guards, shields, switches, etc.) in place and working. • Remove objects that could be thrown by the blade.</p>		<p>⚠ AVERTISSEMENT Éviter de graves blessures ou la mort. • Lire le manuel de l'utilisateur avant d'utiliser le produit. • Connaître l'emplacement et la fonction de toutes les commandes. • Maintenir en place et en bon état de marche les dispositifs de sécurité (garde-roues, écrans de protection, interrupteurs, etc.). • Enlever les objets qui risquent d'être projetés par les lames.</p>	

⚠ DANGER			
<p>Amputation hazard Rotating blades cut off arms and legs. • Stop the mower when children or others are near. • Do not carry riders (especially children) even with the blades off. They may fall off or return for another ride when you are not expecting it. • Look down and behind before and while backing.</p>	<p>Roll-over hazard Operating on slopes can cause loss of control and roll-overs. • If you cannot back-up a hill, do not drive on it. • If machine stops while going uphill, stop the blades and back down slowly. • Avoid sudden turns. • Go up and down slopes, not across.</p>	<p>Fire hazard Gasoline is flammable. Yard debris is combustible. • Allow engine to cool for at least 3 minutes before refueling. • Keep unit cleaned of debris.</p>	<p>Carbon monoxide hazard The engine emits poisonous carbon monoxide gas. • Avoid inhaling exhaust fumes. • Only operate outdoors.</p>
<p>⚠ WARNING Avoid serious injury or death: • Read the operator's manual before using this product. • Know the location and function of all controls. • Keep safety devices (guards, shields, switches, etc.) in place and working.</p>		<p>• Remove objects that could be thrown by the blade. • Be sure blades and engine are stopped before placing hands or feet near blades. • When leaving machine, shut off, remove key, and set parking brake.</p> <p>• Read the operator's manual before using this product.</p>	

0060

Decals Group - 42", 46" & 52" Deck - Lockup

REF NO	PART NO	QTY	DESCRIPTION
0010	7104808	1	DECAL, Deck, 42"
0010	7101665	1	DECAL, Deck, 46"
0010	7101665	1	DECAL, Deck, 52"
0020	1751632	2	DECAL, Snapper, Turtle
0030	7103964	2	DECAL, Front Cover, NXT Series
0040	7104148	1	DECAL, Logo, Snapper 7-7/8
0050	1739085	1	DECAL, Snapper, Steering Wheel Icon
0060	1734879	1	DECAL, Tunnel Danger Slopes
0060	1739921	1	DECAL, Tunnel Danger Slopes, FR/ENG -(Export Models Only)
0080	1730202	1	DECAL, Transom Tow Release Lever
0130	1739028	2	DECAL, Starter Insert
0170	7101665	2	DECAL, Danger Do Not Operate w/o Deflect

Not For Reproduction

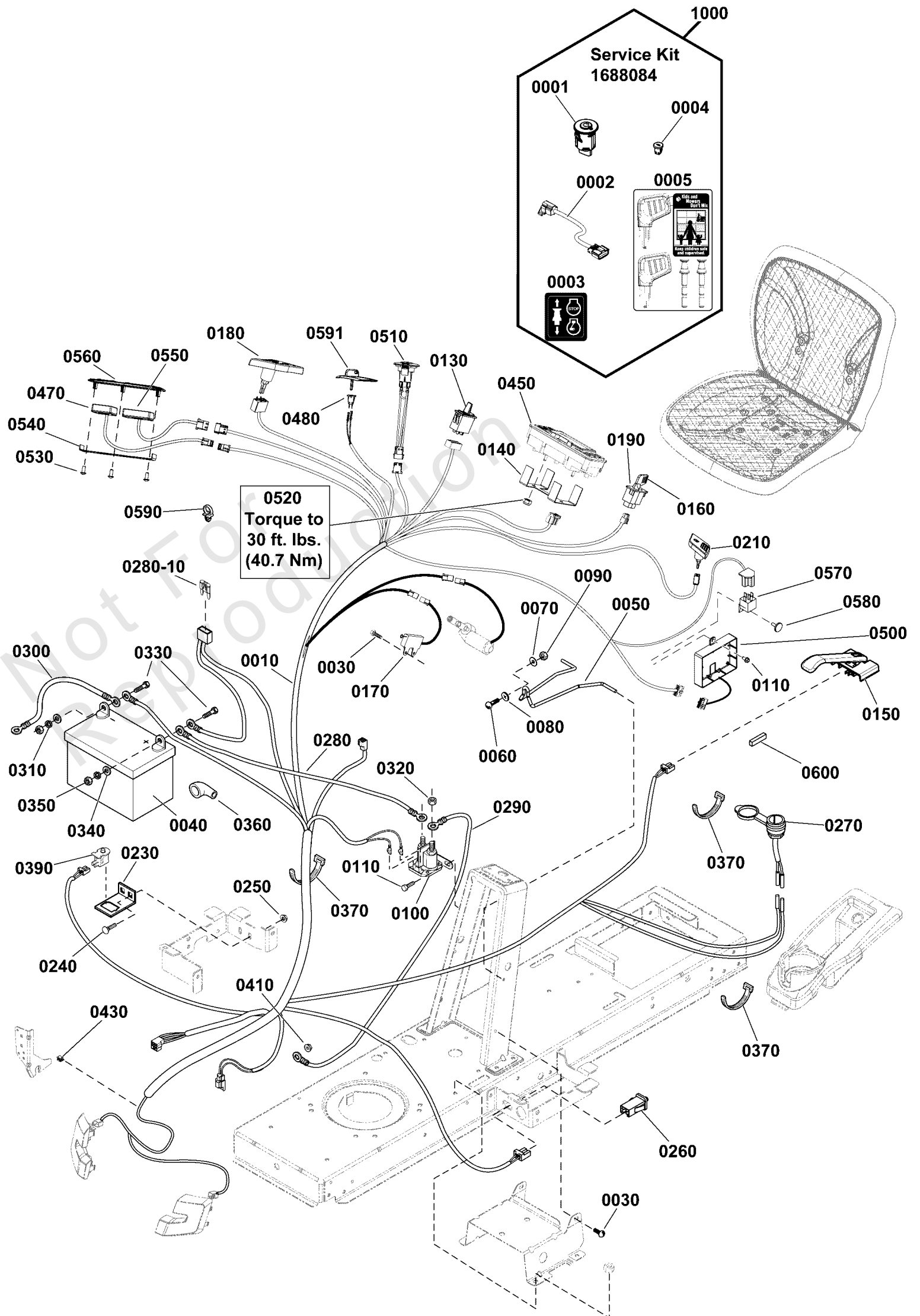

Electrical Group

REF NO	PART NO	QTY	DESCRIPTION
0010	1738984YP	1	WIRING HARNESS
0030	1930601SM	2	CAPSCREW, Hex Washer Head, Taptite, 5/16-18 x 5/8
0040	-----	1	BATTERY, 12 Volt, 230 CCA
0050	1730007SM	1	HOLD DOWN, Battery, 1/4 Dia.
0060	1931318SM	1	BOLT, Carriage, Short Neck, 1/4-20 x 7/8 G5
0070	1960353SM	1	WASHER, 1/4 x 27/32 OD
0080	1960518SM	1	PUSHNUT, 1/4 x 1/2 OD
0090	1920397SM	1	NUT, Hex Lock, ESNA Light, 1/4-20
0100	1728963SM	1	SOLENOID, 12V
0110	1925003SM	3	CAPSCREW, Hex Washer Head, Taptite, 1/4-20 x 1/2
0130	1738381YP	1	SWITCH, Height of Cut
0140	1738961AYP	1	BRACKET, Instrument Panel Mount -(46" & 52" Models Only)
0150	1738015YP	1	SWITCH, Seat
0160	1726557SM	1	KEY, No Mow Module (Yellow)
0170	1738724YP	1	SENSOR, Electric, Height Of Cut
0180	1738982YP	1	SWITCH, PTO
0190	1726556SM	1	SWITCH, Reverse Mow Module
0210	1738983YP	1	SWITCH, Light
0230	1728026ASM	1	SUPPORT, RMO Switch
0240	1931333SM	2	BOLT, Carriage, Short Neck, 5/16-18 x 3/4, GR 5
0250	1931277SM	2	NUT, Hex Flange Whiz Lock Small, 5/16-18
0260	7022886YP	1	SWITCH, DP, NO/NC, Snap-In
0270	7073090SM	1	PLUG, Aux, 12V, (With Cover)
0280	1716549SM	1	CABLE, # 6 x 10 LG, Red Two-Ring Terminals
0280-10	-----	1	* FUSE, 20 Amp -(Refer to Note: *)
0290	1721830SM	1	CABLE, #6 25.0 Lg Red
0300	1713163SM	1	CABLE, # 6 X 26 LG, Two-Ring Terminals
0310	2816964SM	2	LOCKWASHER, Spring, 1/4
0320	2860750SM	2	NUT, Hex Lock, KEPS, 5/16-24
0330	2823341SM	2	CAPSCREW, Hex Head, 1/4-20 x 3/4 G5
0340	2821319SM	2	WASHER, 1/4, .27 ID x .62 OD x .05 THK
0350	2816622SM	2	NUT, HEX 1/4-20 NC-2B YELLOW
0360	1677296SM	1	BOOT, Insulator, Battery Terminal PVC Red
0370	1701011SM	3	TIE, Self Locking, 15" Long
0390	1732004SM	1	SWITCH, Push Button, NO, Black
0410	1960294SM	1	NUT, Hex Flange Whiz Lock Small, 1/4-20
0420	1726557SM	1	KEY, No Mow Module (Yellow) -(Not shown)
0430	2172434SM	1	CLIP, Wire, .390 Dia.
0450	1738021YP	1	PANEL, Instrument -(46" & 52" Models Only)
0470	1738985YP	1	GAGE, Electric, HOC -(42" Models Only)
0480	791944	1	SWITCH, Key
0500	1739020YP	1	PANEL, Control, Push Button Start -(ALL Models except 2690984) (For Replacement Refer To Reference Number 1000)
0500	1752037	1	PANEL, Control -(2690984 Models Only)

Footnotes:

Note: * See your local hardware store for replacement fuses.

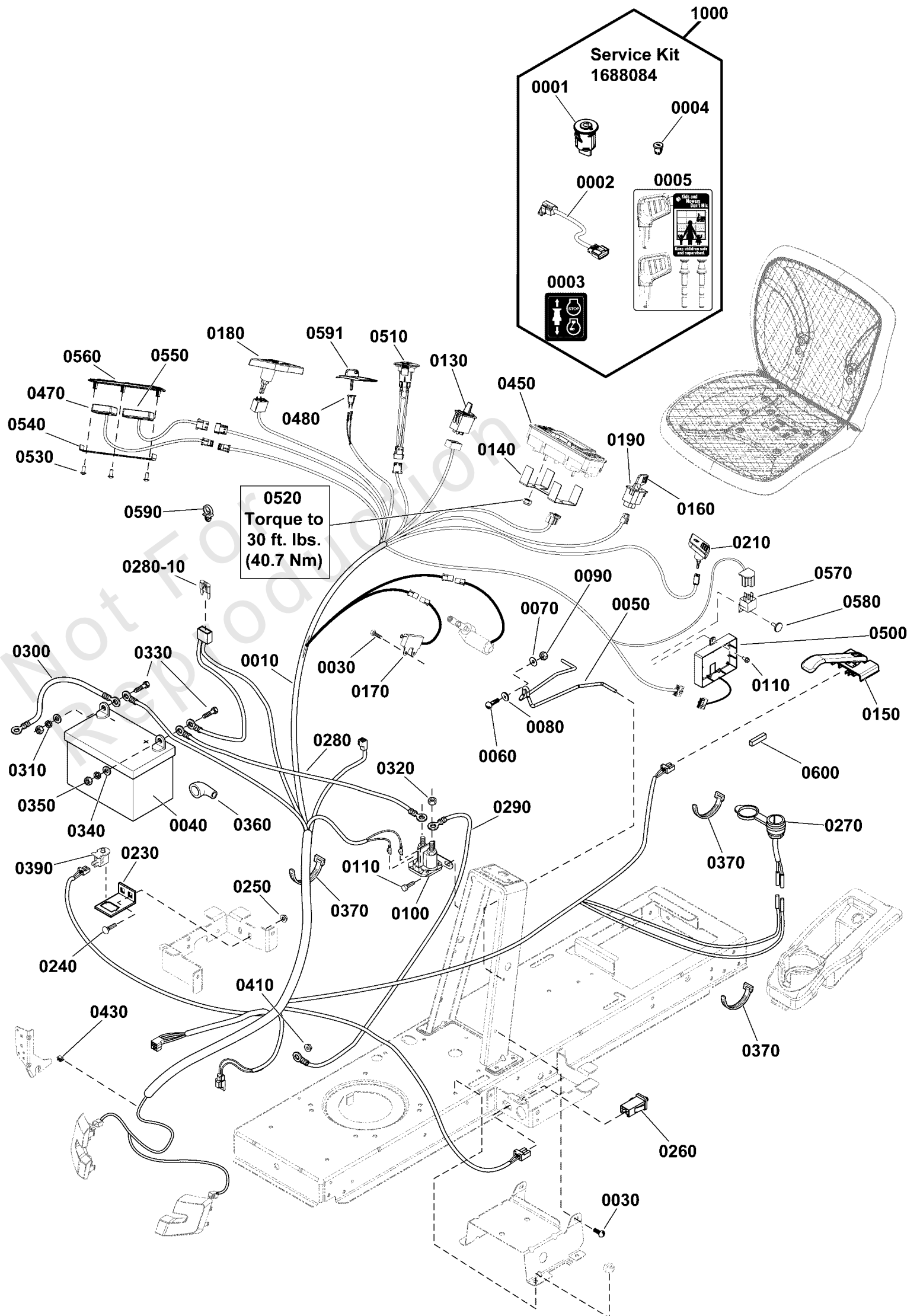

Electrical Group

REF NO	PART NO	QTY	DESCRIPTION
0510	1739277YP	1	SWITCH ASSEMBLY, Push Button Start
0520	67885GS	2	NUT, Nylock, M6-1.0
0530	1739329YP	2	SCREW, PT Thread, 5mm Dia. x 12mm -(42" Models Only)
0540	1739369AYP	1	BRACKET, Instrument Panel
0550	1750212YP	2	METER, Service Indicator -(42" Models Only)
0560	1739307YP	2	BEZEL, Instrument Panel -(42" Models Only)
0570	1726829SM	1	RELAY(S)
0580	1704351SM	1	FASTENER, Panel, 3/4 OD x 11/16
0590	1730268SM	1	CLIP, Hose, 1/2 Dia., Push In
0591	1738614YP	1	STARTER INSERT
0600	1750296YP	1	FOAM STRIP
0650	1734025	1	WIRES & CONNECTOR ASSEMBLY -(46" CE/Export Models Only)
0660	1752222	1	HARNESS, Jumper, All Condition Shutdown -(46" CE/Export Models Only)
1000	1688084	1	KIT, IGNITION -(Includes Reference Numbers 0001, 0002, 0003, 0004, 0005)
0001	84003613	1	SWITCH ASSEMBLY, Push Button Start
0002	84003694	1	ADAPTER, Harness
0003	84003695	1	DECAL, KEY FOB, CONTROL
0004	282640YP	1	PLUG, Hole
0005	84003869	1	BLISTER PACK

Footnotes:

Note: * See your local hardware store for replacement fuses.

Engine Group - 22, 23, 25, 26 & 27HP Briggs & Stratton EFM Twin Professional Series

Note: Unless noted otherwise, use the standard torque specifications

Mfg. No: 2691023-00

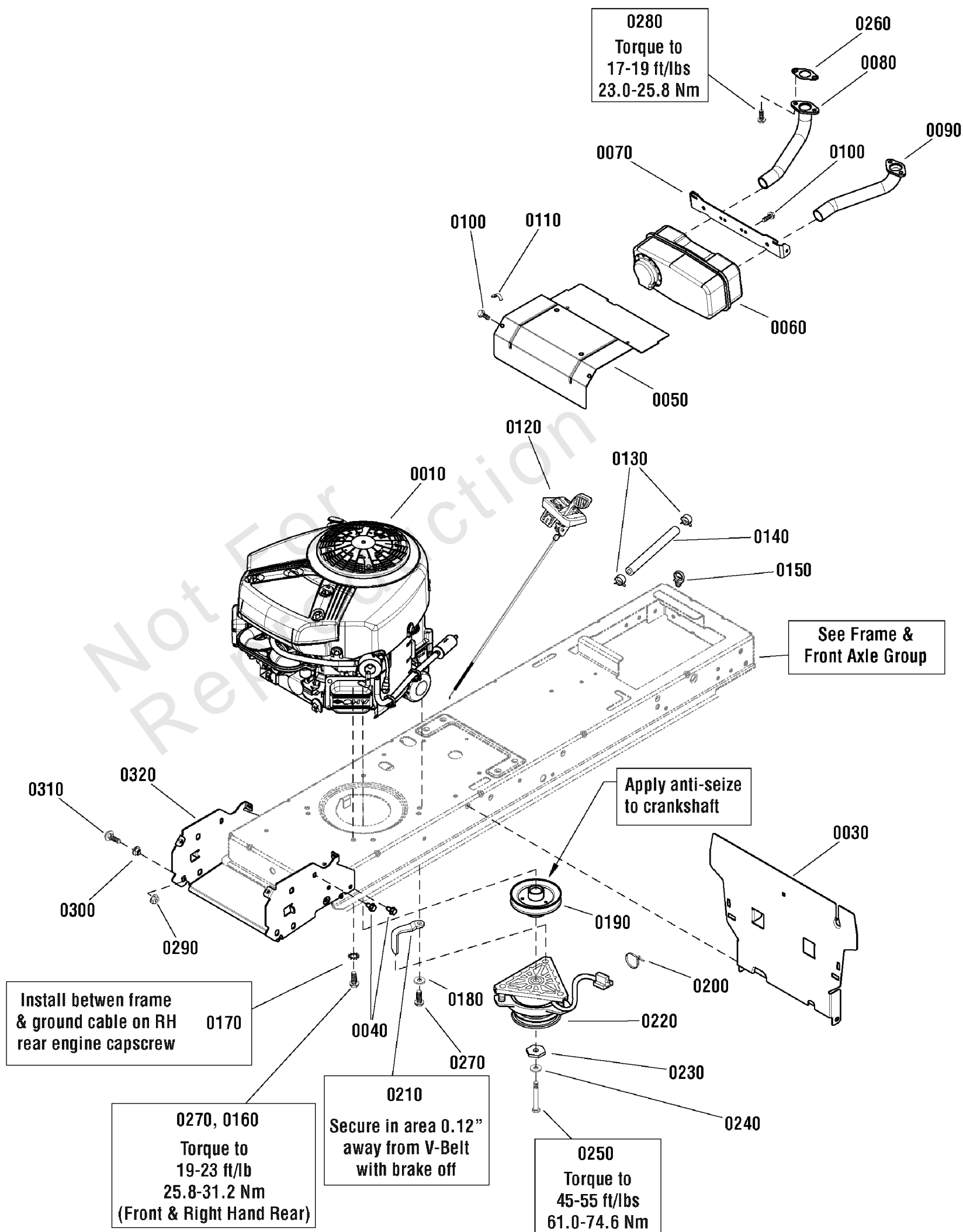

Engine Group - 22, 23, 25, 26 & 27HP Briggs & Stratton EFM Twin Professional Series

REF NO	PART NO	QTY	DESCRIPTION
0010	31Q677-0121-B1	1	* ENGINE, 19.5HP B&S EFM Twin Professional Series, Model 31Q677-0121-B1 -(Used on 42" models)
0010	40H777-0150-G5	1	* ENGINE, 22HP B&S EFM Twin Professional Series, Model 40H777-0150-G5 -(Used on 42" models)
0010	44L777-0139-B1	1	* ENGINE, 23HP B&S EFM Twin Professional Series, Model 44L777-0139-B1 -(Used on 46" models)
0010	44L777-5132-B1	1	* ENGINE, 23HP B&S EFM Twin Professional Series, Model 44L777-5132-B1 -(Used on 46" models)
0010	44L777-5139-G5	1	* ENGINE, 23HP B&S EFM Twin Professional Series, Model 44L777-5139-G5 -(Used on 46" models)
0010	44S977-0008-G1	1	* ENGINE, 25HP B&S EFM Twin Professional Series, Model 44S977-0008-G1 -(Used on 48" models)
0010	44P777-0181-G5	1	* ENGINE, 26HP B&S EFM Twin Professional Series, Model 44P777-0181-G5 -(Used on 52" models)
0010	44L777-0132-B1	1	* ENGINE, 27HP B&S EFM Twin Professional Series, Model 44L777-0132-B1 -(Used on 52" models)
0010	44Q777-0138-B1	1	* ENGINE, 27HP B&S EFM Twin Professional Series, Model 44Q777-0138-B1 -(Used on 52" models)
0030	1738380A	1	HEAT SHIELD, Engine
0040	1930601	8	CAPSCREW, Hex Washer Head, Taptite, 5/16-18 x 5/8
0050	1727997A	1	HEAT SHIELD, Engine, Twin
0060	1727994	1	MUFFLER, Briggs & Stratton Twin
0070	1727976A	1	SUPPORT, Muffler
0080	1727979	1	PIPE, Exhaust, Flanged, R.H, 1 1/8 OD
0090	1727980	1	PIPE, Exhaust, Flanged, L.H, 1 1/8 OD
0100	1925003	4	CAPSCREW, Hex Washer Head, Taptite, 1/4-20 x 1/2
0110	2834683	1	CLIP, Wire, 1/8 Dia.
0120	1738793	1	CONTROL, Throttle Only
0130	93053	2	CLAMP, Hose Band
0140	1734993	1	HOSE, Fuel, 1/4 ID x 1/2 OD, 55" Long, Low Perm.
0150	1730268	1	CLIP, Hose, 1/2 Dia.
0160	2827187	2	CAPSCREW, Hex Washer Head, Taptite, 3/8-16 x 1
0170	2820427	1	LOCKWASHER, External Tooth, 3/8
0180	1924940	1	WASHER, 3/8 x 7/8 OD
0190	1732576	1	PULLEY & HUB ASSEMBLY, Engine
0200	1701011	1	TIE, Self Locking, 15" Long
0210	1737421A	1	GUIDE, Belt, Long
0220	1736105	1	CLUTCH, Electric, OGURA
0230	1708264	1	WASHER, Hex, 7/16, ID x 1-1/2
0240	1918199	1	LOCKWSHER, Spring, 7/16
0250	1960649	1	CAPSCREW, Hex Head, 7/16-20 x 3-1/2, G5
0260	1731214	2	GASKET, Exhaust
0270	2828635	2	CAPSCREW, Hex Washer Head, Taptite, 3/8-16 x 1-1/4
0280	94480	4	CAPSCREW, Hex, Lock Washer, 5/16-18 x 7/8
0290	1931277	2	NUT, Hex Flange, Whiz Lock, 5/16-18
0300	1728086	2	PIVOT, Hood
0310	1931335	2	BOLT, Carriage, Short Neck, 5/16-18 x 1
0320	1738265A	1	SUPPORT, Muffler & Hood Pivot

Footnotes:

Note* To verify your specific engine model, please reference the ID Tag located on your engine. See your local Briggs & Stratton distributor for parts and service.

Note* See your local Briggs & Stratton distributor for parts and service.

Frame & Front Axle Group

Note: Unless noted otherwise, use the standard torque specifications

Mfg. No: 2691023-00

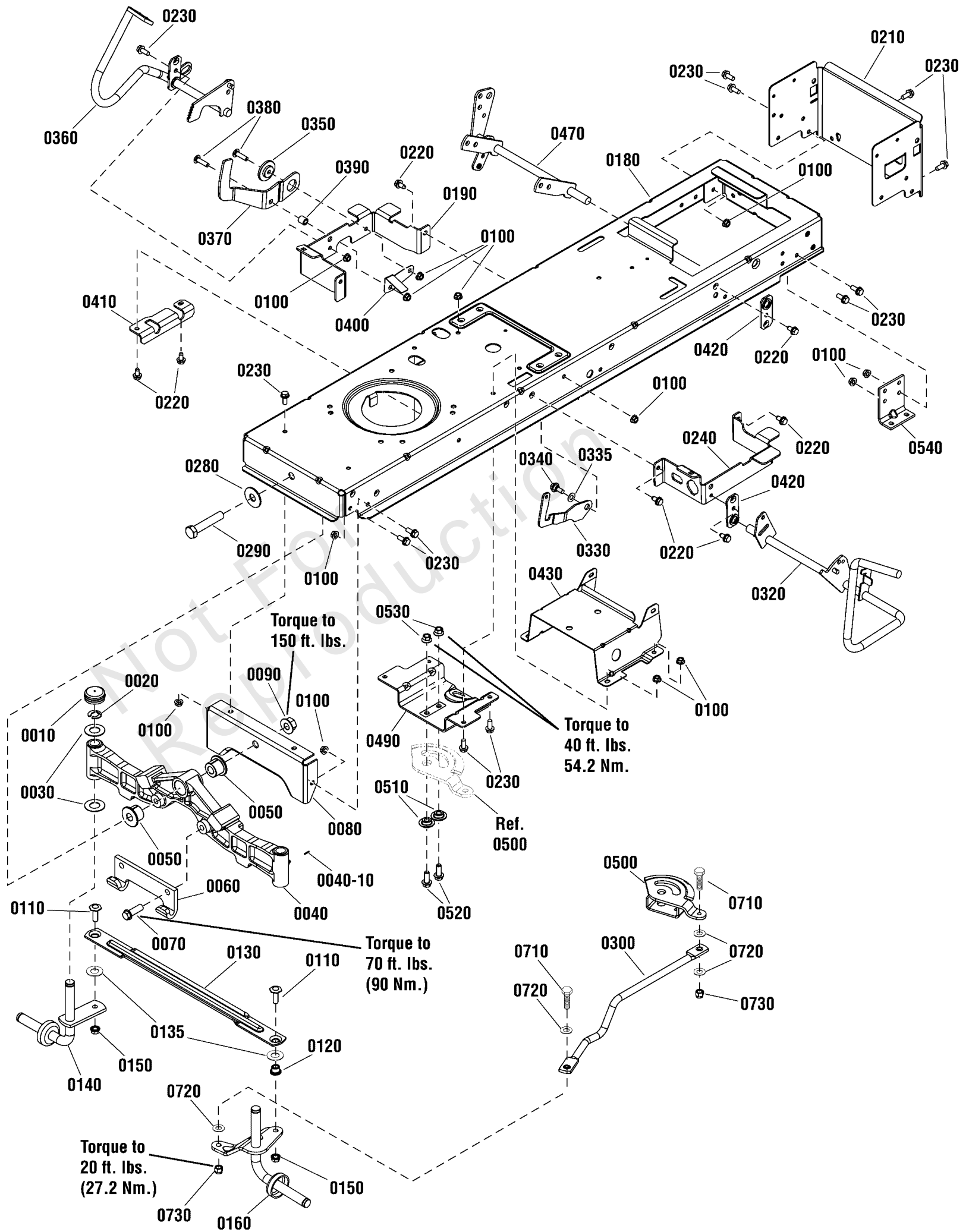

Frame & Front Axle Group

REF NO	PART NO	QTY	DESCRIPTION
0010	1734135	2	CAP, Hub, 1.48 ID x .62 Long
0020	1611710	2	RING, Klipring, 3/4 Dia.
0030	2860183	4	WASHER, 3/4 x 1-5/8 OD x 1/16 Thick
0040	1728018	1	AXLE, Front -(Includes Ref. No. 0040-10)
0040-10	1704314	3	FITTING, Zerk
0050	1730186	2	BUSHING, Axle Pivot
0060	1721918	1	HOOK, Mower, Hitch
0070	1960652	2	CAPSCREW, Hex, Whiz Lock, 7/16-14 x 1-1/2
0080	1727902	1	PLATE, Axle Support
0090	2860646	1	NUT, Hex Flange, Two Way, 5/8-11
0100	1931277	25	NUT, Hex Flange, Whiz Lock, 5/16-18
0110	1960032	2	CAPSCREW, Hex Head, 3/8-16 x 1-1/4, G5
0120	1731912	2	BUSHING, 3/8 ID x 5/8 OD x 9/16 Long
0130	1751964	1	TIE ROD, Flat
0135	1960703	2	WASHER, Flat, 5/8
0140	1727872	1	WHEEL SPINDLE ASSEMBLY, R.H.
0150	1930645	2	NUT, Hex Flange, Two Way, Locking, 3/8-16
0160	1751922	1	WHEEL SPINDLE ASSEMBLY, L.H.
0180	1738937	1	FRAME
0190	1727904	1	SUPPORT, Front Footrest, R.H.
0210	1738229	1	SUPPORT, Rear Frame
0220	1930601	9	CAPSCREW, Hex Washer Head, Taptite, 5/16-18 x 5/8
0230	1930591	21	CAPSCREW, Hex, Whiz Lock, 5/16-18 x 3/4
0240	1727905	1	SUPPORT, Front Footrest, L.H.
0280	1960035	1	WASHER, 5/8 x 1-3/4 OD
0290	2860744	1	CAPSCREW, Hex Head, 5/8-11 x 3-1/4, G5
0300	1738051	1	LINK, Drag (with Bearing), 5/16
0320	1736404	1	PEDAL ASSEMBLY, Brake
0330	1735595	1	LATCH, Brake Lock
0340	1729576	1	BOLT, Shoulder, 5/16-18 x 15/32, G5
0350	1727935	1	SPACER, Pivot, 11/32 ID 1-3/4 OD
0360	1736714	1	PEDAL ASSEMBLY, Forward
0370	1727246	1	PEDAL, Reverse
0380	1960223	2	BOLT, Carriage, 5/16-18 x 1-1/4, G5
0390	1728024	1	SPACER, Foot Pedal
0400	1728025	1	ACTUATOR, RMO Switch
0410	1727909	1	BRACKET, Pedal Pivot
0420	1727911	2	PLATE, Bearing
0430	1727282	1	SUPPORT, Battery
0470	1737957	1	LIFT SHAFT ASSEMBLY
0490	1727940	1	BRACKET, Sector Support
0500	1751110	1	GEAR, Steering
0510	1728122	2	SPACER, Sector Gear, 3/8 ID x 1-1/4 OD
0520	1934654	2	CAPSCREW, Hex, Whiz Lock, 3/8-16 x 1
0530	1931211	2	NUT, Hex Flange, Whiz Lock, 3/8-16
0540	1727903	2	SUPPORT, Transmission
0710	1921977	2	CAPSCREW, Hex Head, 5/16-18 x 1-1/4, G5
0720	703302	2	WASHER, Flat, 5/16
0730	1935048	2	NUT, Hex Flange, Two Way Lock, 5/16-18

Hood, Grille & Dash Group - Embossed

Note: Unless noted otherwise, use the standard torque specifications

Mfg. No: 2691023-00

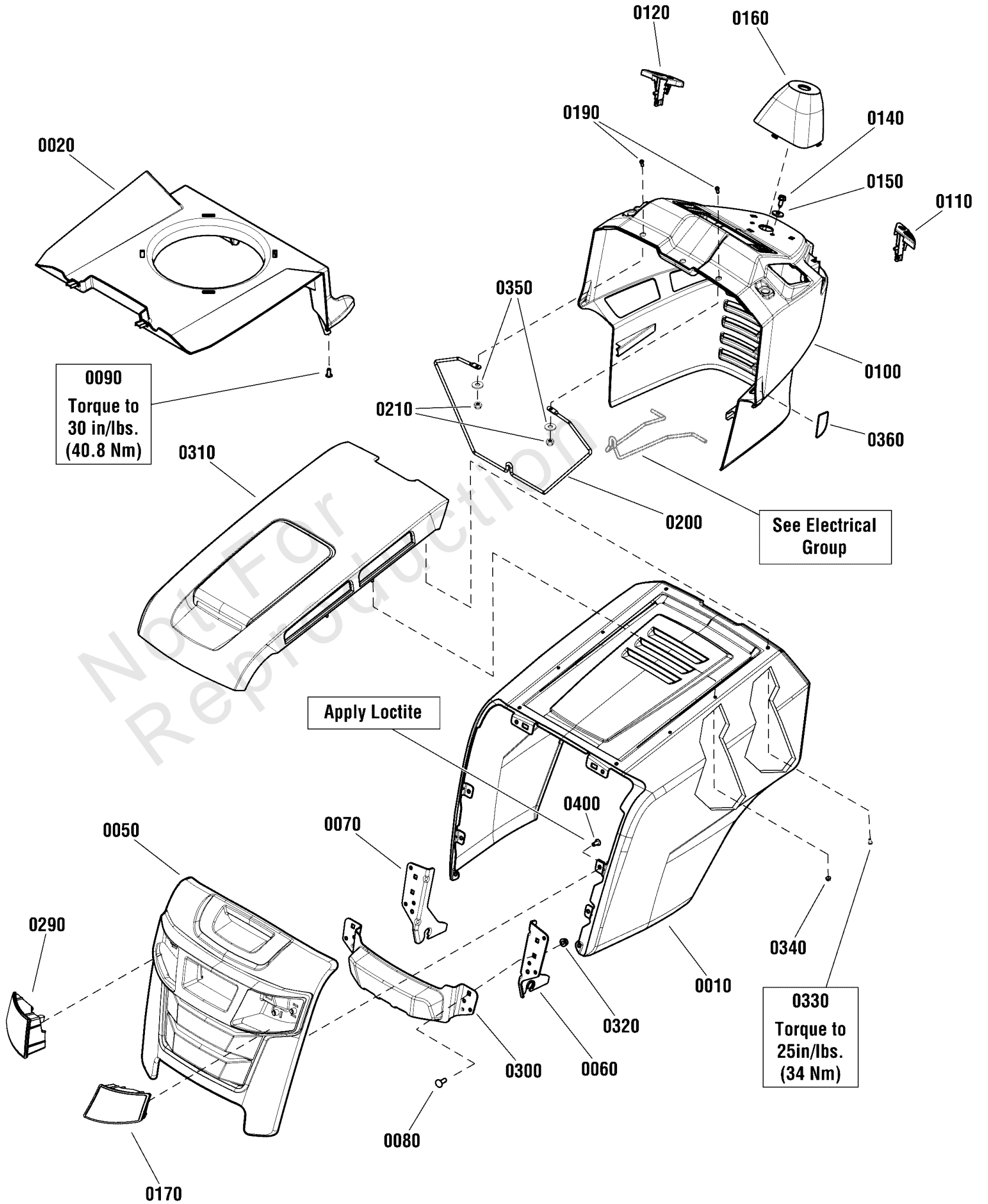

Hood, Grille & Dash Group - Embossed

REF NO	PART NO	QTY	DESCRIPTION
0010	1752930D	1	HOOD, One Piece
0020	1738734	1	AIR DUCT
0050	1752929	1	GRILLE, Front
0051	1758731YP	2	INSULATION, Thermal 2.0" X 12.5" (Not Shown)
0060	1738566A	1	HINGE, Hood, LH
0070	1738565A	1	HINGE, Hood, RH
0080	7091714	2	BOLT, Carriage, Short Neck, 5/16-18 x 1, G5
0090	1739220	2	SCREW, PT Thread, 7mm Dia. x 16mm
0100	1753166	1	DASH
0110	1738789	1	KNOB, Parking Brake
0120	1738788	1	KNOB, Cruise
0140	1664847	2	SCREW, Hex Washer Head Taptite 5/16-18 x 3/4
0150	1919381	2	WASHER, 5/16 x 1OD
0160	1738790	1	COVER, Steering Shaft, Black
0170	1753171	1	HEADLIGHT, Led, LH
0190	1739942	2	SCREW, Pan Head Phillips #10-24 x 7/8
0200	1738964	1	ROD, Dash Support, 1/4 Dia., 10" Lg
0210	1933896	2	NUT, Hex Lock
0290	1753172	1	HEADLIGHT, Led, RH
0300	1753170BM	1	BUMPER ASSEMBLY
0320	1960686	2	NUT, Hex Flange, ESNA, 5/16-18
0310	1752925	1	TRIM, Hood
0330	1739329	4	SCREW, Washer Head, 5mm x 12mm Long
0340	189164	4	PALNUT, 3/16
0350	1960353	2	WASHER, 1/4
0360	1753895	1	TRIM, Protective
0400	1754203	8	SCREW, PT Thread, 7mm Dia. x 16mm

Lift Group - Electric

Note: Unless noted otherwise, use the standard torque specifications

Mfg. No: 2691023-00

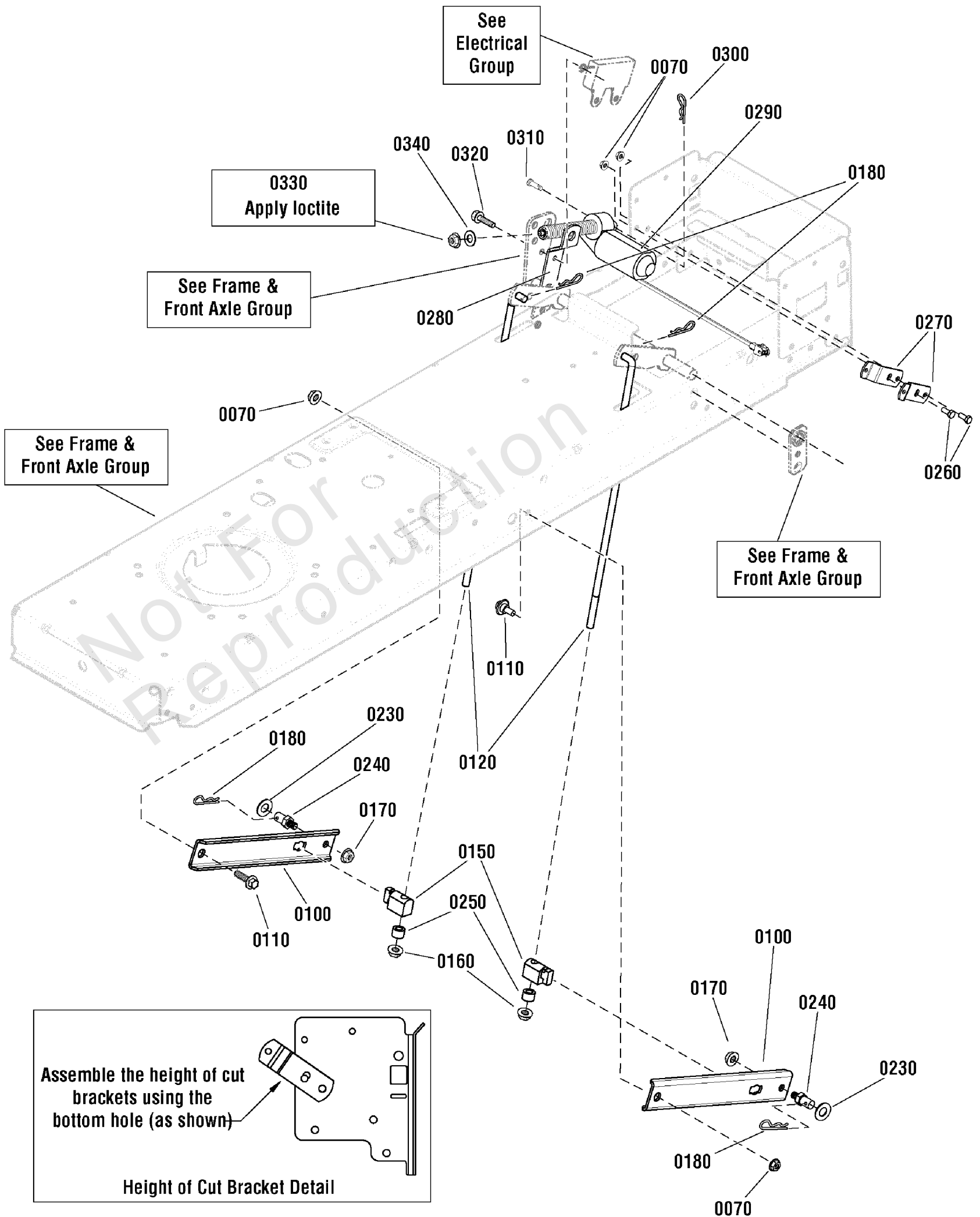

Lift Group - Electric

REF NO	PART NO	QTY	DESCRIPTION
0070	1931277	4	NUT,HexFlange,WhizLock,5/16-18
0100	1731417A	2	ARM,RearLift
0110	1732426	2	BOLT,Shoulder,5/16-18x9/16
0120	1727955	2	ROD,Lift,Lower,3/8x10Long
0150	1731894	2	TRUNNION
0160	1960687	2	NUT,HexFlange,ESNA,3/8-16
0170	1931211	2	NUT,HexFlange,WhizLock,3/8-16
0180	1960074	4	CLIP,HairPin,1-5/8
0230	1960170	2	WASHER,1/2x1OD
0240	721221	2	PIN,Threaded,Shoulder,3/8-16x1-7/16Long
0250	1666294	2	SPACER,3/8IDx7/16Long
0260	1921332	2	CAPSCREW,HexHead,5/16-18x3/4,G5
0270	1737856A	2	SUPPORT,Electric,Lift
0280	1737859A	1	SUPPORT,Electric,Lift
0290	1738294	1	MOTOR,Electric,MiniEHOC,Peerless
0300	1722460	1	PIN,Quick,1-3/16Long
0310	1668344	1	PIN,Shear,1/4ID.X1-3/4Long
0320	1960373	1	CAPSCREW,HexWasherHead,Taptite,5/16-18x1
0330	1960757	1	NUT,Hex,1/4-20L.H.Thread
0340	1921319	1	WASHER,1/4,x5/8OD

Seat Deck & Fuel Tank Group - EVAP Compliant (22GT, 23GT, 25GT, 26GT & 27GT)

Note: Unless noted otherwise, use the standard torque specifications

Mfg. No: 2691023-00

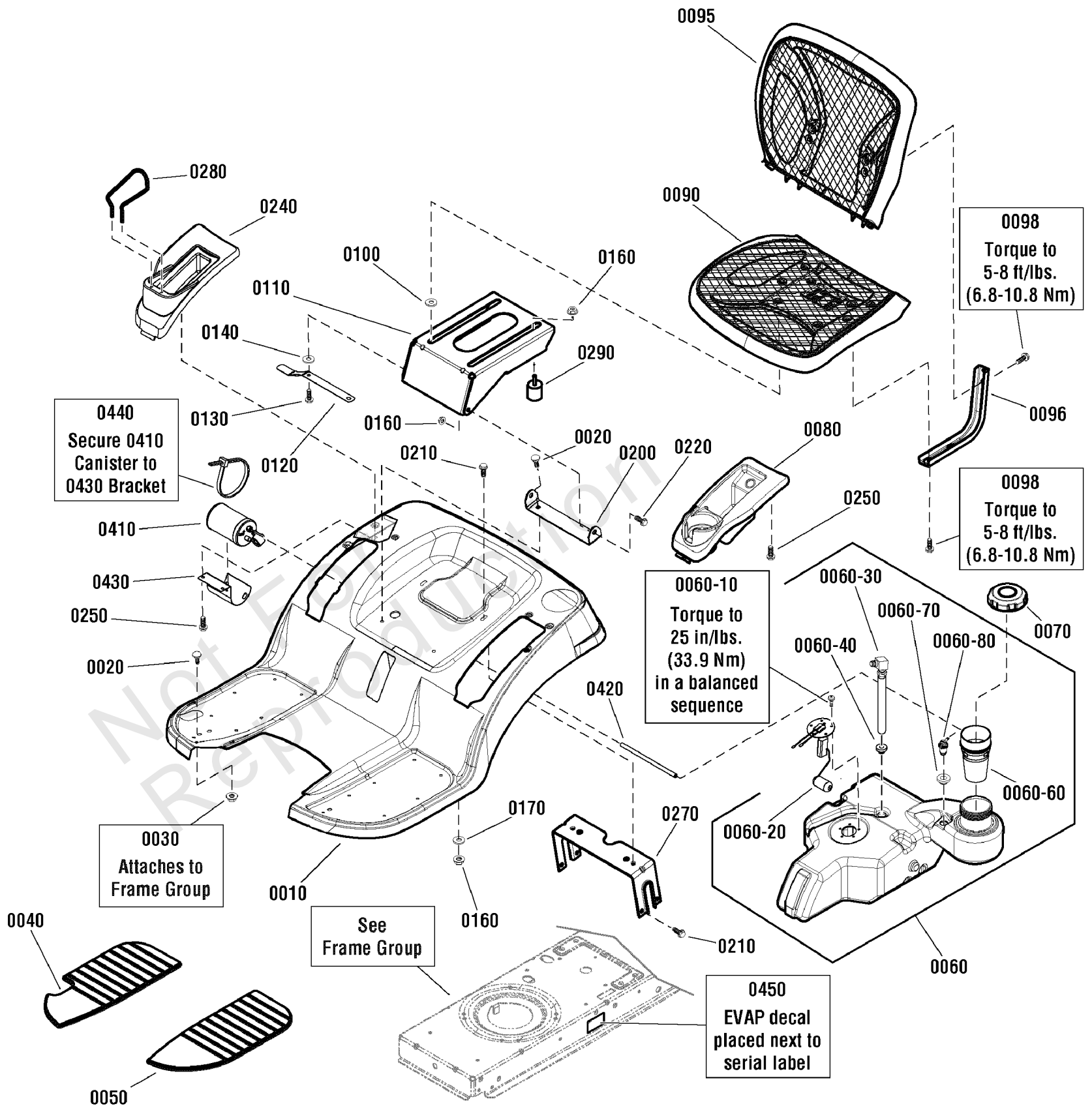

Seat Deck & Fuel Tank Group - EVAP Compliant (22GT, 23GT, 25GT, 26GT & 27GT)

REF NO	PART NO	QTY	DESCRIPTION
0010	1727264D	1	DECK, Seat
0020	1931333	4	BOLT, Carriage, 5/16-18 x 3/4, G5
0030	1931277	2	NUT, Hex Flange, Whiz Lock, 5/16-18
0040	1728007	1	PAD, Footrest R.H.
0050	1728006	1	PAD, Footrest L.H.
0060	1738931	1	TANK, Fuel (with Fuel Sender) -(52", 48" & 46" Models Only)
0060	1738932	1	TANK, Fuel -(42" Models Only)
0060-10	2860665	5	SCREW, Pan Head, Torx, 10-32 x 1/2 -(52", 48" & 46" Models Only)
0060-20	1737523	1	SENDER, Fuel Tank -(52", 48" & 46" Models Only)
0060-30	1736609	1	FITTING & HOSE ASSEMBLY, Fuel Tank
0060-40	1654930	1	BUSHING, Fuel Tank
0060-50	1751624	1	FILLER NECK (Not Shown)
0070	1739760	1	CAP, Fuel, Vented
0080	1739015	1	POD, L.H.
0090	1738013	1	SEAT, Mesh Bottom
0095	1753182	1	SEAT, Mesh, Low Back
0095	1738014	1	SEAT, Mesh, Back -(46" Twin Models Only)
0096	1737848A	2	SUPPORT, Mesh Seat
0098	1930591	8	CAPSCREW, Hex, Whiz Lock, 5/16-18 x 3/4
0100	1731300	4	SPACER, 5/16 ID x 1-1/4 OD
0110	1727265A	1	SUPPORT, Seat
0120	1727268	1	LATCH, Seat
0130	1960667	4	CAPSCREW, Hex, Whiz Lock, 5/16-18 x 1
0140	1919381	4	WASHER, 5/16 x 1 OD
0160	1960686	6	NUT, Hex Flange, ESNA, 5/16-18
0170	1709256	2	WASHER, Spring, 5/16 ID x 1-1/4 OD
0200	1727266A	1	PIVOT, Seat
0210	1930601	6	CAPSCREW, Hex Washer Head, Taptite, 5/16-18 x 5/8
0220	1729576	2	BOLT, Shoulder, 5/16-18 x 15/32, G5
0240	1738795	1	POD, Electric, HOC, R.H.
0250	1960536	6	CAPSCREW, Hex Washer Head, 1/4 x 1/2
0270	1731310A	1	SUPPORT, Seat Deck
0280	1739276	1	ROD, Bottle Retainer
0290	5022612	2	BUMPER, Rubber, 5/16-18
0410	1751599	1	CANISTER, Carbon, 300CC
0420	1751715	1	HOSE, Vapor, 5mm
0440	1701011	1	TIE, Self Locking, 15" Lg
0450	1753994	1	DECAL, EVAP

Steering Group

Note: Unless noted otherwise, use the standard torque specifications

Mfg. No: 2691023-00

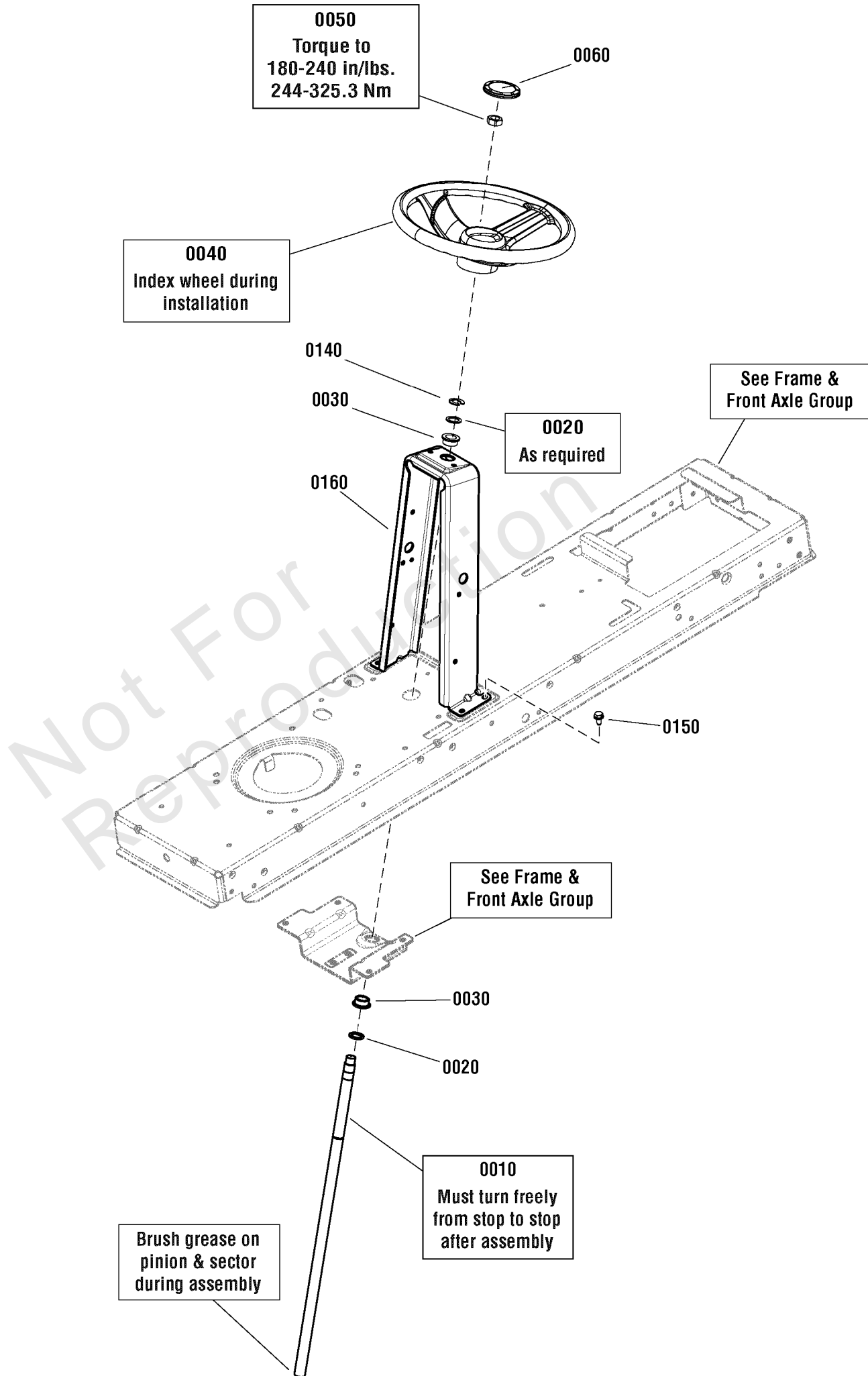

Steering Group

REF NO	PART NO	QTY	DESCRIPTION
0010	1727813SM	1	SHAFT, Steering Gear & Spline
0020	703151	2	WASHER, .766 ID X 1.06 OD X .07
0030	1729665SM	2	BUSHING, Steering, 3/4 ID
0040	7078088YP	1	STEERING WHEEL, UV-2
0050	1960576SM	1	NUT, Hex Lock, ESNA Light, 5/8-18 -(CE/Export Only)
0060	1725024SM	1	CAP, Steering Wheel
0140	1611710SM	1	RING, Klipring, 3/4 Dia.
0150	1930601SM	4	CAPSCREW, Hex Washer Head, Taptite, 5/16-18 x 5/8
0160	1738935AYP	1	TOWER

Not For Reproduction

Transmission Group

Note: Unless noted otherwise, use the standard torque specifications

Mfg. No: 2691023-00

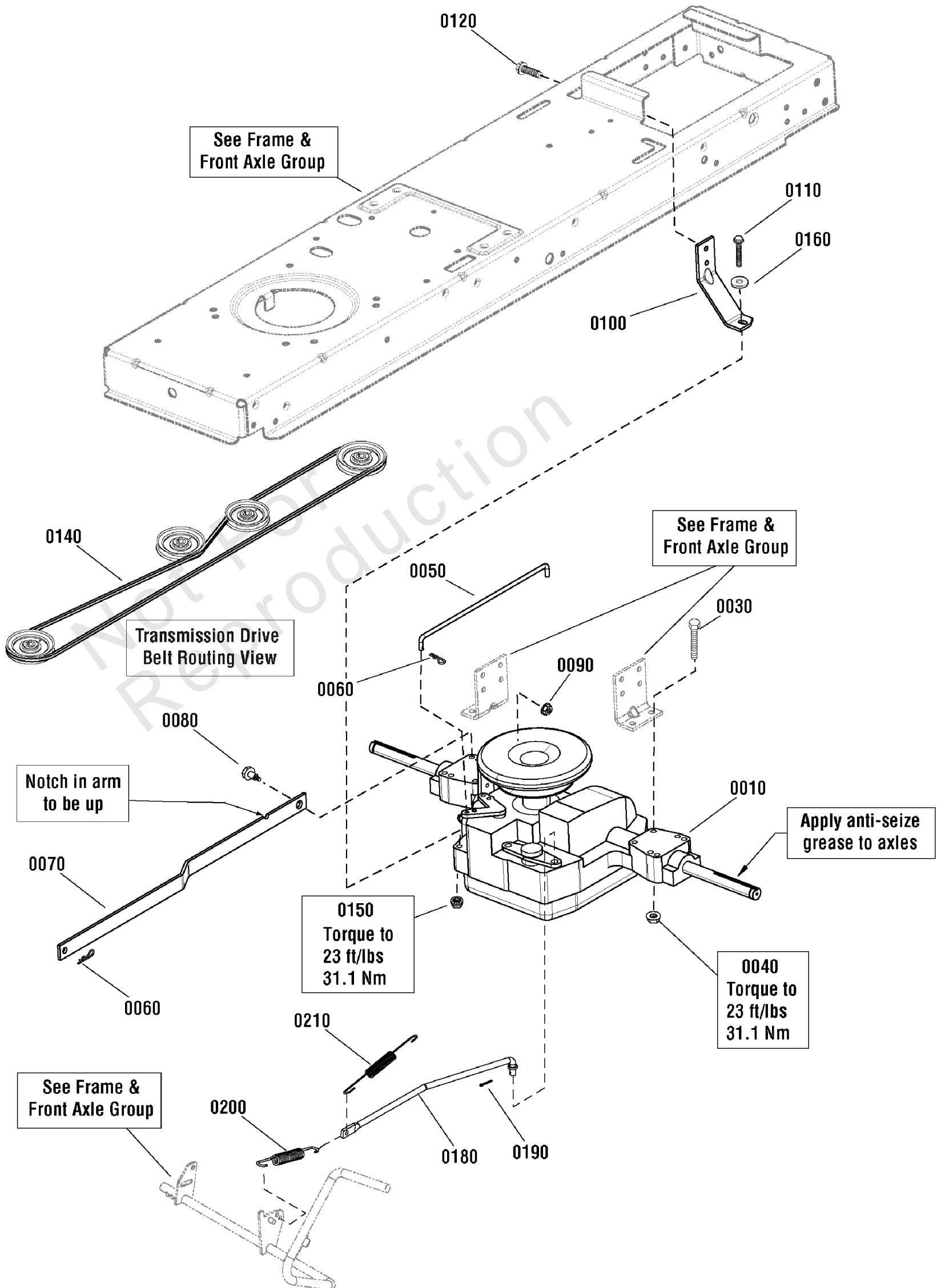

Transmission Group

REF NO	PART NO	QTY	DESCRIPTION
0010	1729589	1	TRANSMISSION ASSEMBLY, K46BL -(48" & 52" Models Only)
0010	1729588	1	TRANSMISSION ASSEMBLY, K46BP -(42" & 46" Models Only)
0030	1960586	4	SCREW, Hex Flange Wiz Lock, 5/16-18 x 2-1/2
0040	1931277	4	NUT, Hex Flange Wiz Lock, 5/16-18
0050	1728120	1	ROD, 1/4 Dia. X 11-7/16 Lg
0060	1722460	2	PIN, Quick, 1-3/16
0070	1727258A	1	ARM, Control
0080	1732426	1	BOLT, Shoulder, 5/16-18 x 9/16
0090	1935048	1	NUT, Hex Flange Two Way Locking, 5/16-18
0100	1728043A	1	STRAP, Torque
0110	1922127	1	CAPSCREW, Hex Head, 5/16-18 x 1-3/4, G5
0120	1664847	1	SCREW, Hex Washr Head, Taptite, 5/16-18 x 3/4
0140	1728008	1	V-BELT, HA, 89-1/4 Lg
0150	1960686	1	NUT, Hex Flange, ESNA, 5/16-18
0160	1919381	1	WASHER, 5/16 x 1OD
0180	1727253	1	ROD, 3/8 Dia x 15-7/64 Lg
0190	1918447	1	COTTER PIN, 15/16 x 3/4
0200	1731262	1	SPRING, Extension, 5-3/8
0210	1721995	1	SPRING, Extension, 5/8 OD x 6-5/8 Lg

Not For Production

Transmission SERVICE PARTS - Tuff Torq K46BP

Note: Unless noted otherwise, use the standard torque specifications

Mfg. No: 2691023-00

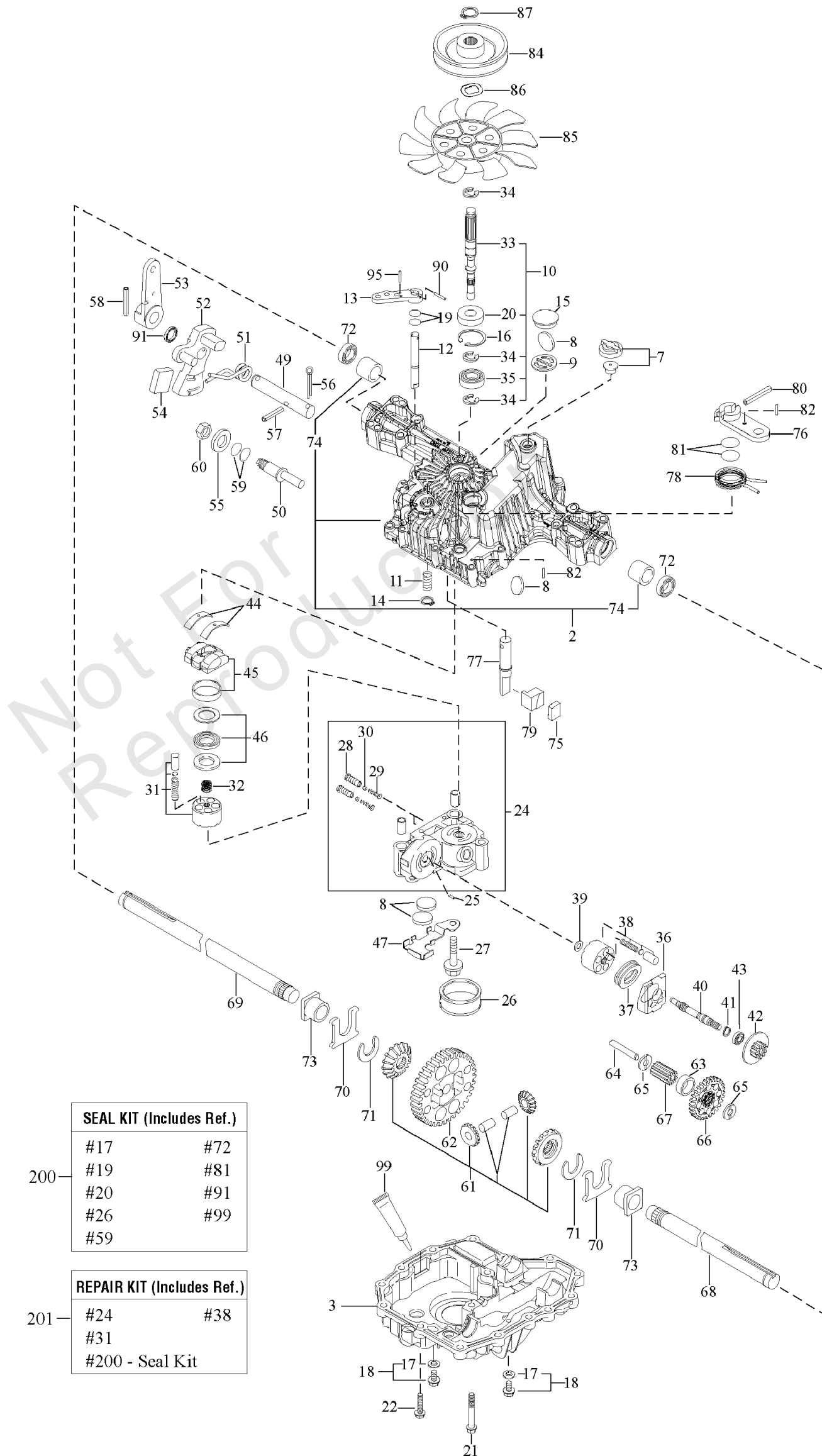

SEAL KIT (Includes Ref.)	
#17	#72
#19	#81
#20	#91
#26	#99
#59	

200

REPAIR KIT (Includes Ref.)	
#24	#38
#31	
#200 - Seal Kit	

201

Transmission SERVICE PARTS - Tuff Torq K46BP

REF NO	PART NO	QTY	DESCRIPTION
1	1729588		*TRANSMISSION, Tuff Torq K46BP
2	-----		*KIT, Upper Case
3	-----		*LOWER CASE
7	1718052		VENT VALVE 15
8	1724279		MAGNET
9	-----		*MAGNET HOLDER
10	-----		*PUMP SHAFT/BEARING KIT
11	-----		*SPRING 25
12	1724281		BYPASS SHAFT A
13	1720418		LEVER, Bypass
14	1718061		RING, Snap, 10
15	1724282		SEALING CAP 30
16	1708650		RING, Snap, C 35
17	1724323		SEAL WASHER 8
18	-----		*KIT, Drain Bolt
21	-----		*SCREW, Tapping, 8 * 55
22	1707789		SCREW, Tapping, 8 * 30
24	-----		*CENTER CASE E W/BALL IDS SERVICE KIT
25	1718070		PIN, 3 * 9.8
26	-----		*FILTER 105
27	1720805		BOLT, 10 * 75
28	-----		*IDS VALVE 1.0
29	1724287		IDS SPRING
30	-----		*BALL, 3/16
31	-----		*KIT, Cylinder Block (Pump)
32	1724290		SPRING
33	1739892		PUMP SHAFT
34	1718076		E-RING 15
35	1708673		BEARING, 6202C3
36	1718077		MOTOR HOUSING
37	-----		*THRUST BEARING 51106
38	1718079		KIT, Cylinder Block
39	1718084		WASHER, 12 * 24 * 1
40	1724943		MOTOR SHAFT
41	1708672		RING, Snap, S15
42	1724294		BRAKE DISC/MOTOR GEAR (11T)
43	-----		*BEARING, 6202 RSR C3
44	1718089		THRUST METAL
45	-----		*SWASH PLATE CMP
46	1718086		THRUST BEARING K81105
49	-----		*CONTROL SHAFT
50	-----		*FULCRUM
51	-----		*SPRING, Torsion
52	-----		*CONTROL ARM A
53	1724347		CONTROL LEVER C
54	-----		*JERKY PLATE
55	1708689		WASHER, 12
56	1724349		COTTER PIN, 1/8 * 3/4

Footnotes:

*Note: See your local authorized dealership for Tuff Torq parts and warranty or contact Tuff Torq at www.tufftorqservices.com (U.S. 1-866-572-3441; Int'l 01-423-585-1977)

Transmission SERVICE PARTS - Tuff Torq K46BP

Note: Unless noted otherwise, use the standard torque specifications

Mfg. No: 2691023-00

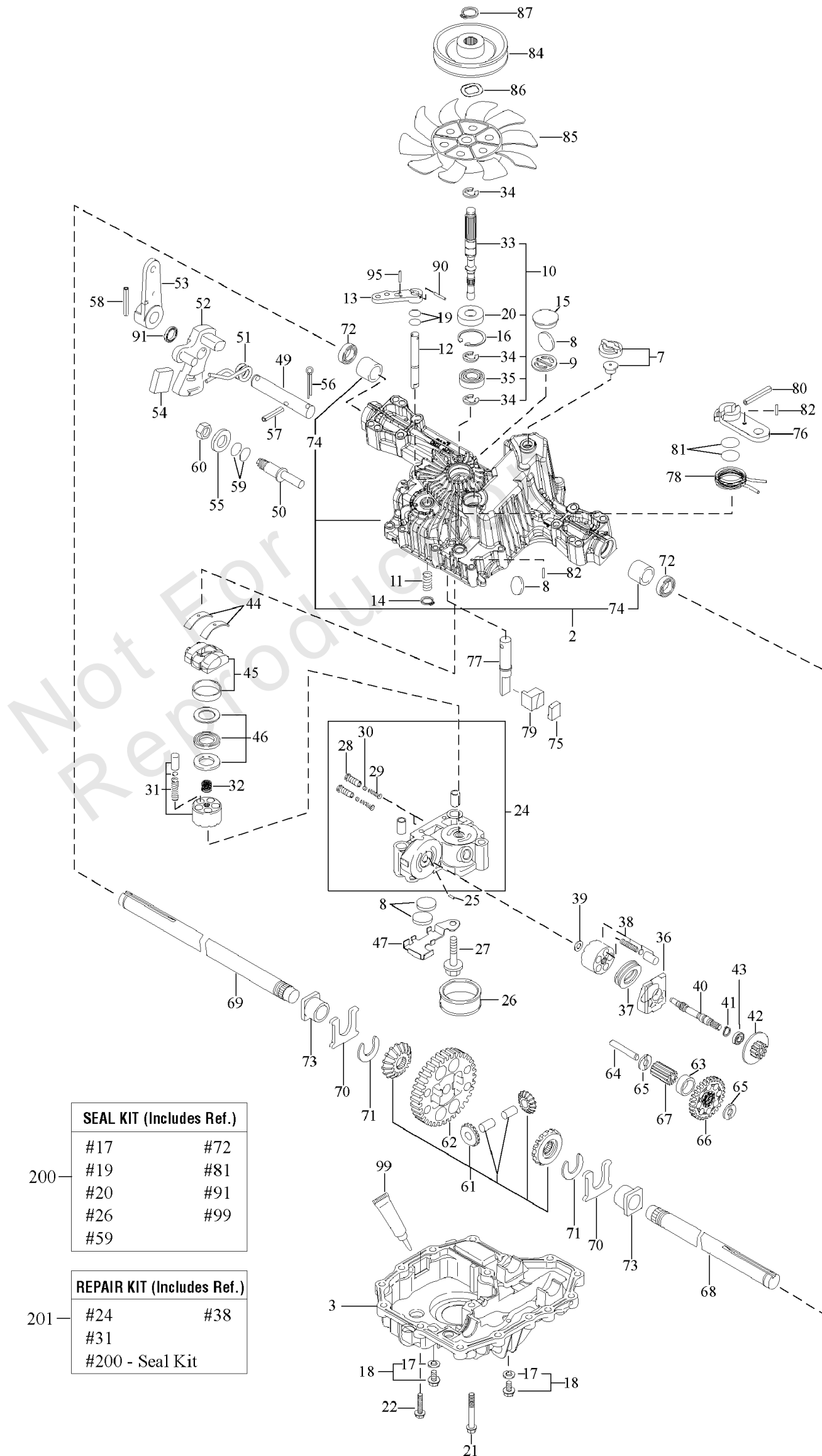

SEAL KIT (Includes Ref.)	
#17	#72
#19	#81
#20	#91
#26	#99
#59	

REPAIR KIT (Includes Ref.)	
#24	#38
#31	
#200 - Seal Kit	

Transmission SERVICE PARTS - Tuff Torq K46BP

REF NO	PART NO	QTY	DESCRIPTION
57	1724296		SPRING PIN 6 * 36
58	1718100		ROLL PIN 6 * 40
60	1708692		NUT 12
61	-----		*KIT, Differential Gear
62	-----		*FINAL GEAR (54T)
63	-----		*FINAL PINION COLLAR
64	-----		*REDUCTION SHAFT
65	1724948		WASHER, 12 * 32 * 3.2
66	-----		*REDUCTION GEAR (37T)
67	-----		*FINAL PINION GEAR (10T)
68	1724303		AXLE SHAFT, Left
69	1724304		AXLE SHAFT, Right
70	-----		*THRUST WASHER
71	1718113		RING 17
72	1718111		SEAL 19 * 32 * 8
73	1718110		BUSHING, 19 * 25
74	-----		*BUSHING, 19.05
75	1724305		BRAKE SHOE
76	1724306		BRAKE LEVER
77	-----		*BRAKE SHAFT
78	-----		*BRAKE RETURN SPRING
79	1724309		BRAKE ACTUATOR
80	1724310		SPRING PIN 5 * 32
82	1724311		SPRING PIN 4 * 16
84	1732918		PULLEY D
85	1724314		FAN, White
86	1724315		WASHER, Wave
87	1724316		SNAP RING
90	-----		*SPRING PIN 3.0A * 20
95	-----		*SPRING PIN 3.0A * 16
99	-----		*SEALANT
200	1727541		K46 & T40 SEAL KIT (ALL MODELS)
201	-----		*REPAIR KIT K46

Footnotes:

*Note: See your local authorized dealership for Tuff Torq parts and warranty or contact Tuff Torq at www.tufftorqservices.com (U.S. 1-866-572-3441; Int'l 01-423-585-1977)

Wheels & Tires Group

Note: Unless noted otherwise, use the standard torque specifications

Mfg. No: 2691023-00

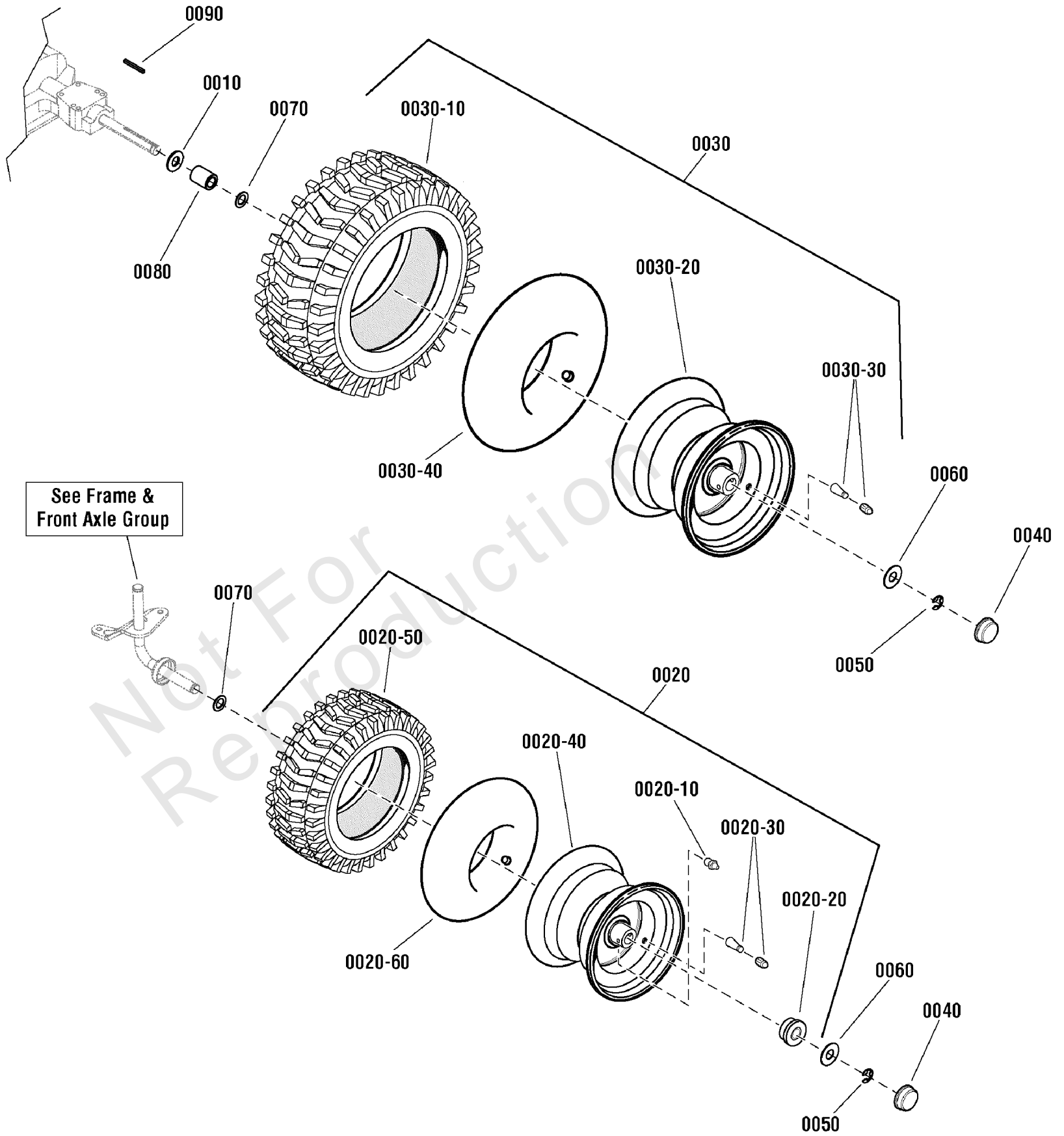

Wheels & Tires Group

REF NO	PART NO	QTY	DESCRIPTION
0010	2860202SM	2	WASHER, 3/4 x 1-5/8 OD x 1/8 Thick
0020	1729708SM	2	WHEEL & TIRE ASSEMBLY, Front 15" X 6.00-6 K358 Tread
0020-10	2812808SM	1	FITTING, Lube, .250-28 Taper Thread
0020-20	1752171YP	2	BUSHING, Flanged, 3/4" ID x 1.380" OD, Front Wheels (2Per Wheel)
0020-30	2172353SM	1	VALVE STEM & CAP, Air .453 Dia 0.88 Long
0020-40	-----	1	WHEEL & BUSHINGS ASSEMBLY, Front
0020-50	1731951SM	1	TIRE, 15 X 6.00 - 6 Turf Rider, Kenda
0020-60	1664090SM	2	TUBE, Tire, 4.10/3.50-6
0030	7101569YP	2	WHEEL & TIRE ASSEMBLY, 22 X 9.5-12 -(52" Models Only)
0030	7101563YP	2	WHEEL & TIRE ASSEMBLY, 20 x 10.0-8 -(42", 46" & 48" Models)
0030	7101560YP	2	WHEEL & TIRE ASSEMBLY, 20 x 8.0-8 -(42" Models Only)
0030-10	7101568YP	2	TIRE, 22 x 9.50-12, 2 Ply K358 -(52" Models Only)
0030-10	7101562YP	2	TIRE, 20 x 10-8, 2 Ply K358 -(42", 46" & 48" Models)
0030-10	7101559YP	2	TIRE, Turf 20 X 8.00 - 8 K358 2Ply Tubeless -(42" Models Only)
0030-20	-----	2	RIM -(All Models)
0030-30	2172353SM	2	VALVE STEM & CAP, Air .453 Dia 0.88 Long -(All Models)
0030-40	2173477SM	2	TUBE, Tire, 20 X 8.00 -10 -(52" Models Only)
0030-40	2164247SM	2	TUBE, Tire, 16 X 6.50 - 8 -(42" & 46" Models Only)
0040	094618MA	4	HUB CAP
0050	0011X3MA	4	E-RING, .750 ID, .050 Thk
0060	17X195MA	4	WASHER, .765 ID, 1.8 OD, .0598 Thk, Flat ZP
0070	17X160MA	4	WASHER, .76 X 1.25 X 16 GA, Flat
0080	1730181SM	2	SPACER, 0.77 ID x 1-1/4 OD x 1.65 LG PM, Black
0090	021553MA	2	KEY, Square, 3/16 x 3/16 x 2

Footnotes:

Note* Not a serviceable part, service wheel complete

Hardware Identification & Torque Specifications

Torque Specification Chart								
FOR STANDARD METRIC MACHINE HARDWARE (Tolerance ± 20%)								
Property Class	5.6		8.8		10.9		12.9	
	Class 5.6		Class 8.8		Class 10.9		Class 12.9	
Size Of Hardware	in/lbs	Nm.	in/lbs	Nm.	in/lbs	Nm.	in/lbs	Nm.
	ft/lbs		ft/lbs		ft/lbs		ft/lbs	
M3	5.88	.56	13.44	1.28	19.2	1.80	22.92	2.15
M4	13.44	1.28	30.72	2.90	43.44	4.10	52.56	4.95
M5	26.4	2.50	60.96	5.75	5.97	8.10	7.15	9.7
M6	44.64	4.3	7.3	9.9	10.3	14	12.1	16.5
M7	5.2	7.1	12.1	16.5	16.9	23	19.9	27
M8	7.7	10.5	17.7	24	25	34	29	40
M10	15	21	35	48	50	67	59	81
M12	26	36	61	83	86.2	117	103	140
M14	42	58	101	132	136	185	162	220
M16	64	88	147	200	210	285	250	340
M18	89	121	202	275	287	390	346	470
M20	126	171	290	390	405	550	486	660
M22	169	230	390	530	559	745	656	890
M24	217	295	497	375	708	960	840	1140
M27	320	435	733	995	1032	1400	1239	1680
M30	435	590	995	1350	1401	1900	1681	2280
M33	590	800	1349	1830	1902	2580	2278	3090
M36	759	1030	1740	2360	2441	3310	2935	3980
M39	988	1340	2249	3050	3163	4290	3798	5150

Torque Specification Chart						
FOR STANDARD MACHINE HARDWARE (Tolerance ± 20%)						
Hardware Grade	No Marks		SAE Grade 5		SAE Grade 8	
	SAE Grade 2		SAE Grade 5		SAE Grade 8	
Size Of Hardware	in/lbs	Nm.	in/lbs	Nm.	in/lbs	Nm.
	ft/lbs		ft/lbs		ft/lbs	
8-32	19	2.1	30	3.4	41	4.6
8-36	20	2.3	31	3.5	43	4.9
10-24	27	3.1	43	4.9	60	6.8
10-32	31	3.5	49	5.5	68	7.7
1/4-20	66	7.6	8	10.9	12	16.3
1/4-28	76	8.6	10	13.6	14	19.0
5/16-18	11	15.0	17	23.1	25	34.0
5/16-24	12	16.3	19	25.8	29	34.0
3/8-16	20	27.2	30	40.8	45	61.2
3/8-24	23	31.3	35	47.6	50	68.0
7/16-14	30	40.8	50	68.0	70	95.2
7/16-20	35	47.6	55	74.8	80	108.8
1/2-13	50	68.0	75	102.0	110	149.6
1/2-20	55	74.8	90	122.4	120	163.2
9/16-12	65	88.4	110	149.6	150	204.0
9/16-18	75	102.0	120	163.2	170	231.2
5/8-11	90	122.4	150	204.0	220	299.2
5/8-18	100	136	180	244.8	240	326.4
3/4-10	160	217.6	260	353.6	386	525.0
3/4-16	180	244.8	300	408.0	420	571.2
7/8-9	140	190.4	400	544.0	600	816.0
7/8-14	155	210.8	440	598.4	660	897.6
1-8	220	299.2	580	788.8	900	1,244.0
1-12	240	326.4	640	870.4	1,000	1,360.0

The guides and ruler furnished below are designed to help you select the appropriate hardware.



Nut, M8

Thread Diameter (mm)

Inside Diameter (in) Threads per inch

Nut, 1/2-16

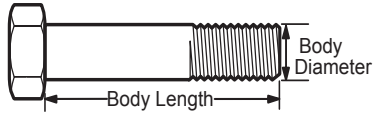

Screw, M8- 1.25 x 25

Thread Diameter (mm) Distance between threads (mm) Body Length (mm)

Body Diameter Threads per inch Body Length (in)

Screw, 1/2- 16 x 2



Standard Hardware Sizing

When a washer or nut is identified as 1/2" (M8), this is the *Nominal size*, meaning the *inside diameter* is 1/2 inch (8mm metric thread diameter); if a second number is present it represents the *threads per inch* (distance between threads).

When bolt or capscrew is identified as 1/2 - 16 x 2" (M8 - 1.25 x 50), this means the *Nominal size*, or body diameter is 1/2 inch (8mm metric thread diameter), the second number, 16, represents the *threads per inch*, (*distance between threads*). The final number is the body length of the bolt or screw, 2 inches (50mm).

NOTES

- These torque values are to be used for all hardware excluding: locknuts, self-tapping screws, thread forming screws, sheet metal screws and socket head setscrews.
- Recommended seating torque values for locknuts:
 - for prevailing torque locknuts - use 65% of grade 5 torques.
 - for flange whizlock nuts and screws - use 135% of grade 5 torques.
- Unless otherwise noted on assembly drawings, all torque values must meet this specification.

Common Hardware Types

Hex Head Capscrew



Washer



Carriage Bolt



Hex Nut

Wrench & Fastener Size Guide

1/4" Bolt or Nut Wrench—7/16"	5/16" Bolt or Nut Wrench—1/2"	3/8" Bolt or Nut Wrench—9/16"	7/16" Bolt or Nut Wrench (Bolt)—5/8" Wrench (Nut)—11/16"	1/2" Bolt or Nut Wrench—3/4"
M6 Bolt or Nut Wrench—10mm	M8 Bolt or Nut Wrench—13mm	M10 Bolt or Nut Wrench—17mm	M12 Bolt or Nut Wrench—19mm	M14 Bolt or Nut Wrench—22mm

