



Parts Manual

Mfg. No: 2690441
LT2042, 42" 20 HP Hydro Drive Tractor
RMO LT200 Series

Model Components	Page
38" & 42" Mower Deck - Belt, Idler Arm & Hitch Group.....	4
38" & 42" Mower Deck - Height Adjustment & Roller Bar Group.....	6
38" & 42" Mower Deck - Housing, Arbors & Blades Group.....	8
Controls Group.....	10
Decals Group.....	12
Electrical Group.....	16
Engine & Electric Clutch Group, 38" & 42".....	20
Frame & Front Axle Group.....	22
Hood, Grille & Dash Group.....	26
Lift Group - Manual.....	28
Seat Deck & Fuel Tank Group.....	30
Steering Group.....	32
Transmission Group - Tuff Torq K46BP.....	34
Wheels & Tires Group.....	36
Wiring Schematic (1728097).....	38
Torque Specification Chart.....	40

Not For
In Reproduction

38" & 42" Mower Deck - Belt, Idler Arm & Hitch Group

REF NO	PART NO	QTY	DESCRIPTION
1	1677135A	1	GUARD, Spring -(Used on Kevlar Belts)
1	1732884A	1	GUARD, Spring -(Used on A-Wedge Aramid Belts)
2	2860361	1	CAPSCREW, Hex Washer Head, Taptite, 3/8-16 x 2
3	1924356	1	WASHER, Plain, 13/32 x 1-1/2 x 1/8
4	1731944A	1	ARM
5	1729007	1	SPACER, 0.387 ID x 1-1/2 OD x 1.04 LG Powdered Metal
6	1922130	1	CAPSCREW, Hex Head, 3/8-16 x 2-1/4
7	1922755	4	WASHER, 3/8
8	7018574	2	IDLER, Flat
9	1931277	2	NUT, Hex, Flange Whizlock, 5/16-18
10	1921971	1	CAPSCREW, Hex Head, 3/8-16 X 1-3/4
11	1731911A	1	SUPPORT, Idler
12	1931211	2	NUT, Whizlock, 3/8-16
13	1731311	1	SPRING, Extension 07.75 LG Black
14	1930645	1	NUT, 3/8-16, Hex Flange MAC Locking Large, Black
15	1931333	2	BOLT, Carriage, 5/16-18 x 3/4
16	1732204	1	V-BELT, 91.10 LG Kevlar -(Used on 38" Domestic Models)
16	1732205	1	V-BELT, HA Shallow-Groove, .34" -(Used on 42" Domestic Models)
16	1733217	1	V-BELT, 91.10 LG A-Wedge Aramid -(Used on 38" CE/Export Models)
16	1732955	1	V-BELT, A Wedge Deep-Groove, .44" -(Used on 42" CE/Export Models)

38" & 42" Mower Deck - Height Adjustment & Roller Bar Group

Note: Unless noted otherwise, use the standard torque specifications

Mfg. No: 2690441

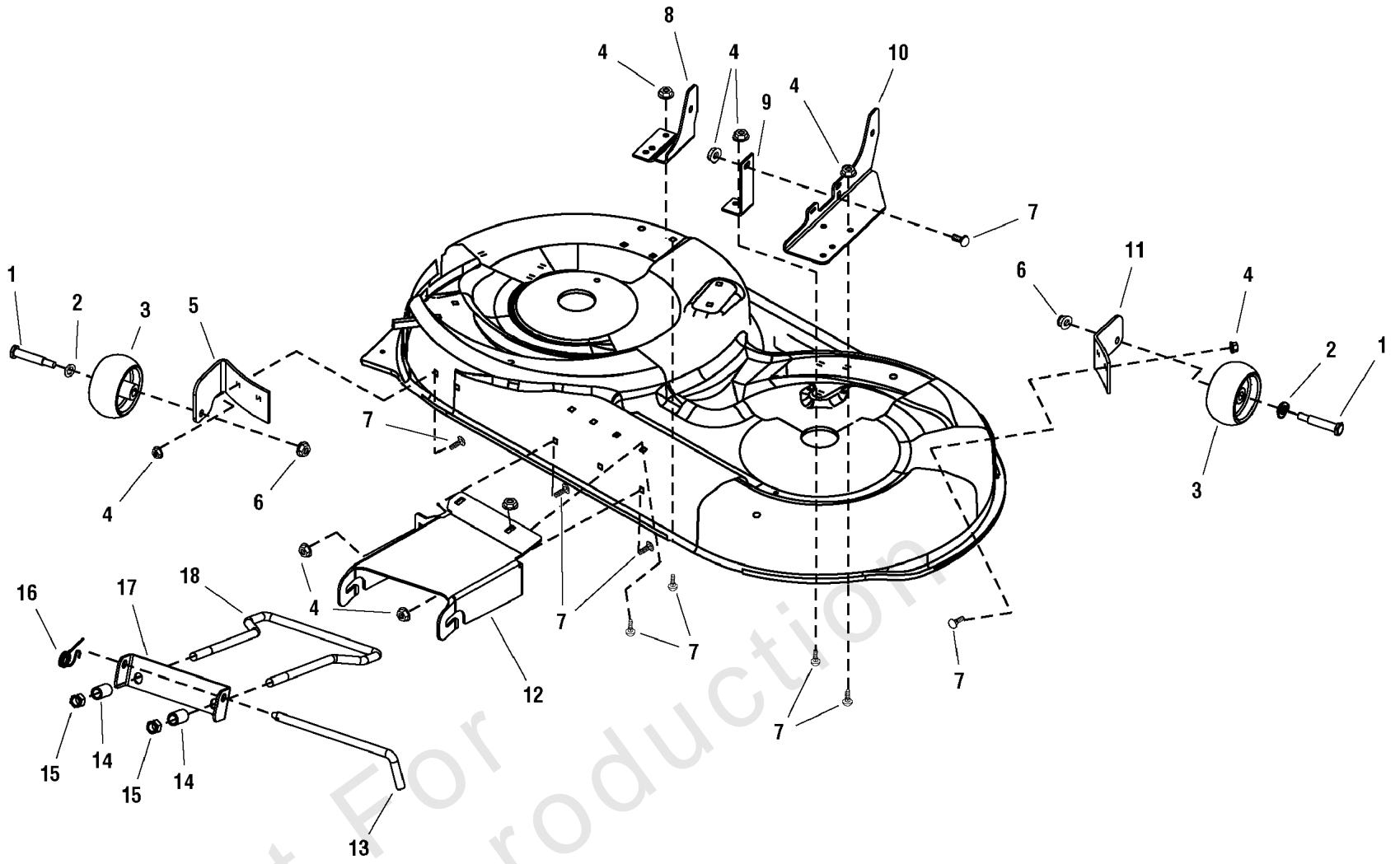

38" & 42" Mower Deck - Height Adjustment & Roller Bar Group

REF NO	PART NO	QTY	DESCRIPTION
1	2108765	2	BOLT, Rear Wheel -(42" Only)
2	1960170	2	WASHER, 1/2 -(42" Only)
3	1714760	2	WHEEL, Gauge -(42" Only)
4	1931277	11	NUT, Hex, Flange Whizlock, 5/16-18 -(38" Only)
4	1931277	13	NUT, Hex, Flange Whizlock, 5/16-18 -(42" Only)
5	1731402A	1	SUPPORT, Gauge Wheel RH 7 GA -(42" Only)
6	1960687	2	NUT, Hex Flange, 3/8-16 ESNA -(42" Only)
7	1931333	11	BOLT, Carriage, 5/16-18 x 3/4 -(38" Only)
7	1931333	13	BOLT, Carriage, 5/16-18 x 3/4 -(42" Only)
8	1730072D	1	SUPPORT, Mower RH
9	1730201D	1	BRACE, Mower Support -(38" Only)
10	1730071D	1	SUPPORT, Mower LH
11	1731403A	1	SUPPORT, Gauge Wheel LH 7 GA -(42" Only)
12	1731967D	1	HITCH, Front 38" Mower
12	1731966D	1	HITCH, Front 42" Mower
13	1731414	1	PIN, Hitch
14	1679166	2	SPACER, .532 ID x 3/4 OD x 1-1/4 LG Yellow
15	1960379	2	NUT, ESNA, Lock, 1/2-13 (Thin)
16	2176012	1	CLIP, Pin, Safety
17	1730221A	1	HANGER, Front Mower
18	1730097	1	ROD, Bail Mowers Yellow

38" & 42" Mower Deck - Housing, Arbors & Blades Group

Note: Unless noted otherwise, use the standard torque specifications

Mfg. No: 2690441

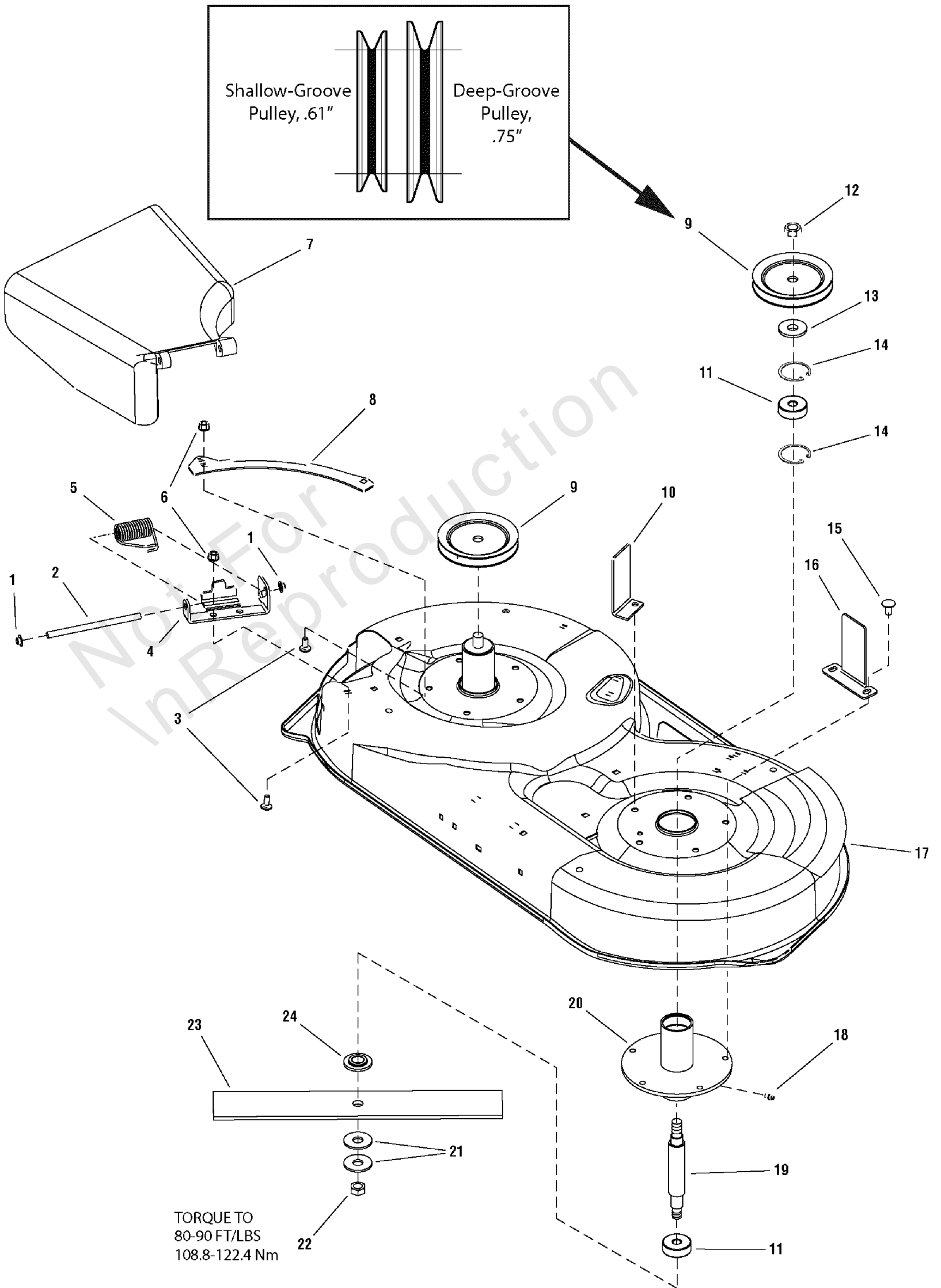

38" & 42" Mower Deck - Housing, Arbors & Blades Group

REF NO	PART NO	QTY	DESCRIPTION
1	1960093SM	2	NUT, Push, 3/8
2	094957ZMA	1	ROD, Deflector
3	1931333SM	6	BOLT, Carriage, 5/16-18 x 3/4
4	721369A	1	BRACKET, Hinge 9GA
5	0166X4MA	1	SPRING, Torsion
6	1931277SM	6	NUT, Hex, Flange Whizlock, 5/16-18
7	094707MA	1	DEFLECTOR & SUPPORT ASSEMBLY, Chute Riveted
8	720911A	2	PLATE, Rear -(38" Only)
8	721083A	2	PLATE, Rear -(42" Only)
9	1732354SM	2	PULLEY, .68" Deep-Groove -(42" Only, must be used with deep-groove belt)
9	1731378SM	2	PULLEY, .61" Shallow-Groove -(38" Only, must be used with shallow-groove belt)
-	1732952SM	2	PULLEY, .75" Deep-Groove -(38" Only, must be used with deep-groove belt)
10	1731209ASM	1	UPSTOP, "L" 10GA
11	2108202SM	2	BEARING, Upper
12	1960576SM	2	NUT, Hex Lock, ESNA Light, 5/8-18
13	7072440SM	2	SPACER, Pulley, 38" Deck
14	7012491SM	2	RETAINING RING, Extension, 1-3/4
15	1923683SM	10	SCREW, Hex, Washer Head, Taptite, 3/8-16 x 3/4
16	1732555ASM	1	UPSTOP, "L" 10GA -(38" Only)
17	1687207SM	1	HOUSING, 42" -(42" Only)
17	1687206SM	1	HOUSING, 38" -(38" Only)
18	1704314SM	1	FITTING, Grease
19	7072537SM	1	SHAFT, Spindle, 38" Deck
20	1731372ZSM	1	TUBE & PLATE ASSEMBLY, Spindle
21	7024467SM	4	WASHER, Belleville
22	7091633SM	2	NUT, Hex 9/16-18
23	1731898ASM	2	BLADE, Mower 42" -(42" Only)
23	1731914SM	2	BLADE, Mower 38" -(38" Only)
24	1731917SM	2	WASHER, Spindle Blade Powdered Metal

Controls Group

Note: Unless noted otherwise, use the standard torque specifications

Mfg. No: 2690441

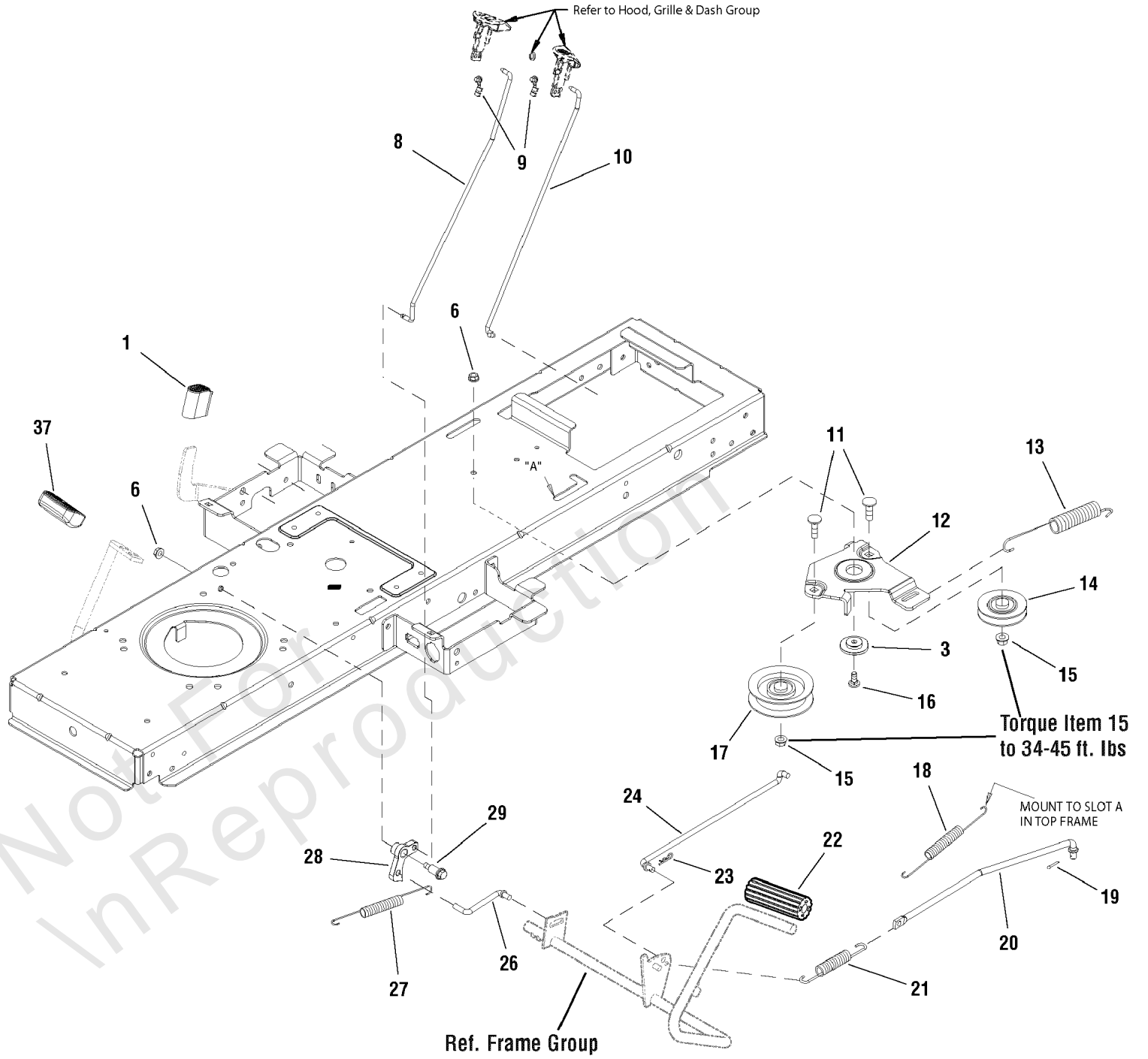

Controls Group

REF NO	PART NO	QTY	DESCRIPTION
1	1727259	1	PAD, Foot Pedal Reverse
3	1727935	2	SPACER, Pivot Powdered Metal
6	1931277	6	NUT, Hex, Flange Whiz Lock, 5/16-18
8	1738760	1	ROD, Cruise Latch, 16.97LG
9	1728111	2	CLIP, Linkage, Black
10	1727267	1	ROD, Parking Brake, 16.38 LG Yellow
11	1960268	2	BOLT, Carriage, 3/8-16 x 1-1/4
12	1727894A	1	BRACKET, Idler 7GA
13	1729620	1	SPRING, Extension 07.52 LG Black
14	1728001	1	PULLEY, 3 OD Plastic
15	1960687	2	NUT, Hex Flange, 3/8-16 ESNA
16	1931335	1	BOLT, Carriage, Short Neck, 5/16-18 x 1
17	1728000	1	PULLEY, Idler
18	1721995	1	SPRING, Extension
19	1918447	1	PIN, Cotter 3/32 x 3/4
20	1727253	1	ROD, Brake, 15.1 LG
21	1731262	1	SPRING, Extension 05.37 LG Black
22	1727261	1	PEDAL, Brake Rubber
23	1722460	1	PIN, Quick
24	1727254	1	ROD, Brake Return, 12.60 LG
26	1727899	1	ROD, Cruise Latch, 2.83 LG
27	2159181	1	SPRING, Tension, Clutch
28	1727897	1	LATCH, Cruise Powdered Metal
29	1728976	1	BOLT, Shoulder 5/16-18 G5
37	1721675	1	PAD, Foot Pedal Forward

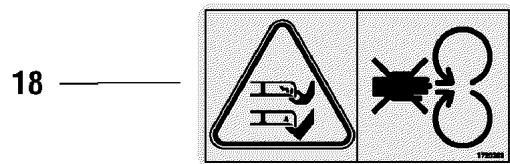
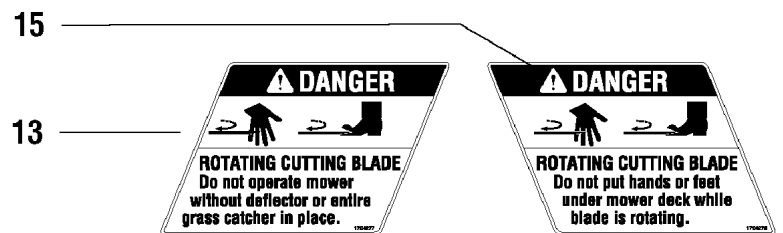
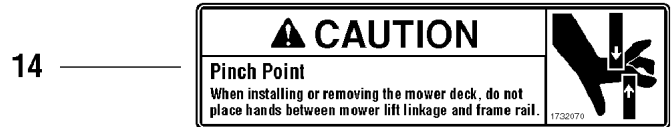
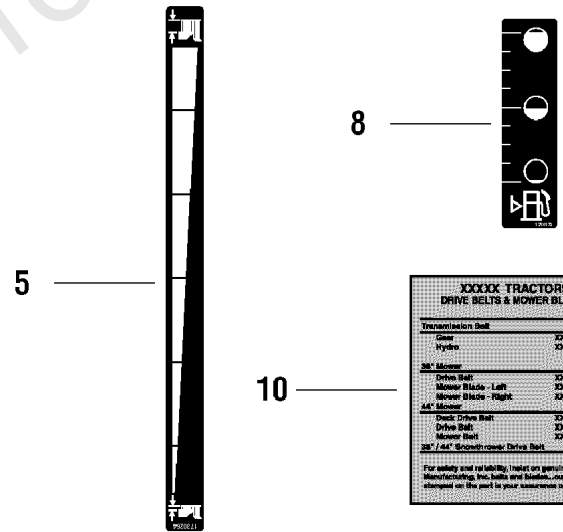
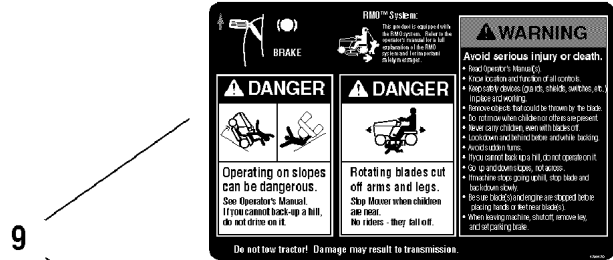
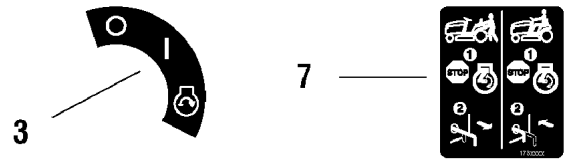
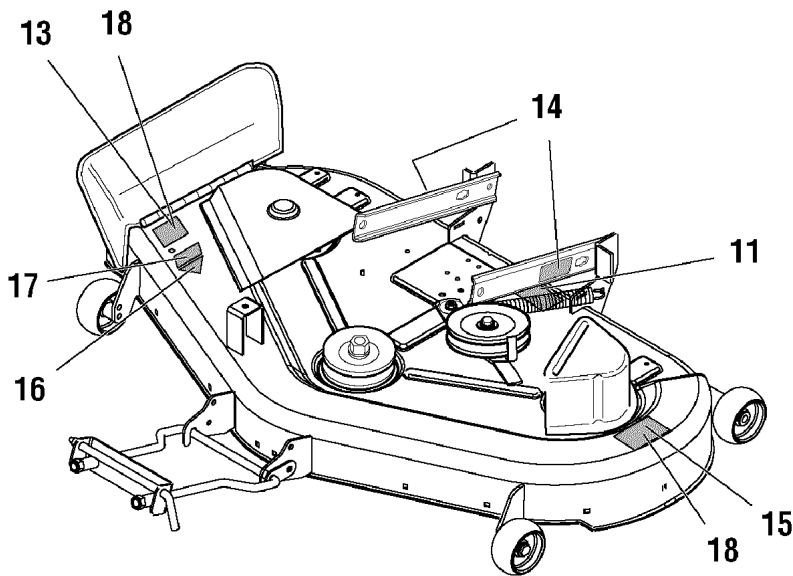
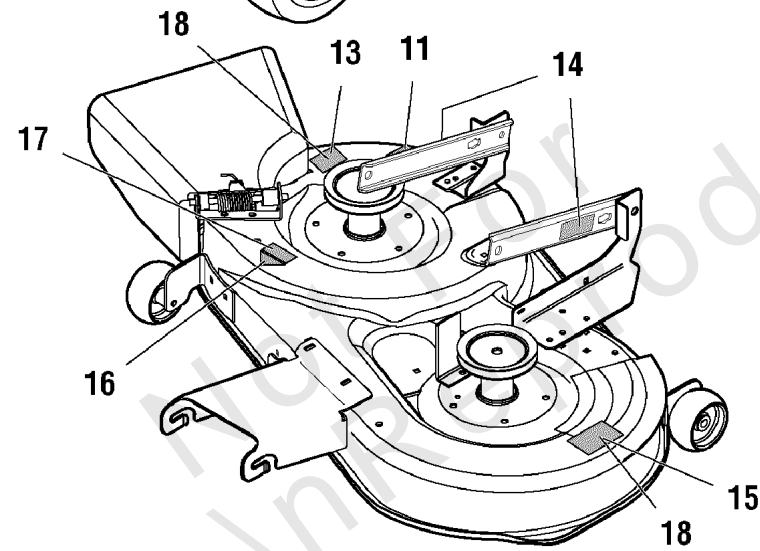
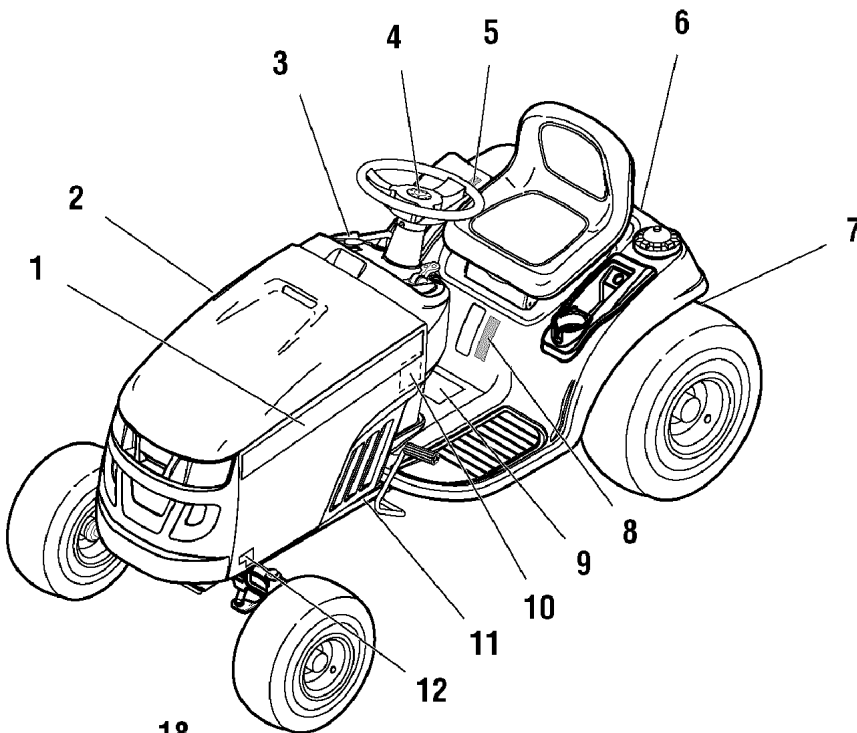

Decals Group

REF NO	PART NO	QTY	DESCRIPTION
1	1731392	1	DECAL, Snapper, LH Hood Stripe
1	7102192	1	DECAL, Snapper, LH Hood Stripe -(Model 2690841 Only)
1	1751632	2	DECAL, Snapper Turtle, Hood -(Model 2691046 Only)
2	1731393	1	DECAL, Snapper, RH Hood Stripe
2	7102191	1	DECAL, Snapper, RH Hood Stripe -(Model 2690841 Only)
3	1722806	1	DECAL, Ignition Switch Symbol, White/Black
4	1731419	1	DECAL, Steering Wheel Icon
4	1736872	1	DECAL, Steering Wheel Icon -(Model 2690841 Only)
4	1739085	1	DECAL, Steering Wheel Icon -(Model 2691046 Only)
5	1730264	1	DECAL, Height of Cut -Not Used on 40" Mower
6	1731955	1	DECAL, Snapper Rear Stripe, Silver/ 8.5LG
6	7102196	1	DECAL, Snapper Rear -(Model 2690841 Only)
6	7104148	1	DECAL, Logo, 7.88" -(Model 2691046 Only)
7	1730202	1	DECAL, Transmission Tow/ Release Lever
8	1730172	1	DECAL, Fuel Level
9	1730170	1	DECAL, Tunnel
9	1723175	1	DECAL, Safety Instructions -(CE/Export)
9	1734027	1	DECAL, Tunnel -(France Models Only)
9	1734027	1	DECAL, Safety Instructions -(Used only on ACS models)(CE/Export)
9	1750191	1	DECAL, Tunnel -(Model 2691046 Only)
10	1733250	1	DECAL, Belts,Blades -(France Models Only)
10	1733251	1	DECAL, Belts, Blades
11	-----	1	* DECAL, ID Plate
12	1731927	1	DECAL, LT200 18.5HP
12	1731928	1	DECAL, LT200 20HP
12	1731929	1	DECAL, LT200 22HP
12	1753432YP	2	DECAL, Model, ELT19546
13	1704277	1	DECAL, Danger, Chute in Place -Not Used on 40" Mower
13	5102457	1	DECAL, Danger, Discharge
14	1732070	1	DECAL, Pinch Point -Not Used on 40" Mower
15	1704276	1	DECAL, Danger, Hand Under Deck -Not Used on 40" Mower
16	-----	1	* DECAL, OPEI
17	1722787	1	DECAL, 38"
17	1731924	1	DECAL, 42"
17	1722789	1	DECAL, 44"
17	1751641	1	DECAL, 46"
17	1722790	1	DECAL, 50"

Footnotes:

Note* Not a serviceable part.

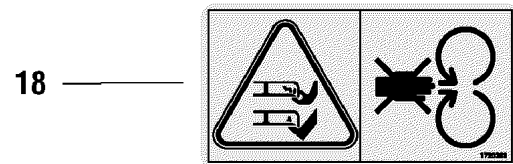
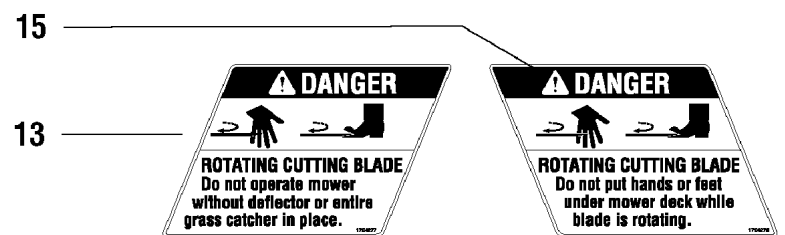
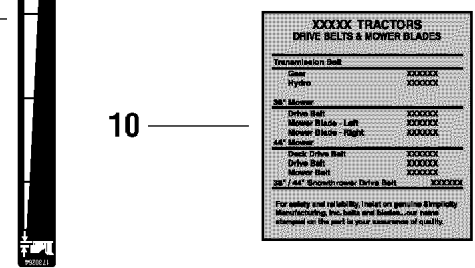
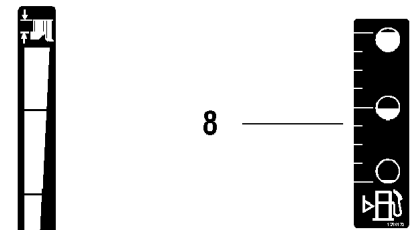
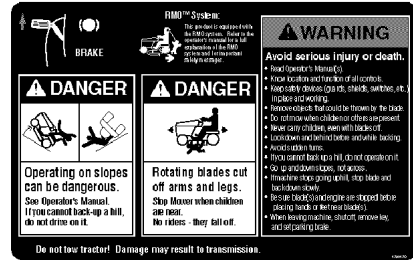
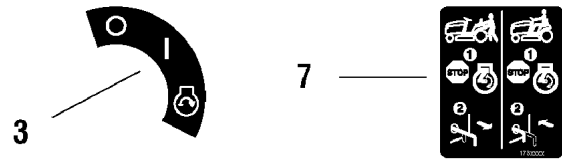
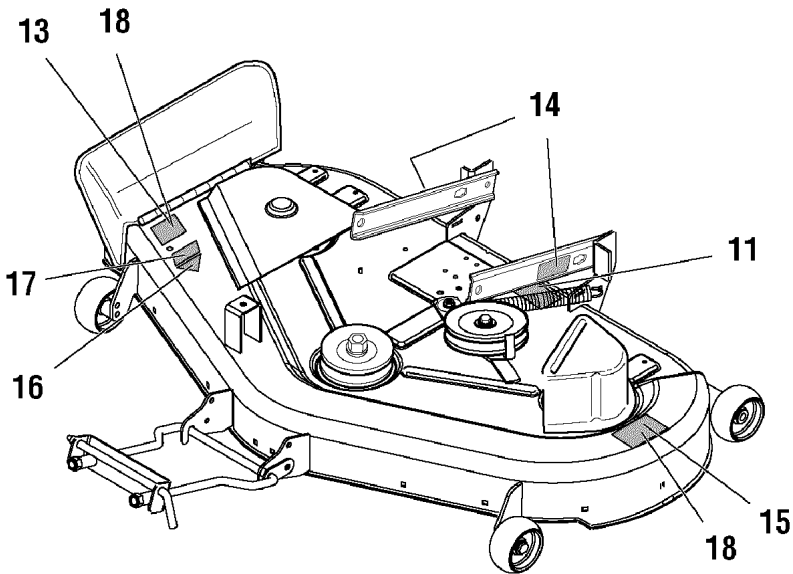
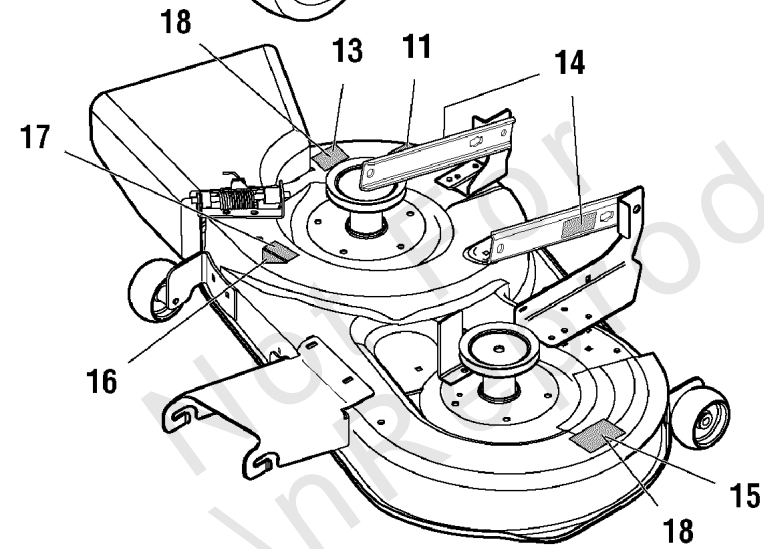
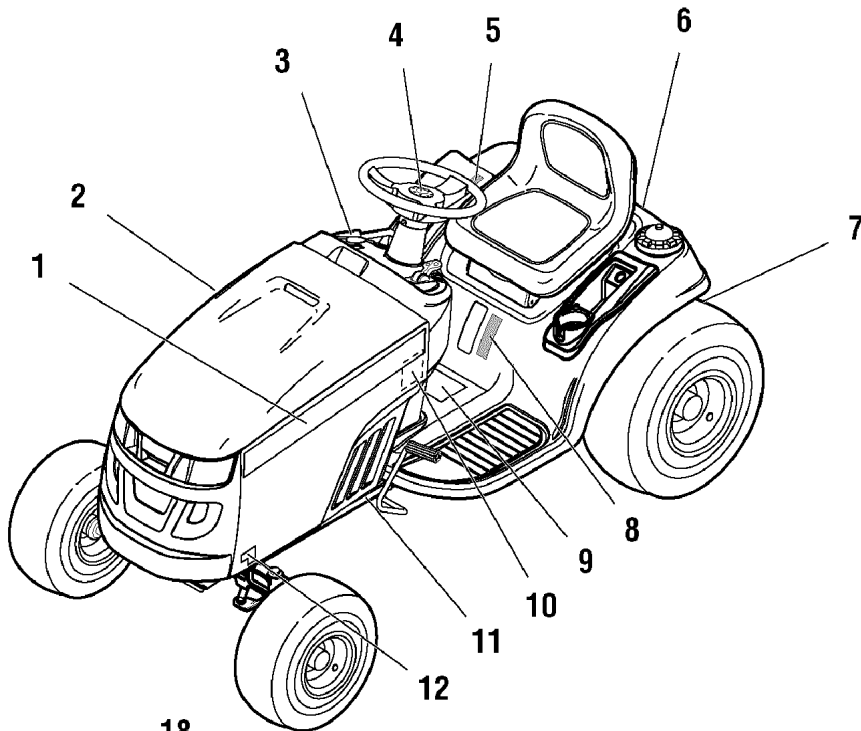

Decals Group

REF NO	PART NO	QTY	DESCRIPTION
18	1720389	1	DECAL, Hand Under Deck -(CE/Export)
18	5102420	2	DECAL, Danger, Mower Deck

Not For
In Reproduction

Footnotes:

Note* Not a serviceable part.

Electrical Group

Note: Unless noted otherwise, use the standard torque specifications

Mfg. No: 2690441

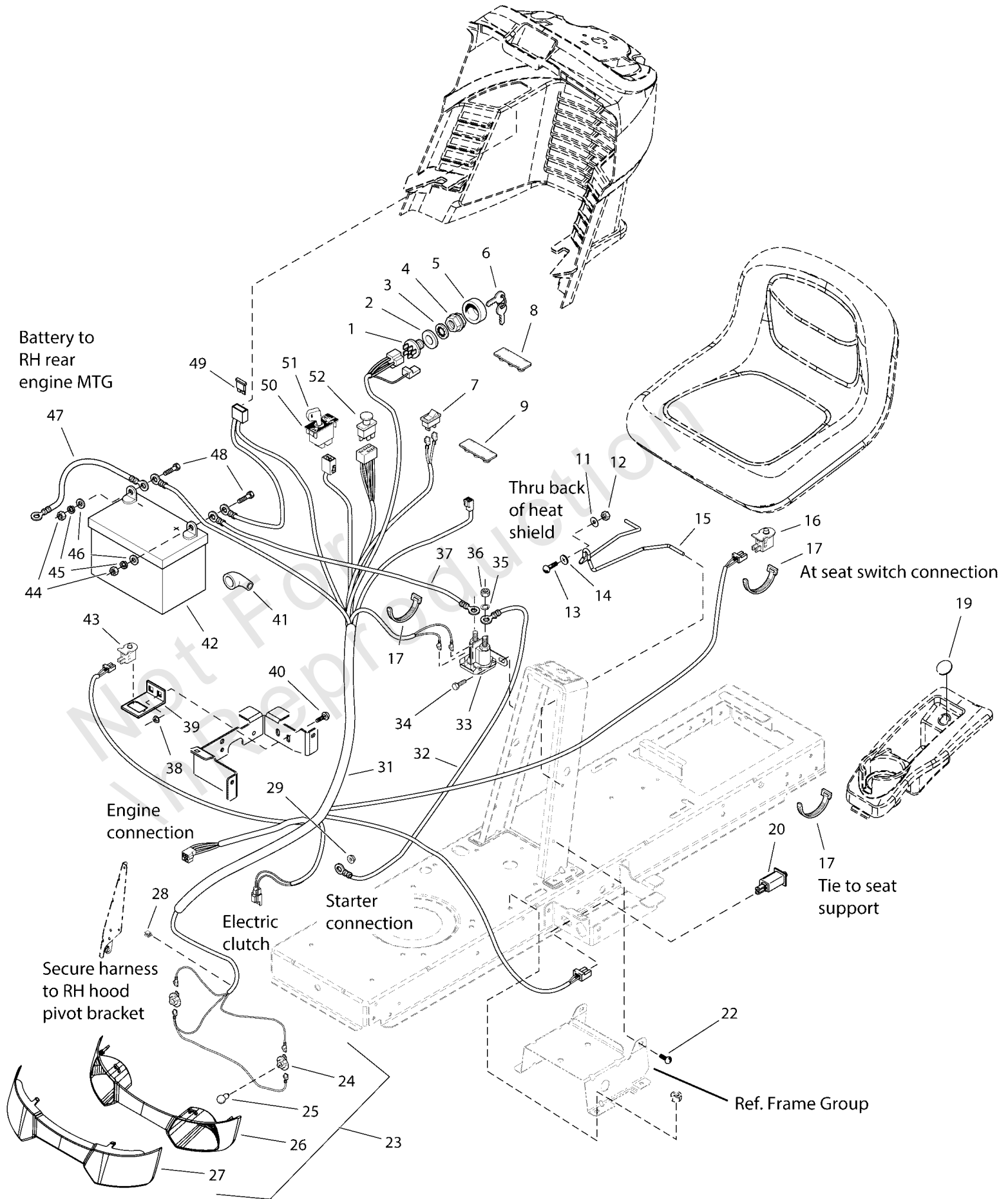

Electrical Group

REF NO	PART NO	QTY	DESCRIPTION
1	1716061	1	SWITCH, Ignition, 6-Pole (Hdwe. Not Included) -(Includes Ref. 2, 3, 4 & 5)
2	2101025	1	WASHER, 5/8
3	1960547	1	LOCKWASHER, Internal Tooth, 5/8
4	1717549	1	NUT, Hex, Flange, 5/8-32
5	1717550	1	COVER, Ignition
6	1717163	1	IGNITION KEY (Set of 2)
7	1716951	1	SWITCH, Headlights, 2 Terminal
8	1722611	1	PLUG, Hole, Square
9	1729993	1	PLUG, Hour Meter -(Kohler and B&S Single)
10	1728068	1	METER, Hour, LCD -(B&S V-Twin Only)
11	1960353	1	WASHER, Plain, 1/4 (6 Total for Export)
12	2860293	1	NUT, Wing, 1/4-20
13	1931318	1	BOLT, Carriage, 1/4-20 x 7/8
14	1960518	1	NUT, Push On
15	1730007	1	HOLD DOWN, Battery
16	1732005	1	SWITCH, Push Button (NC)
17	2825094	3	TIE, Self Locking 7-5/16
18	7073090	1	OUTLET, 12 Volt DC Power
19	1732007	1	PLUG, Hole Models W/O 12V Adapter
20	1732006	1	SWITCH, Push Button (NO/NC)
21	1727282A	1	SUPPORT, Battery 12 GA
22	1930601	4	SCREW, Taptite, 5/16-18 x 5/8
23	1727296	1	HEADLIGHT ASSEMBLY -(Includes Ref. Nos. 24, 25, 26 & 27)
24	1723451	2	SOCKET ASSEMBLY
25	1677371	2	BULB, 1141-12V 21CP
26	1728973	1	REFLECTOR, Headlight
27	1728974	1	LENS, Headlight
28	2834683	1	CLIP, Speed Wire
29	1960294	1	NUT, Hex, Flange, 1/4-20
30	1713535	1	COVER, Terminal
31	1728097	1	HARNESS, Wiring -(Use on models with 12 Volt Outlet)
31	1739597	1	HARNESS, Wiring -(Use on models without 12 Volt Outlet)
32	1721830	1	CABLE, Solenoid to Starter
33	1728963	1	SOLENOID
34	1925003	2	SCREW, Taptite, 1/4-20 x 1/2
35	2820426	2	LOCKWASHER, External Tooth, 5/16
36	2820263	2	NUT, Hex, 5/16-24 NF
37	1716549	1	CABLE, #6 x 10 Long, with 2 Ring Terminals, Battery to Solenoid
38	1931277	2	NUT, Hex, Flange Whizlock, 5/16-18
39	1728026A	1	SUPPORT, RMO Switch
40	1931333	2	BOLT, Carriage, 5/16-18 x 3/4
41	1677296	1	BOOT, Insulator
42	-----	1	BATTERY, 12 Volt, 230CCA
42	-----	1	BATTERY, 12 Volt, 230CCA, Deka 8U1L -(CE/Export)
43	1732004	1	SWITCH, Push Button, NO, Black
44	2816622	2	NUT, Hex, Full, 1/4-20

Electrical Group

Note: Unless noted otherwise, use the standard torque specifications

Mfg. No: 2690441

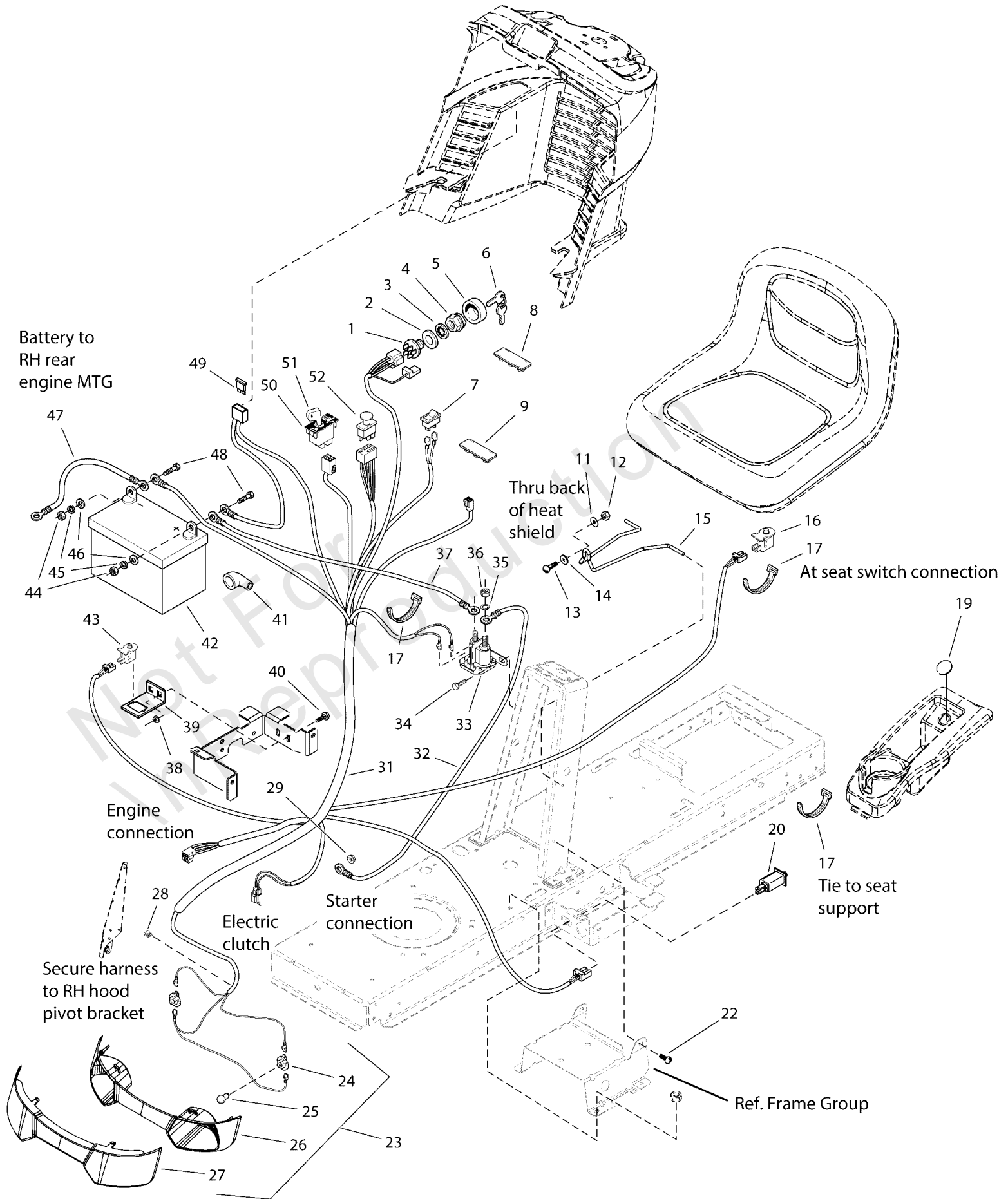

Electrical Group

REF NO	PART NO	QTY	DESCRIPTION
45	2816964	2	LOCKWASHER, 1/4
46	2821319	2	WASHER, 1/4 I.D.
47	1713163	1	CABLE, Battery to Ground
48	2823341	2	CAPSCREW, Hex Head, 1/4-20 x 3/4
49	1731957	1	FUSE, Wiring Harness
50	1726556	1	SWITCH, RMO Module Only
51	1726557SM	1	KEY, w/Hang Tag for RMO Module -(Was 1727185)
52	1722887	1	SWITCH, PTO, Push/Pull Symbols

Not For In Reproduction

Engine & Electric Clutch Group, 38" & 42"

Note: Unless noted otherwise, use the standard torque specifications

Mfg. No: 2690441

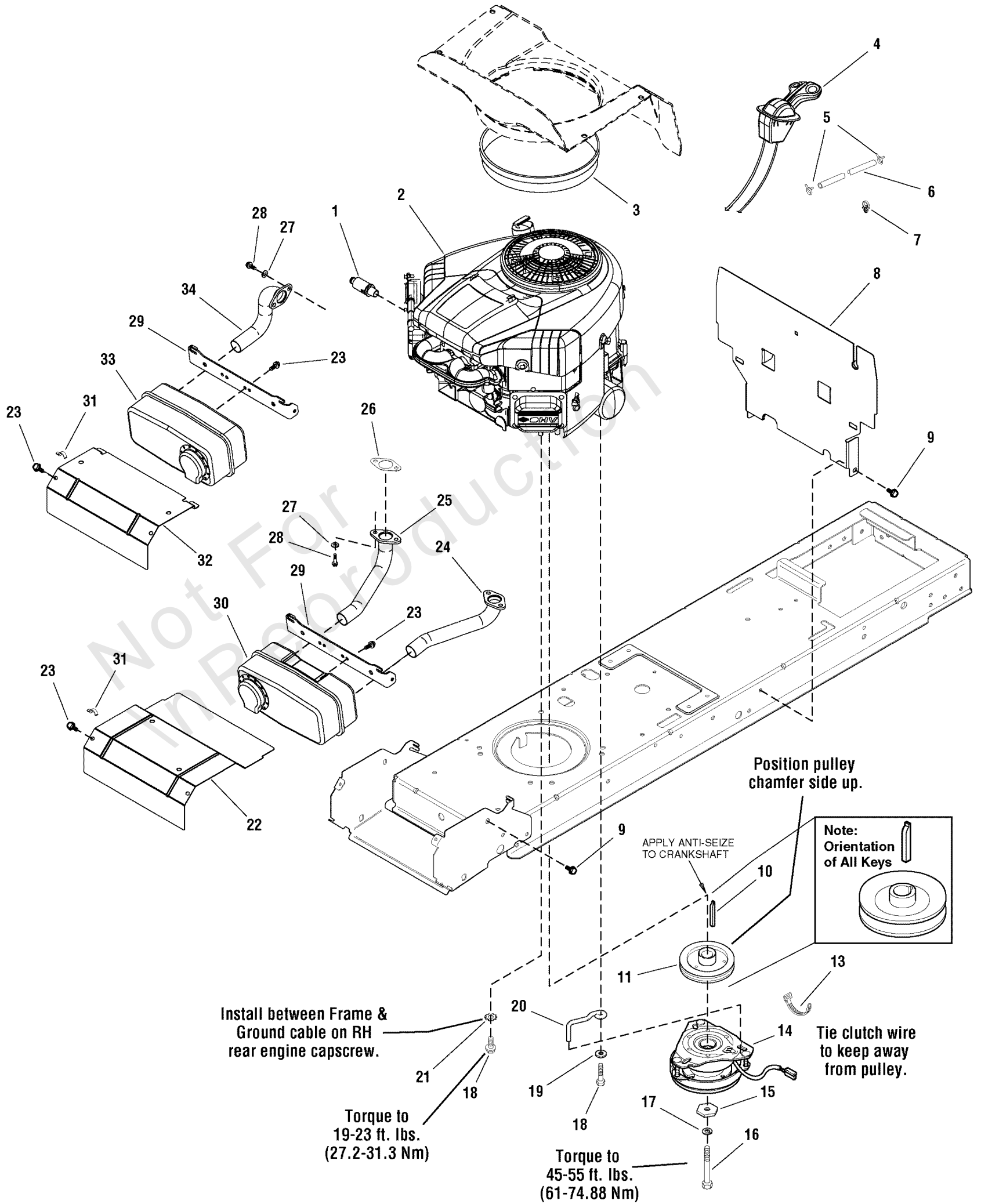

Engine & Electric Clutch Group, 38" & 42"

REF NO	PART NO	QTY	DESCRIPTION
1	1717473	1	VALVE, Oil Drain
2	31P777-0121-B1	1	** ENGINE, 18HP B&S Intek 1 Cylinder, Model 31P777-0121-B1
2	406577-0143-B1	1	** ENGINE, 20HP B&S Intek Twin, Model 406577-0143-B1
3	1731970	1	EDGING, Rubber, Short -(B&S V-Twin)
3	1731971	1	EDGING, Rubber, Long -(B&S Single Only)
4	1731410	1	CONTROL, Throttle Double 20.5, 23.5 B&S Single
4	1731411	1	CONTROL, Throttle Double 34.7, 36 B&S Twin
5	2860112	2	CLAMP, Hose Type E
6	1676861	1	HOSE, Fuel, 45-1/2" Long -(B&S V-Twin)
6	1732001	1	HOSE, Fuel 55" Long -(B&S Single Only)
7	1730268	2	CLIP, Hose, Plastic, Push-In
8	1728058A	1	SHIELD, Heat
9	1930601	4	SCREW, Taptite, 5/16-18 x 5/8
10	1720463	1	KEY, Hi-Pro, 1/4 x 2-1/2
11	1723497	1	PULLEY
13	2825094	1	TIE, Self Locking 7-5/16
14	1718836	1	CLUTCH ASSEMBLY, Long OGURA
15	1708264	1	WASHER
16	1960649	1	CAPSCREW, 7/16-20 x 3-1/2, Hex Head
17	1918199	1	LOCKWASHER, 7/16
18	2828635	4(1)	SCREW, Hex, Washer Head, Taptite, 3/8-16 x 1-1/4
18	2827187	3	CAPSCREW, Hex Head, Taptite, 3/8-16 x 1-1/2 -(B&S Single Only)
19	1924940	1	WASHER, 3/8
20	1732026	1	RETAINER, Clutch, Yellow
21	2820427	1	LOCKWASHER, External Tooth, 3/8
22	1727997A	1	SHIELD, Heat B&S Twin 20GA
23	1925003	4	SCREW, Taptite, 1/4-20 x 1/2
24	1727980	1	PIPE, Exhaust w/Flange LH B&S INT
25	1727979	1	PIPE, Exhaust w/Flange RH B&S INT
26	1731214	2(1)	GASKET, Exhaust B&S
27	1917356	4(2)	LOCKWASHER, 5/16
28	1936228	4(2)	CAPSCREW, Socket Head, 5/16-18 x 3/4
29	1727976A	1	BRACKET, Muffler Mount 12GA
30	1727994	1	MUFFLER, B&S Twin
31	2834683	1	CLIP, Wire
32	1727996A	1	SHIELD, Heat Single Cycle 20GA
33	1727993	1	MUFFLER, B&S Single
34	1728959	1	PIPE, Exhaust w/Flange B&S 1 Cycle

Footnotes:

Note** See your local Briggs & Stratton distributor for parts and service.

Frame & Front Axle Group

Note: Unless noted otherwise, use the standard torque specifications

Mfg. No: 2690441

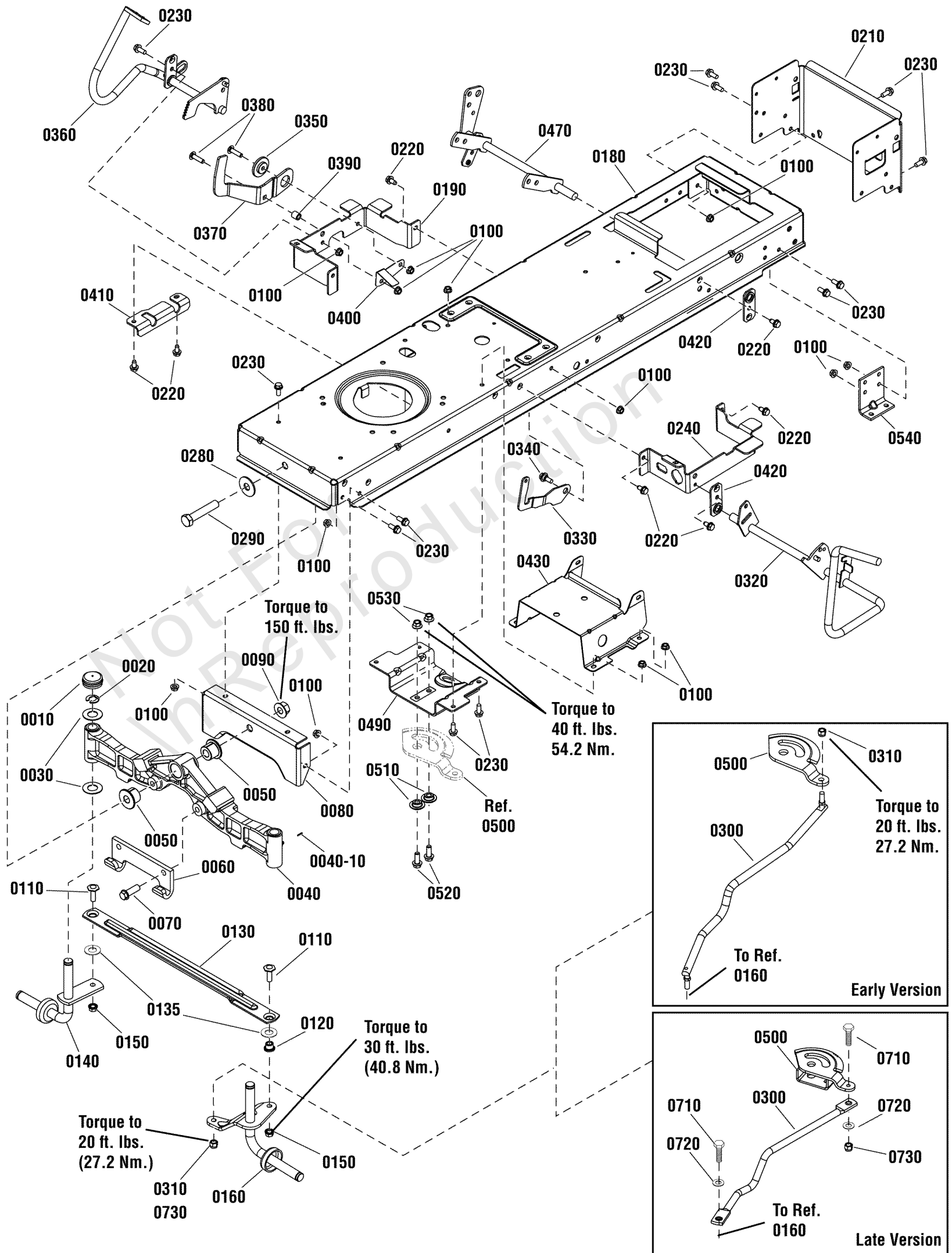

Frame & Front Axle Group

REF NO	PART NO	QTY	DESCRIPTION
0010	1734135	2	CAP, Hub, 1.48 ID x .62 Long
0020	1611710	2	RING, Klipring, 3/4 Dia.
0030	2860183	4	WASHER, 3/4 x 1-5/8 OD x 1/16 Thick
0040	1728018	1	AXLE, Front
0040-10	1704314	3	FITTING, Lube, .250" Drive, .25" Shank Ball Chk Yel
0050	1730186	2	BUSHING, Axle Pivot
0060	1721918	1	HOOK, Mower, Hitch
0070	1960652	2	CAPSCREW, Hex, Whiz Lock, 7/16-14 x 1-1/2
0080	1727902	1	PLATE, Axle Support
0090	2860646	1	NUT, Hex Flange, Two Way, 5/8-11
0100	1931277	24	NUT, Hex Flange, Whiz Lock, 5/16-18
0110	1960032	2	CAPSCREW, Hex Head, 3/8-16 x 1-1/4, G5
0120	1731912	2	BUSHING, 3/8 ID x 5/8 OD x 9/16 Long
0130	1728080A	1	TIE ROD, Flat -(Early Version)
0130	1751964	1	TIE ROD, Flat -(Late Version)
0135	1960703SM	2	WASHER, 5/8 -(Late Version)
0140	1727872A	1	WHEEL SPINDLE ASSEMBLY, R.H.
0150	1930645	2	NUT, Hex Flange, Two Way, Locking, 3/8-16
0160	1727873	1	WHEEL SPINDLE ASSEMBLY, L.H. -(Early Version)
0160	1751922	1	WHEEL SPINDLE ASSEMBLY, L.H. -(Late Version)
0180	1736715A	1	FRAME -(Was 1738937)
0190	1727904	1	SUPPORT, Front Footrest, R.H.
0210	1736746A	1	SUPPORT, Rear Frame
0220	1930601	9	CAPSCREW, Hex Washer Head, Taptite, 5/16-18 x 5/8
0230	1930591	21	CAPSCREW, Hex, Whiz Lock, 5/16-18 x 3/4
0240	885536	1	SUPPORT, Front Footrest, L.H. -(Was 1727905)
0280	1960035	1	WASHER, 5/8 x 1-3/4 OD
0290	2860744	1	CAPSCREW, Hex Head, 5/8-11 x 3-1/4, G5
0300	1727868	1	LINK, Drag (with Ball Joint), 3/8 -(Early Version)
0300	1738051	1	LINK, Drag (with Bearing), 5/16 -(Late Version)
0310	1960747	2	NUT, Hex, Nylock, 3/8-24 -(Early Version)
0320	1736404	1	PEDAL ASSEMBLY, Brake
0330	1735595A	1	LATCH, Brake Lock
0340	1729576	1	BOLT, Shoulder, 5/16-18 x 15/32, G5
0350	1727935	1	SPACER, Pivot, 11/32 ID 1-3/4 OD
0360	1736714	1	PEDAL ASSEMBLY, Forward
0370	1727246A	1	PEDAL, Reverse
0380	1960223	2	BOLT, Carriage, 5/16-18 x 1-1/4, G5
0390	1728024	1	SPACER, Foot Pedal
0400	1728025	1	ACTUATOR, RMO Switch
0410	1727909	1	BRACKET, Pedal Pivot
0420	1727911	2	PLATE, Bearing
0430	1727282	1	SUPPORT, Battery
0470	1737957	1	LIFT SHAFT ASSEMBLY

Frame & Front Axle Group

Note: Unless noted otherwise, use the standard torque specifications

Mfg. No: 2690441

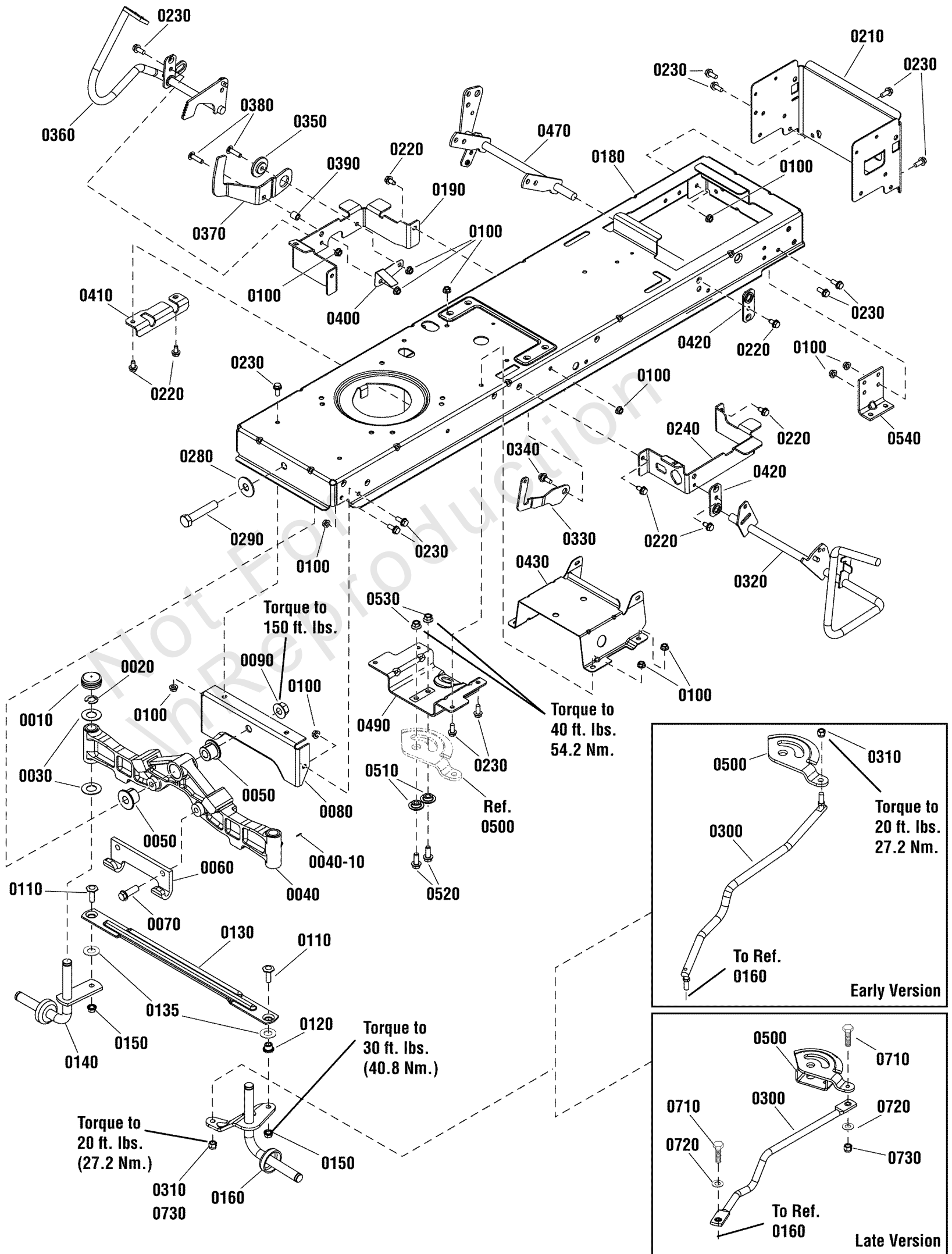

Frame & Front Axle Group

REF NO	PART NO	QTY	DESCRIPTION
0490	1727940	1	BRACKET, Sector Support
0500	1728027	1	GEAR, Steering -(Early Version)
0500	1751110	1	GEAR, Steering, 26 Teeth -(Late Version)
0510	1728122	2	SPACER, Sector Gear, 3/8 ID x 1-1/4 OD
0520	1934654	2	CAPSCREW, Hex, Whiz Lock, 3/8-16 x 1
0530	1930645	2	NUT, Hex Flange, Two-Way Lock, 3/8-16 -(Was 1931211)
0540	1727903	2	SUPPORT, Transmission
0710	1921977	2	CAPSCREW, Hex Head, 5/16-18 x 1-1/4 -(Late Version)
0720	1924874	2	WASHER, 5/16 Flat (.341 I.D. x .87 O.D. X .06 Thick) Black -(Late Version)
0730	1935048	2	NUT, Hex Flange Two-Way Lock, 5/16-18 -(Late Version)

Not For In-Production

Hood, Grille & Dash Group

Note: Unless noted otherwise, use the standard torque specifications

Mfg. No: 2690441

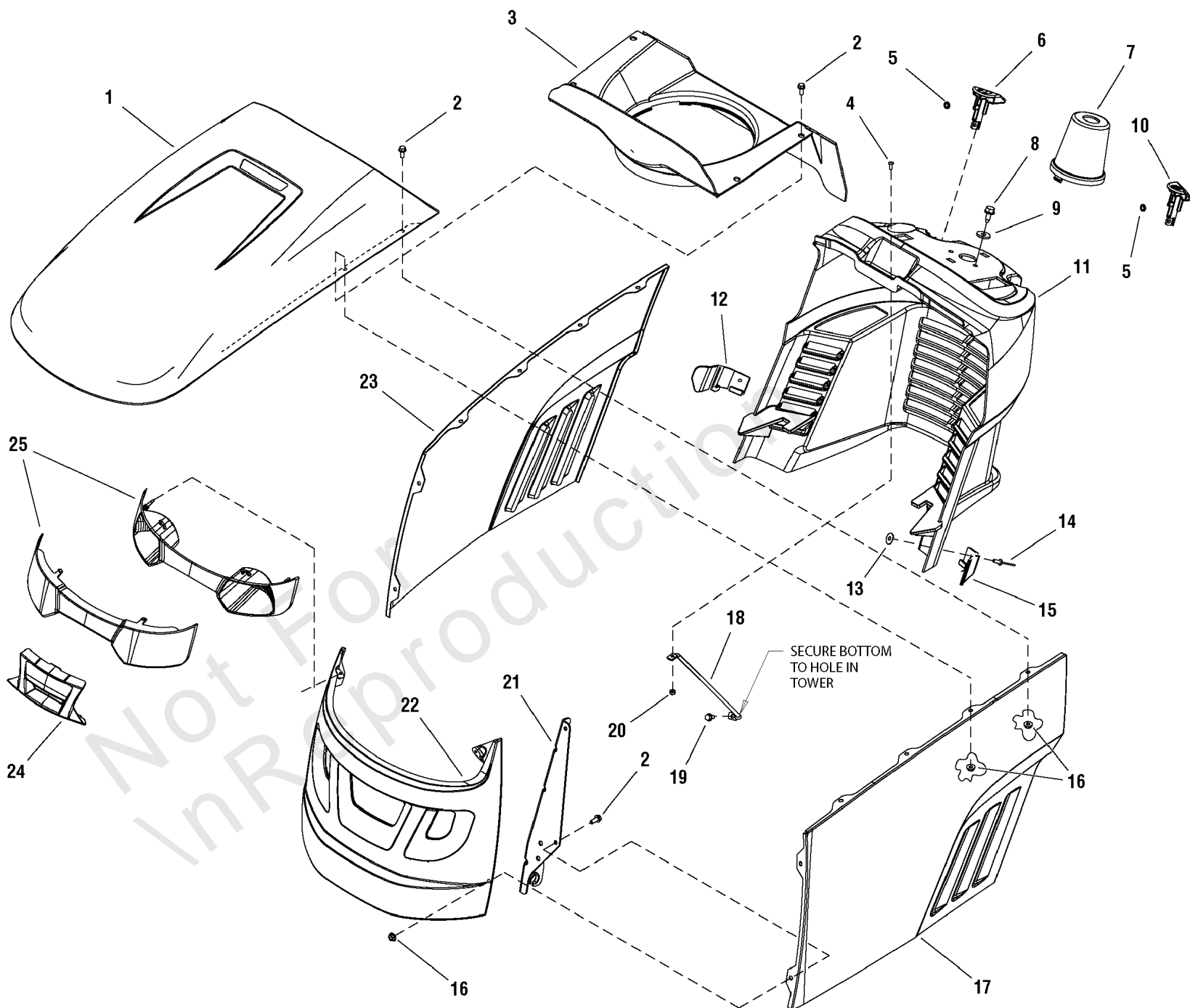

Hood, Grille & Dash Group

REF NO	PART NO	QTY	DESCRIPTION
1	1728031D	1	HOOD, W/Scoop -(Red)
1	1728031BF	1	HOOD, W/Scoop -(White)
2	1960295	12	CAPSCREW, Whizlock, 1/4-20 x 5/8
3	1731891	1	DUCT, Air Inlet Plastic
4	1960392	1	SCREW, Pan Head #10-24 x 1/2
5	1960674	2	PUSH NUT
6	1728090	1	KNOB, Cruise Lock Green Plastic
7	1727999	1	COVER, Steering Shaft Plastic
8	1664847SM	2	CAPSCREW, Hex Head, Taptite, 5/16-18 x 3/4
9	1919381	2	WASHER, Plain, 5/16
10	1728089	1	KNOB, Brake Lock Plastic
11	1727293	1	DASHBOARD
12	1732031	1	GUIDE, Hood RH
13	1960096	2	WASHER
14	1928707	2	RIVET, Pop, Stem Black
15	1732030	1	GUIDE, Hood LH
16	1930641	12	NUT, Hex Flange Whiz, 1/4-20
17	1727295D	1	PANEL, Hood LH Side -(Red)
17	1727295BF	1	PANEL, Hood LH Side -(White)
18	1723123	1	ROD, Dash Support
19	1925003	1	SCREW, Taptite, 1/4-20 x 1/2
20	1933896	1	NUT, Hex, Nylon, Lock, #10-24
21	1727279A	1	HINGE, Hood LH
21	1727280A	1	HINGE, Hood RH
22	1728059D	1	GRILLE -(Red)
22	1728059BF	1	GRILLE -(White)
23	1727294D	1	PANEL, Hood RH Side -(Red)
23	1727294BF	1	PANEL, Hood RH Side -(White)
24	1728975	1	INSERT, Lightbar -(Textured)
24	1737032	1	INSERT, Lightbar -(Plain)
25	1727296	1	HEADLIGHT ASSEMBLY

Lift Group - Manual

Note: Unless noted otherwise, use the standard torque specifications

Mfg. No: 2690441

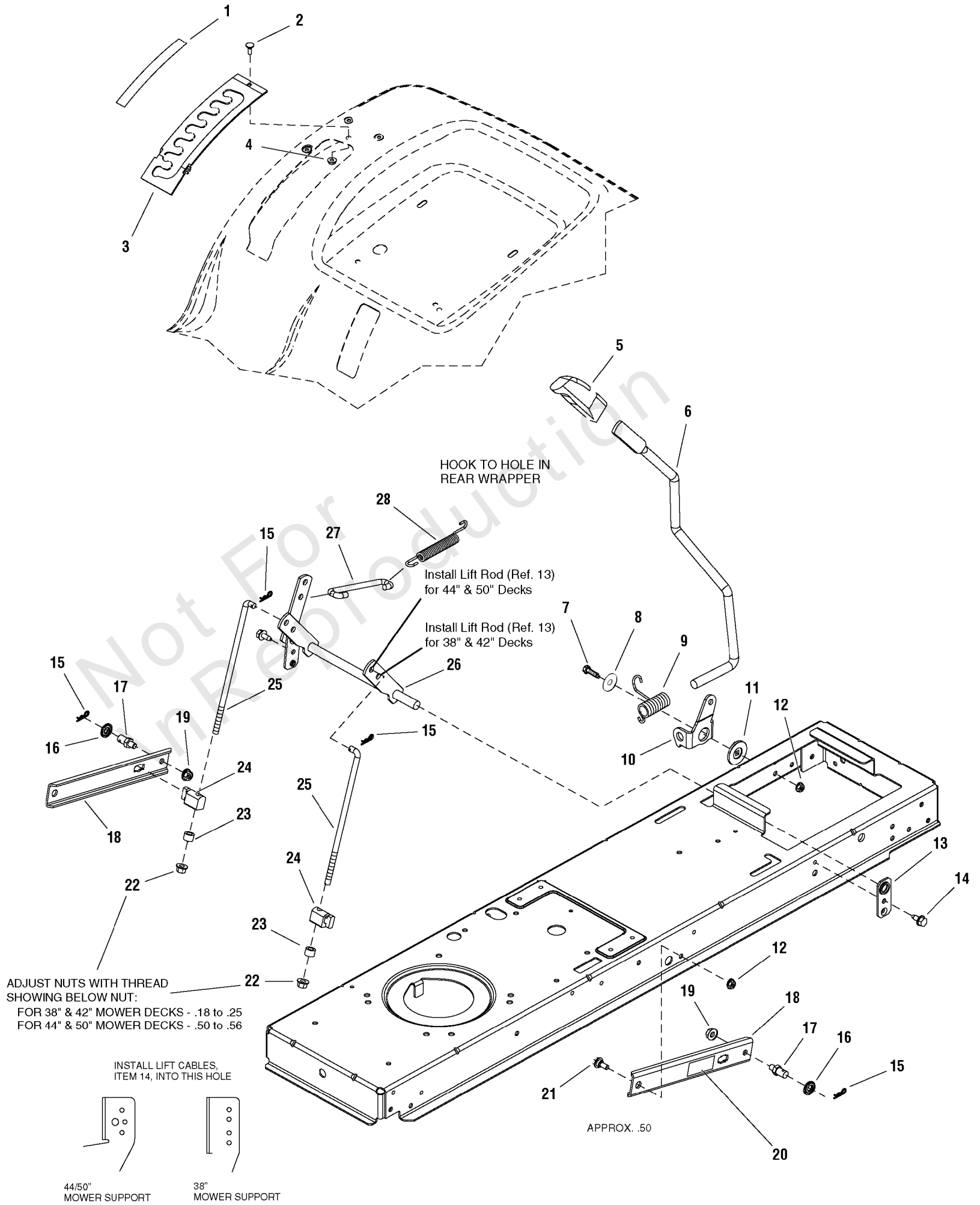

Lift Group - Manual

REF NO	PART NO	QTY	DESCRIPTION
1	1730264	1	DECAL, Height Of Cut
2	1960252	1	BOLT, Carriage, 1/4-20 x 5/8 G5
3	1727985A	1	QUADRANT, Lift Height
4	1930641	1	NUT, Hex Flange Whiz, 1/4-20
5	1722302	1	GRIP
6	1728070	1	ROD, Lift Handle E-Coat, 17.7 LG
7	1921333	1	CAPSCREW, Hex Head, 5/16-18 x 1
8	1960044	1	WASHER, Plain, 21/64 x 1-1/4
9	1729652	1	SPRING, Torsion, 2.12 LG Black
10	1728990A	1	CLEVIS, Lift
11	1727935	1	SPACER, Pivot Powdered Metal
12	1931277	3	NUT, Hex, Flange Whizlock, 5/16-18
13	1727911A	1	PLATE, Bearing
14	1930601	2	SCREW, Taptite, 5/16-18 x 5/8
15	1960074	4	CLIP, Spring
16	1960170	2	WASHER, 1/2
17	2721135	2	PIN, Threaded Shoulder
18	1731417A	2	ARM, Lift Rear 10GA
19	1928352	2	NUT, Hex, Flange, Whizlock, 5/16-18 x 1/2
20	1732070	2	DECAL, CAUTION! Pinch Point
21	1732426	2	BOLT, Shoulder
22	1960687	2	NUT, Hex Flange, ESNA, 3/8-16
23	1656397	2	SPACER (Used on 38" & 42" Mower Decks)
23	1666294	2	SPACER (Used on 44" & 50" Mower Decks)
24	1731894	2	TRUNNION, Powdered Metal
25	1727955	2	ROD, Lower Lift, 10.00 LG
26	1727951A	1	SHAFT ASSEMBLY, Lift
27	1727954	1	ROD, Lift, 5.43 LG
28	1731939	1	SPRING, Extension 5.10 LG Black (Used on 44" & 50" Mower Decks)

Seat Deck & Fuel Tank Group

Note: Unless noted otherwise, use the standard torque specifications

Mfg. No: 2690441

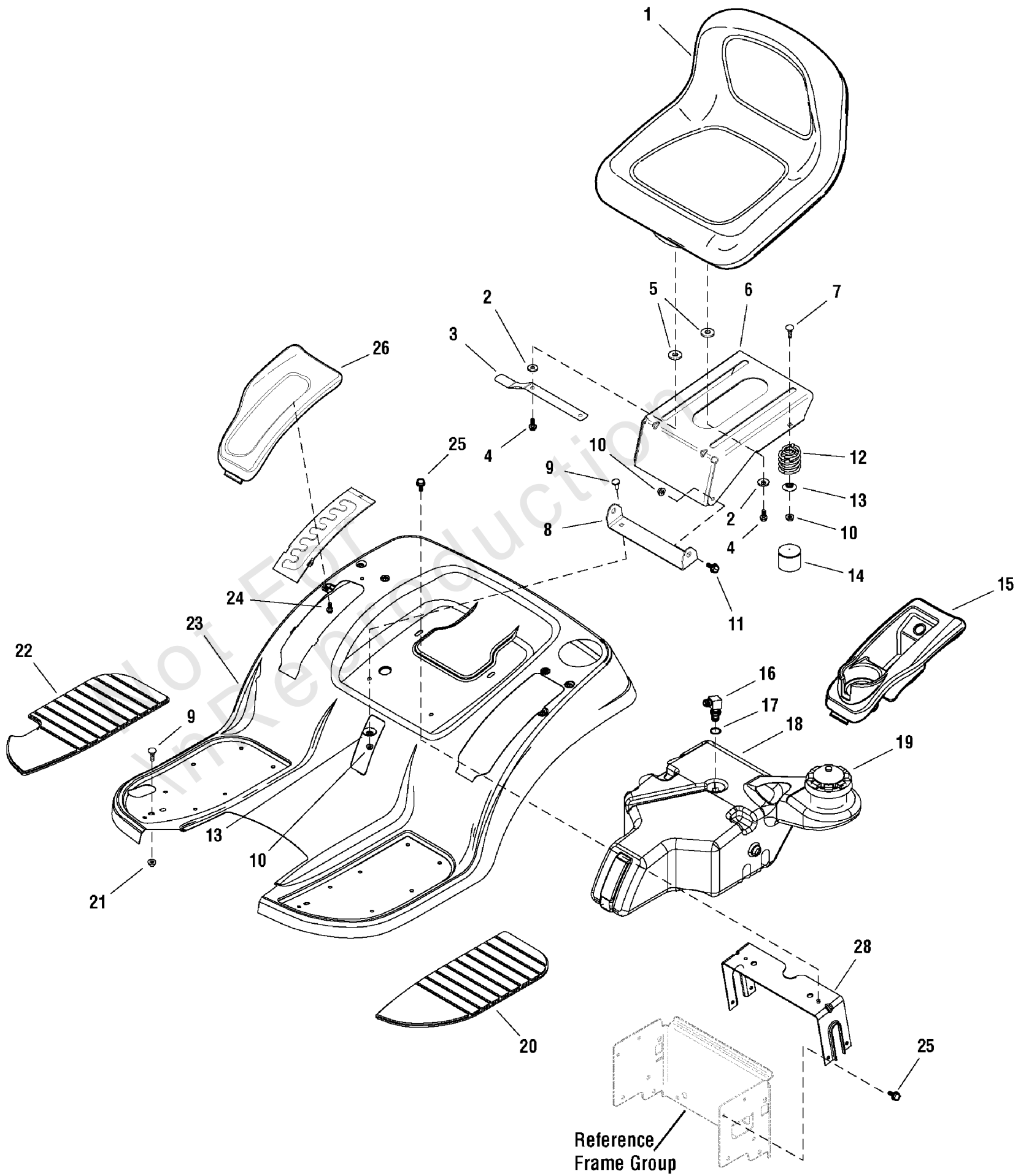

Seat Deck & Fuel Tank Group

REF NO	PART NO	QTY	DESCRIPTION
1	1730158	1	SEAT, Low Back -(Used on 2690577 only)
1	1730159	1	SEAT, Hi Back, Steel Pan
2	1919381	4	WASHER, Plain, 5/16
3	1727268	1	LATCH, Seat 20GA E-Coat
4	1960667	4	CAPSCREW, Hex Head Flange Dog Point, 5/16-18 x 1
5	1731300	4	SPACER, Powdered Metal Yellow
6	1727265A	1	SUPPORT, Seat 12GA
7	1960282	2	BOLT, Carriage, 5/16-18 x 3/4
8	1727266A	1	PIVOT, Seat 10GA
9	1931333	4	BOLT, Carriage, 5/16-18 x 3/4
10	1960686	4	NUT, Hex Flange, 5/16-18 ESNA
11	1729576	2	BOLT, Shoulder 5/16-18 G5
12	1704728	2	SPRING, Compression
13	1709256	4	WASHER, Spring Black
14	1704724	2	COVER, Spring
15	1729001	1	POD, LH Cup Holder
16	1674231	1	ELBOW FITTING
17	1654930	1	BUSHING
18	1727305	1	TANK, Fuel
19	1715917	1	CAP, Gas
20	1728006	1	PAD, Footrest LH
21	1931277	4	NUT, Hex, Flange Whizlock, 5/16-18
22	1728007	1	PAD, Footrest RH
23	1727264D	1	DECK, Seat w/Footrests (Red)
24	1960536	6	SCREW, Hex, Washer Head, Plastite, 1/4-20 x 1/2
25	1930601	6	SCREW, Taptite, 5/16-18 x 5/8
26	1729000	1	POD, RH Lift Quadrant
28	1731310A	1	SUPPORT, Seat Deck

Steering Group

Note: Unless noted otherwise, use the standard torque specifications

Mfg. No: 2690441

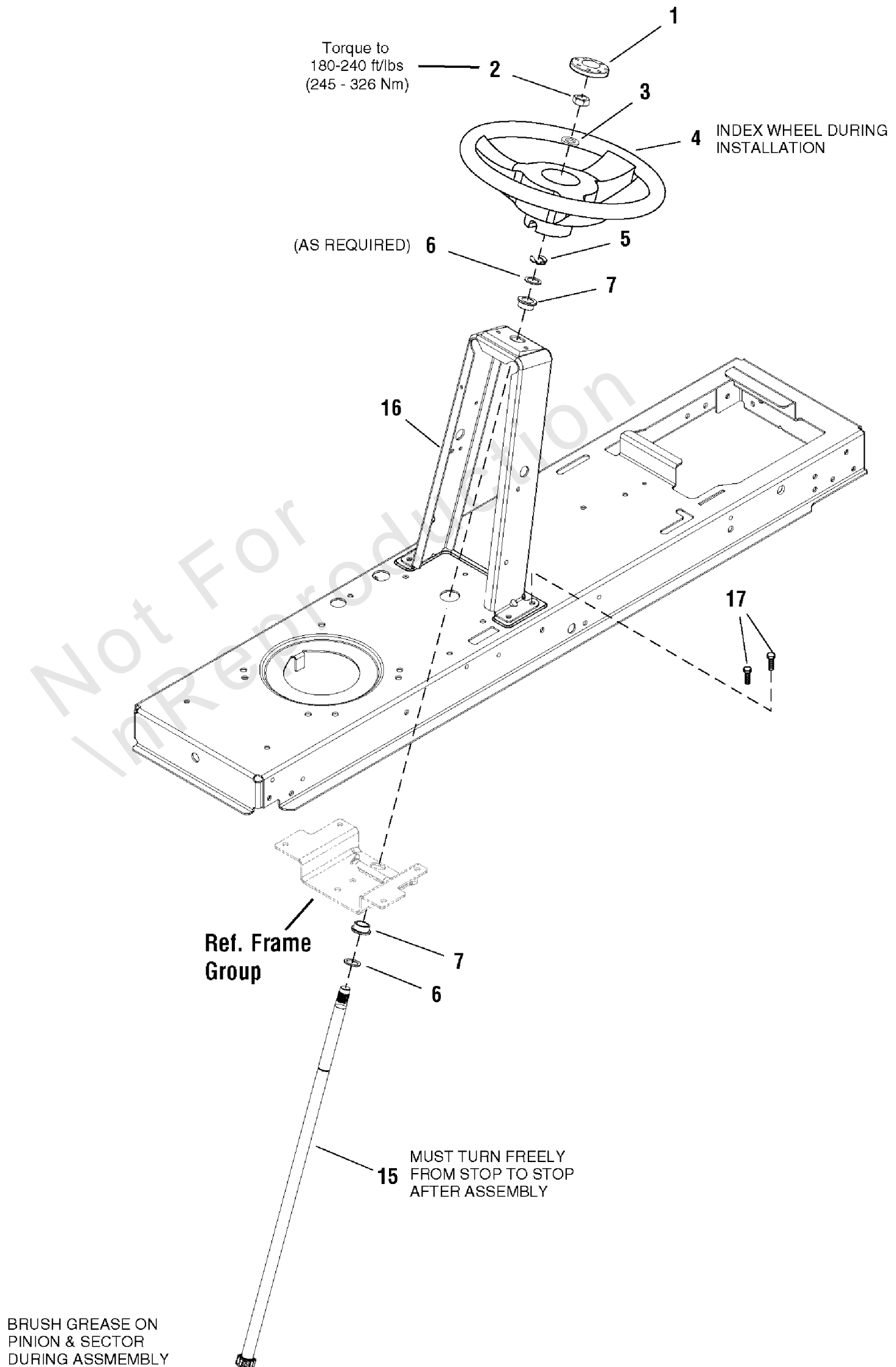

Steering Group

REF NO	PART NO	QTY	DESCRIPTION
1	1725024	1	CAP, Steering Wheel, Plain
2	1960576	1	NUT, Hex Lock, ESNA Light, 5/8-18, Thin
3	1924366	1	WASHER, 5/8
4	1728069	1	STEERING WHEEL, w/Aluminum Insert
5	1611710	1	RING, Klipring Extension
6	1960114	2	WASHER
7	1729665	2	BUSHING, Steering
15	1727813	1	SHAFT, Steering Gear & Spline Yellow
16	1738935A	1	TOWER -(Was 1727260A)
17	1930601	4	CAPSCREW, Hex Washer Head, Taptite, 5/6-18 x 5/8

Not For In Reproduction

Transmission Group - Tuff Torq K46BP

Note: Unless noted otherwise, use the standard torque specifications

Mfg. No: 2690441

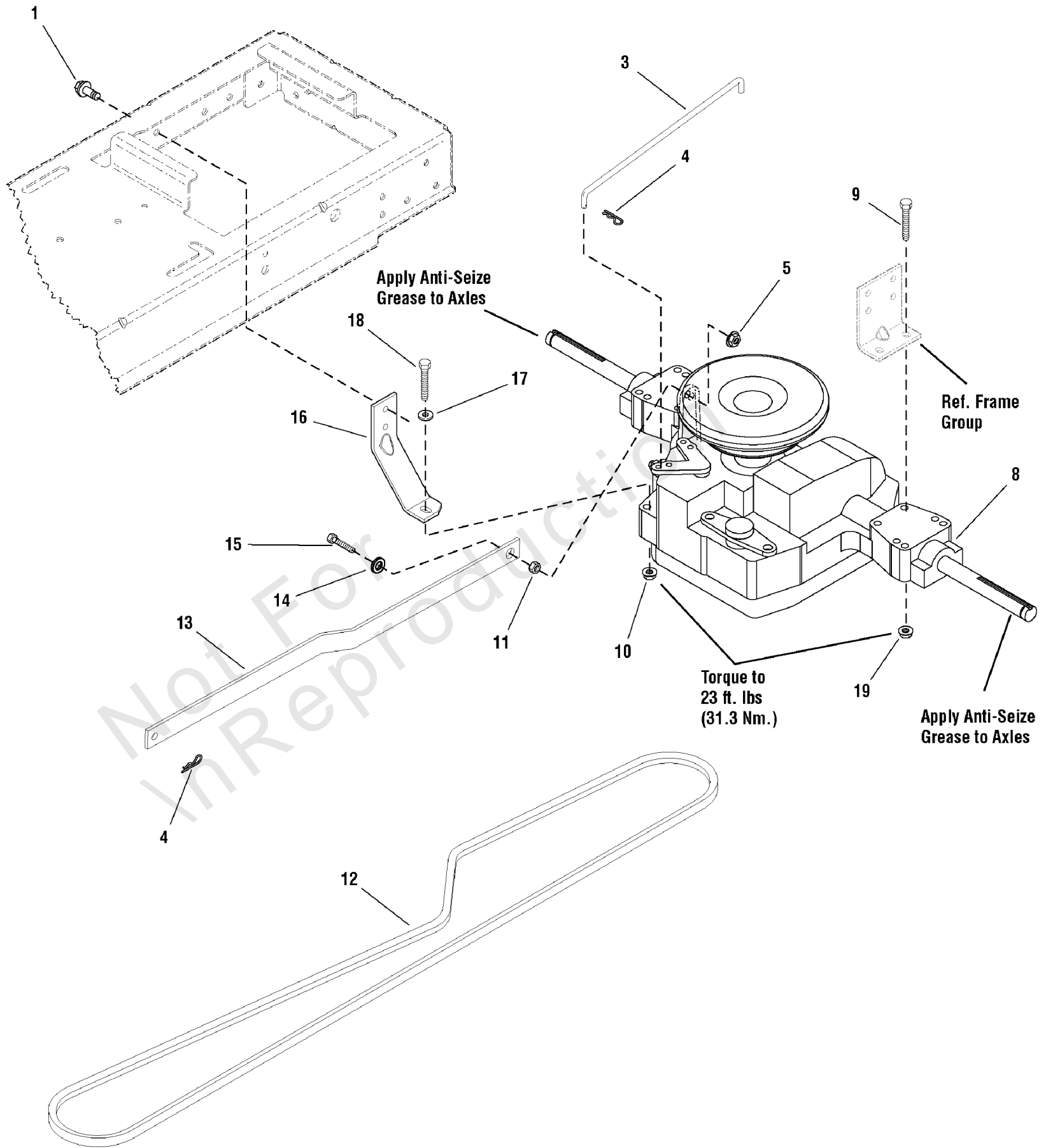

Transmission Group - Tuff Torq K46BP

REF NO	PART NO	QTY	DESCRIPTION
1	1664847	1	CAPSCREW, Hex Head, Taptite, 5/16-18 x 3/4
3	1728120	1	ROD, Bypass, 11.44 LG
4	1722460	2	PIN, Quick
5	1960686	1	NUT, Hex Flange, ESNA, 5/16-18
8	1729588	1	TRANSMISSION ASSEMBLY, K46BP
8	1729589	1	TRANSMISSION ASSEMBLY, K46BL -(Used with 22" Tire Models)
9	1960586	4	SCREW, Hex Head Flange Lock, 5/16-18 x 2-1/2
10	1960686	1	NUT, Hex Flange, ESNA, 5/16-18
11	1666697	1	SPACER
12	1728008	1	V-BELT, Drive Belt, Aramid/Kevlar 89.25" EL HA
13	1727258A	1	ARM, Control
14	1919326	1	WASHER, Flat, 5/16
15	1921333	1	CAPSCREW, Hex Head, 5/16-18 x 1
16	1728043A	1	STRAP, Torque
17	1919381	1	WASHER, Plain, 5/16
18	1922127	1	CAPSCREW, Hex Head, 5/16-18 x 1-3/4
19	1931277	8	NUT, Hex, Flange Whizlock, 5/16-18

Not For Internal Production

Wheels & Tires Group

Note: Unless noted otherwise, use the standard torque specifications

Mfg. No: 2690441

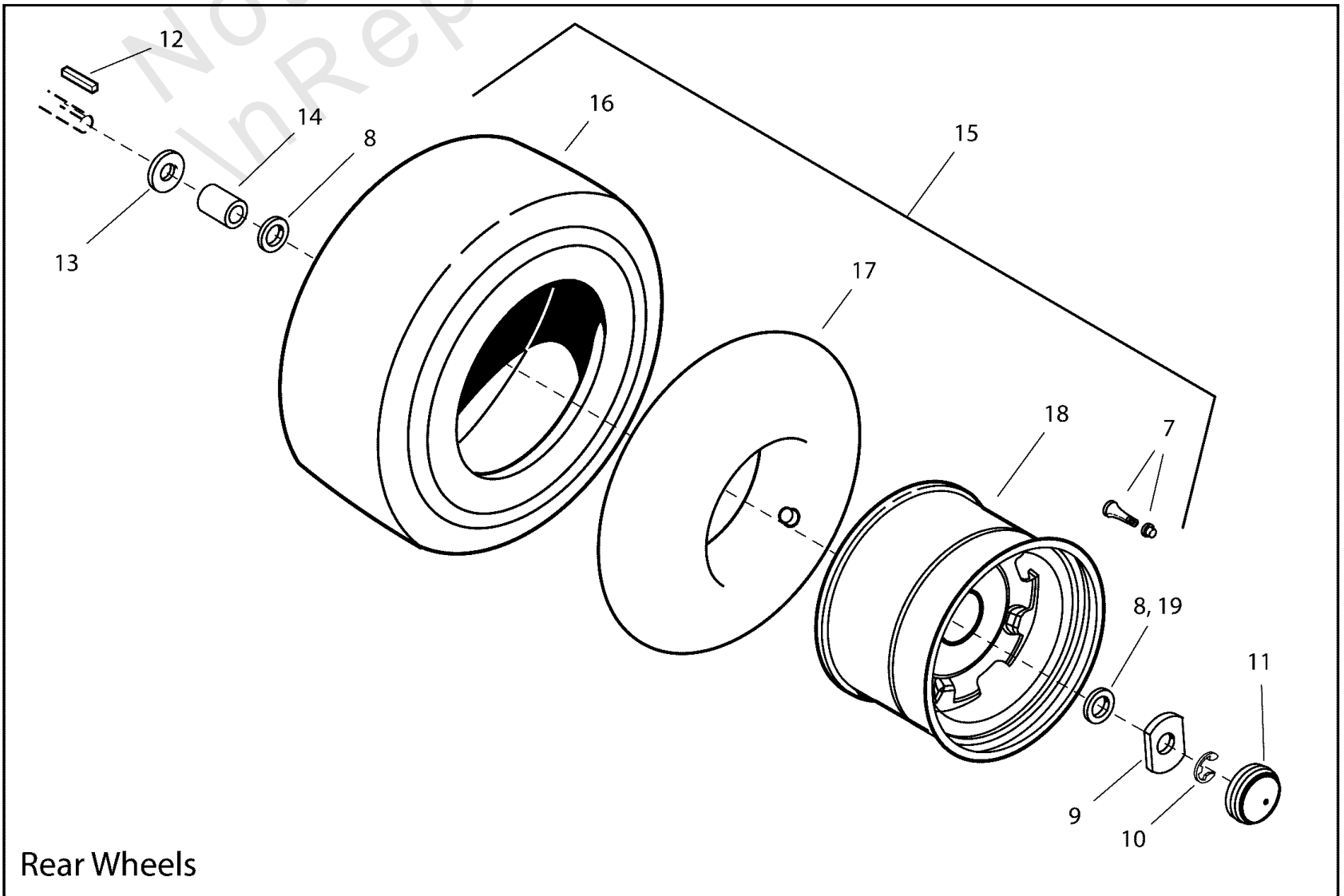
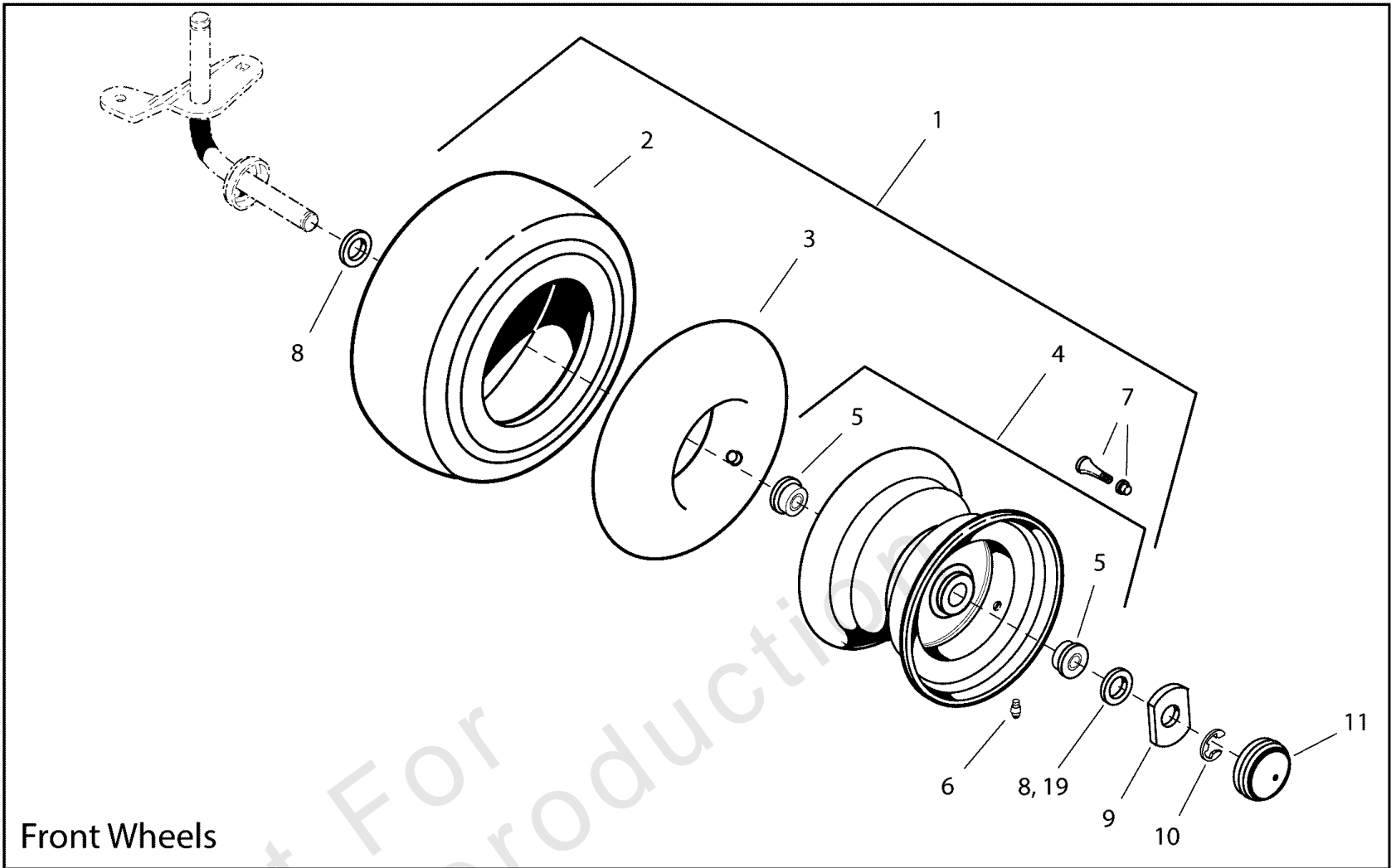

Wheels & Tires Group

REF NO	PART NO	QTY	DESCRIPTION
1	1729708SM	2	WHEEL & TIRE ASSEMBLY, Front 15" X 6.00-6 K358 Tread
2	1731951SM	1	TIRE, 15 X 6.00 - 6 Turf Rider, Kenda
3	1664090SM	1	TUBE, Tire, 4.10/3.50-6
4	1726301SM	1	WHEEL & BUSHINGS ASSEMBLY, Front
5	1752171YP	4	BEARING, 0.755 ID X 1.38 OD X 1.125 Long
6	2812808SM	1	FITTING, Lube, .250-28 Taper Thread
7	7102234SM	2	VALVE STEM & CAP, Air .453 Dia 0.88 Long
8	2860183SM	8	WASHER, .750 (.83 ID X 1.62 OD X .06 Thk) Yel
8	722598	4	WASHER, Flat, 3/4 x 1-1/4 x 16GA -(Model 2690841 & 2690865 Only)
9	1722717SM	4	WASHER, Special Hub Cap, .755 ID, 2.25 X 2.562 OD, .598 Thk, YZ
10	2827794SM	4	KLIPRING, .75 Dia Shaft
10	0011X3MA	4	E-RING, .750 ID, .050 Thk -(Model 2690841 & 2690865 Only)
11	1722676SM	4	HUB CAP, 2.351 D, Grey Poly 1.3H
11	094618MA	4	CAP, Hub -(Model 2690841 & 2690865 Only)
12	1713409SM	2	KEY, Square, .187 X .187 X 3"
12	720258	1	KEY, Square, 3/16 x 3/16 x 2 -(Model 2690841 & 2690865 Only)
13	2860202SM	2	WASHER, .75 (.76 ID X 1.60 OD X .12 Thk) Yel
14	1730181SM	2	SPACER, 0.77 ID x 1-1/4 OD x 1.65 LG PM, Black
15	7101560YP	2	WHEEL & TIRE ASSEMBLY, Rear 20"
15	1732324SM	2	WHEEL & TIRE ASSEMBLY, Rear 22"
16	7101559YP	1	TIRE, Turf 20 X 8.00 - 8 K358 2Ply Tubeless
16	1731953SM	1	TIRE, Turf 22 X 10.00 - 8 Turf Saver TL
16	7101559SM	2	TIRE, Turf 20 X 8.00 - 8 K358 2Ply Tubeless -(Model 2691046 Only)
17	2164247SM	1	TUBE, Tire, Rear, 22 X 8 - 8
17	2173477SM	1	TUBE, Tire, 20 X 8.00 -10
18	7101558YP	1	WHEEL, 7" Wide, 8" Dia., .757 ID Hub
19	722620	4	WASHER, 3/4 x 1-7/8 -(Model 2690841 & 2690865 Only)

Wiring Schematic (1728097)

Note: Unless noted otherwise, use the standard torque specifications

Mfg. No: 2690441

New Regent Briggs & Stratton/Kohler

HARNESS (P/N 1728097)

Cranking Circuit

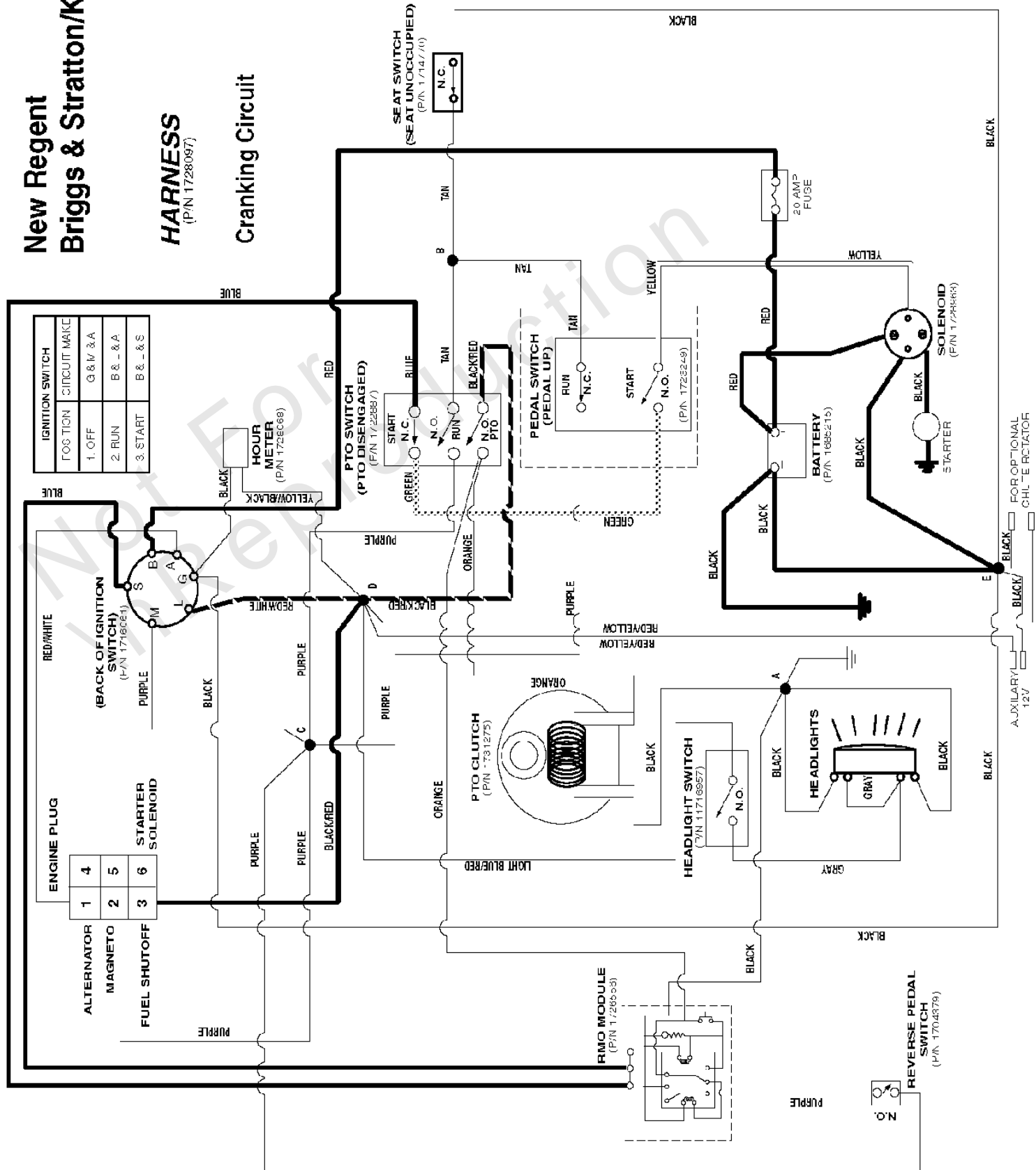

Wiring Schematic (1728097)

REF NO	PART NO	QTY	DESCRIPTION
	-----		Wiring Schematic (for 1728097 Harness)

Not For In Reproduction

Hardware Identification & Torque Specifications

Torque Specification Chart								
FOR STANDARD METRIC MACHINE HARDWARE (Tolerance ± 20%)								
Property Class	5.6		8.8		10.9		12.9	
	Class 5.6		Class 8.8		Class 10.9		Class 12.9	
Size Of Hardware	in/lbs	Nm.	in/lbs	Nm.	in/lbs	Nm.	in/lbs	Nm.
	ft/lbs		ft/lbs		ft/lbs		ft/lbs	
M3	5.88	.56	13.44	1.28	19.2	1.80	22.92	2.15
M4	13.44	1.28	30.72	2.90	43.44	4.10	52.56	4.95
M5	26.4	2.50	60.96	5.75	5.97	8.10	7.15	9.7
M6	44.64	4.3	7.3	9.9	10.3	14	12.1	16.5
M7	5.2	7.1	12.1	16.5	16.9	23	19.9	27
M8	7.7	10.5	17.7	24	25	34	29	40
M10	15	21	35	48	50	67	59	81
M12	26	36	61	83	86.2	117	103	140
M14	42	58	101	132	136	185	162	220
M16	64	88	147	200	210	285	250	340
M18	89	121	202	275	287	390	346	470
M20	126	171	290	390	405	550	486	660
M22	169	230	390	530	559	745	656	890
M24	217	295	497	375	708	960	840	1140
M27	320	435	733	995	1032	1400	1239	1680
M30	435	590	995	1350	1401	1900	1681	2280
M33	590	800	1349	1830	1902	2580	2278	3090
M36	759	1030	1740	2360	2441	3310	2935	3980
M39	988	1340	2249	3050	3163	4290	3798	5150

Torque Specification Chart						
FOR STANDARD MACHINE HARDWARE (Tolerance ± 20%)						
Hardware Grade	No Marks		SAE Grade 5		SAE Grade 8	
	SAE Grade 2		SAE Grade 5		SAE Grade 8	
Size Of Hardware	in/lbs	Nm.	in/lbs	Nm.	in/lbs	Nm.
	ft/lbs		ft/lbs		ft/lbs	
8-32	19	2.1	30	3.4	41	4.6
8-36	20	2.3	31	3.5	43	4.9
10-24	27	3.1	43	4.9	60	6.8
10-32	31	3.5	49	5.5	68	7.7
1/4-20	66	7.6	8	10.9	12	16.3
1/4-28	76	8.6	10	13.6	14	19.0
5/16-18	11	15.0	17	23.1	25	34.0
5/16-24	12	16.3	19	25.8	29	34.0
3/8-16	20	27.2	30	40.8	45	61.2
3/8-24	23	31.3	35	47.6	50	68.0
7/16-14	30	40.8	50	68.0	70	95.2
7/16-20	35	47.6	55	74.8	80	108.8
1/2-13	50	68.0	75	102.0	110	149.6
1/2-20	55	74.8	90	122.4	120	163.2
9/16-12	65	88.4	110	149.6	150	204.0
9/16-18	75	102.0	120	163.2	170	231.2
5/8-11	90	122.4	150	204.0	220	299.2
5/8-18	100	136	180	244.8	240	326.4
3/4-10	160	217.6	260	353.6	386	525.0
3/4-16	180	244.8	300	408.0	420	571.2
7/8-9	140	190.4	400	544.0	600	816.0
7/8-14	155	210.8	440	598.4	660	897.6
1-8	220	299.2	580	788.8	900	1,244.0
1-12	240	326.4	640	870.4	1,000	1,360.0

The guides and ruler furnished below are designed to help you select the appropriate hardware.

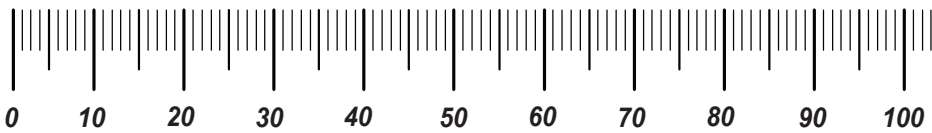

Nut, M8

Thread Diameter (mm)

Inside Diameter (in) Threads per inch

Nut, 1/2-16



Screw, M8- 1.25 x 25

Thread Diameter (mm) Distance between threads (mm) Body Length (mm)

Body Diameter Threads per inch Body Length (in)

Screw, 1/2- 16 x 2



Standard Hardware Sizing

When a washer or nut is identified as 1/2" (M8), this is the *Nominal size*, meaning the *inside diameter* is 1/2 inch (8mm metric thread diameter); if a second number is present it represents the *threads per inch* (distance between threads).

When bolt or capscrew is identified as 1/2 - 16 x 2" (M8 - 1.25 x 50), this means the *Nominal size*, or body diameter is 1/2 inch (8mm metric thread diameter), the second number, 16, represents the *threads per inch*, (*distance between threads*). The final number is the body length of the bolt or screw, 2 inches (50mm).

NOTES

- These torque values are to be used for all hardware excluding: locknuts, self-tapping screws, thread forming screws, sheet metal screws and socket head setscrews.
- Recommended seating torque values for locknuts:
 - for prevailing torque locknuts - use 65% of grade 5 torques.
 - for flange whizlock nuts and screws - use 135% of grade 5 torques.
- Unless otherwise noted on assembly drawings, all torque values must meet this specification.

Common Hardware Types

Hex Head Capscrew



Washer



Carriage Bolt



Hex Nut

Wrench & Fastener Size Guide

1/4" Bolt or Nut Wrench—7/16"	5/16" Bolt or Nut Wrench—1/2"	3/8" Bolt or Nut Wrench—9/16"	7/16" Bolt or Nut Wrench (Bolt)—5/8" Wrench (Nut)—11/16"	1/2" Bolt or Nut Wrench—3/4"
M6 Bolt or Nut Wrench—10mm	M8 Bolt or Nut Wrench—13mm	M10 Bolt or Nut Wrench—17mm	M12 Bolt or Nut Wrench—19mm	M14 Bolt or Nut Wrench—22mm

