

Parts Manual for  
**SNAPPER**<sup>®</sup>

**21" STEEL DECK WALK BEHIND  
COMMERCIAL MOWER  
SERIES 20**

Model No.	Description
7800968-00	CRP218520
7800968-01	CRP218520

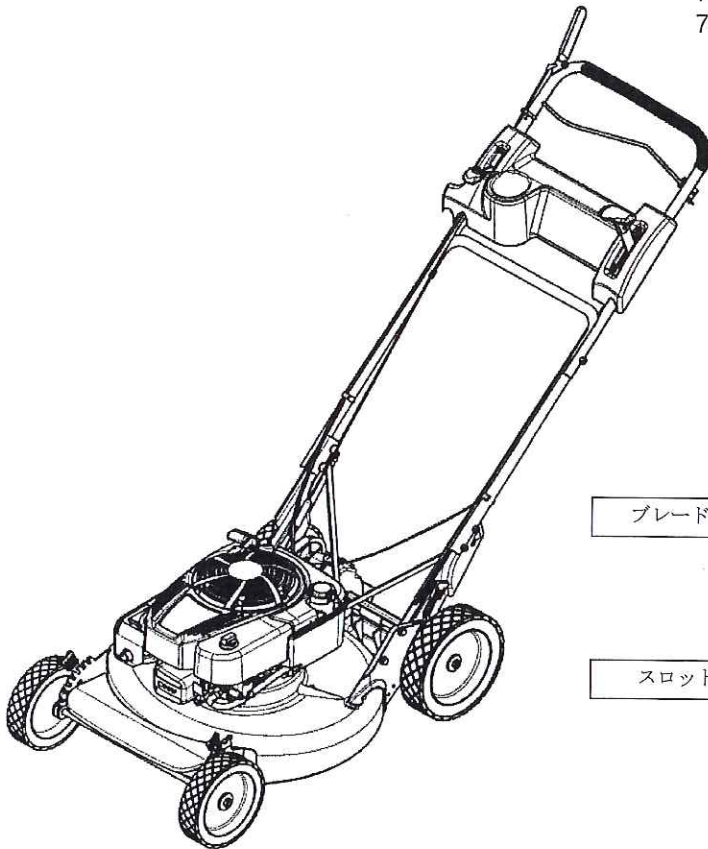

ブレードコントロールレバーがハンドル上側

スロットルレバー無し



Briggs & Stratton Yard Power Products Group  
535 Macon Road  
McDonough, GA, 30253 U.S.A.  
800-935-2967

Manual No. 1759770  
Revision: A 7/28/2015

Not for  
Reproduction

<b>PAGE</b>	<b>GROUP</b>
4	Handle Group
6	Wheels, Brackets & Latches
8	Deck, Engine & Blade Group
10	Drive System, Self Propelled
14	Transmission Assembly
16	Decal Group

Not for  
Reproduction

# Handle Group

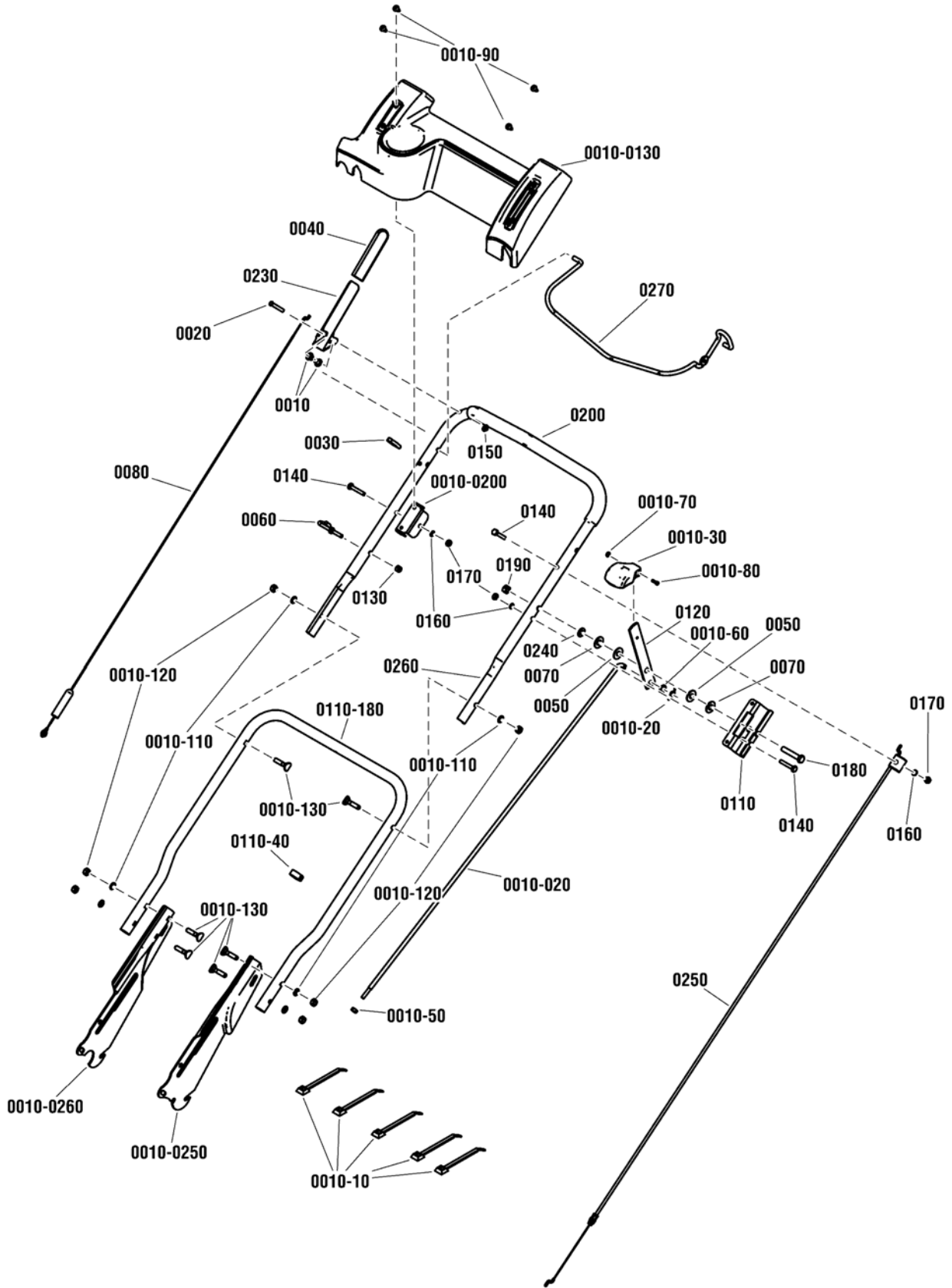

Item	Part No	Qty	Description
0010	7014343YP	2	BUSHING, Flanged, .27 ID, Nylon, Black
0010-10	7024641YP	5	WIRE TIE, 5.5" L
0010-20	704030	1	PIN, 5/16 X 1.044, Self-Locking Cotter, Zinc/Clear
0010-30	7075182YP	1	KNOB, Shift, Red
0010-50	703461	1	NUT, 1/4-28 Hex, GR5, Zinc/Clear
0010-60	703350	1	WASHER, 5/16, Flat SAE, Zinc/Clear
0010-70	703460	1	NUT, #8-32, Hex, Zinc/Clear
0010-80	703351	1	SCREW, #8-32 X 0.50, Machine Fillister Head, Zinc/Clear
0010-90	703961	4	SCREW, 1/4-20 X .550, T-30 Pan Head Torx, Self-Tap
0010-110	7090391SM	6	WASHER, 5/16, Internal Lock, Zinc/Clear
0010-120	703465	6	NUT, 5/16-18, GRB, Zinc/Clear
0010-130	704063	6	BOLT, 5/16-18 X 1.50, Carriage Head, Short Neck, ZC/CL
0010-020	7074133YP	1	ROD, Speed Control (35.5" L, 1/4-28 thread)
0010-013	7106275YP	1	PANEL, Dash, ES W/O Throttle
0010-020	7106274BMYP	1	BRACKET, Panel Mount, Black
0010-025	7033985AYP	1	HANDLE, Lower, ADJ, LH
0010-026	7033986AYP	1	HANDLE, Lower, ADJ, RH
0020	704031	1	PIN, 1/4 X 1.5", Clevis, ZC/CL
0030	7026219YP	1	CLAMP, 7/8" Double Cable
0040	7028407YP	1	GRIP, International Symbol, 4.6" Black
0050	704004	2	WASHER, .406 ID X 1.0 OD X .063 Thk, Flat Nylon
0060	7028488MA	1	GUIDE, 1/4-20, Rope, CL/ZC
0070	703964	2	WASHER, Flat
0080	7034604YP	1	CABLE, Clutch Control, 41.25" L
0110	7074003YP	1	BRACKET, Shift, Black Zinc
0110-40	7023813SM	1	CLIP, Wiring Harness
0110-180	7106232AYP	1	HANDLE, Middle, Black
0120	7074113YP	1	LEVER, Shift
0130	703232	1	NUT, 1/4-20, Nylock, GR A, Zinc/Clear
0140	703234	3	SCREW, 1/4-20 X 1.5, Hex Head Cap, GR5, ZC/CL
0150	704005	1	NUT, 1/4, Push, Zinc/Clear
0160	703462	3	WASHER, 1/4 Internal Tooth Lock, YZ
0170	703127	3	NUT, Hex, 1/4-20, GR5
0180	703589	1	CAPSCREW, Hex Head, 3/8-16 x 2, G5
0190	703347	1	NUT, Hex Center Lock, 3/8-16, G5
0200	7023810YP	1	FOAM GRIP, 18.75"
0230	7074473AYP	1	HANDLE, Clutch
0240	704006	1	WASHER, 3/8" ID x 3/4" OD, Belleville, Zinc/Clear
0250	7106257YP	1	CABLE, OPC, 50.56" Long, Z Ends, Snap-in, for Over-the-Top Bail
0260	7106258AYP	1	HANDLE, Upper, 17.53" Wide, Black
0270	7106255AYP	1	BAIL, OPC, Over-the-Top, Black

Footnotes:

**Wheels, Brackets & Latches**

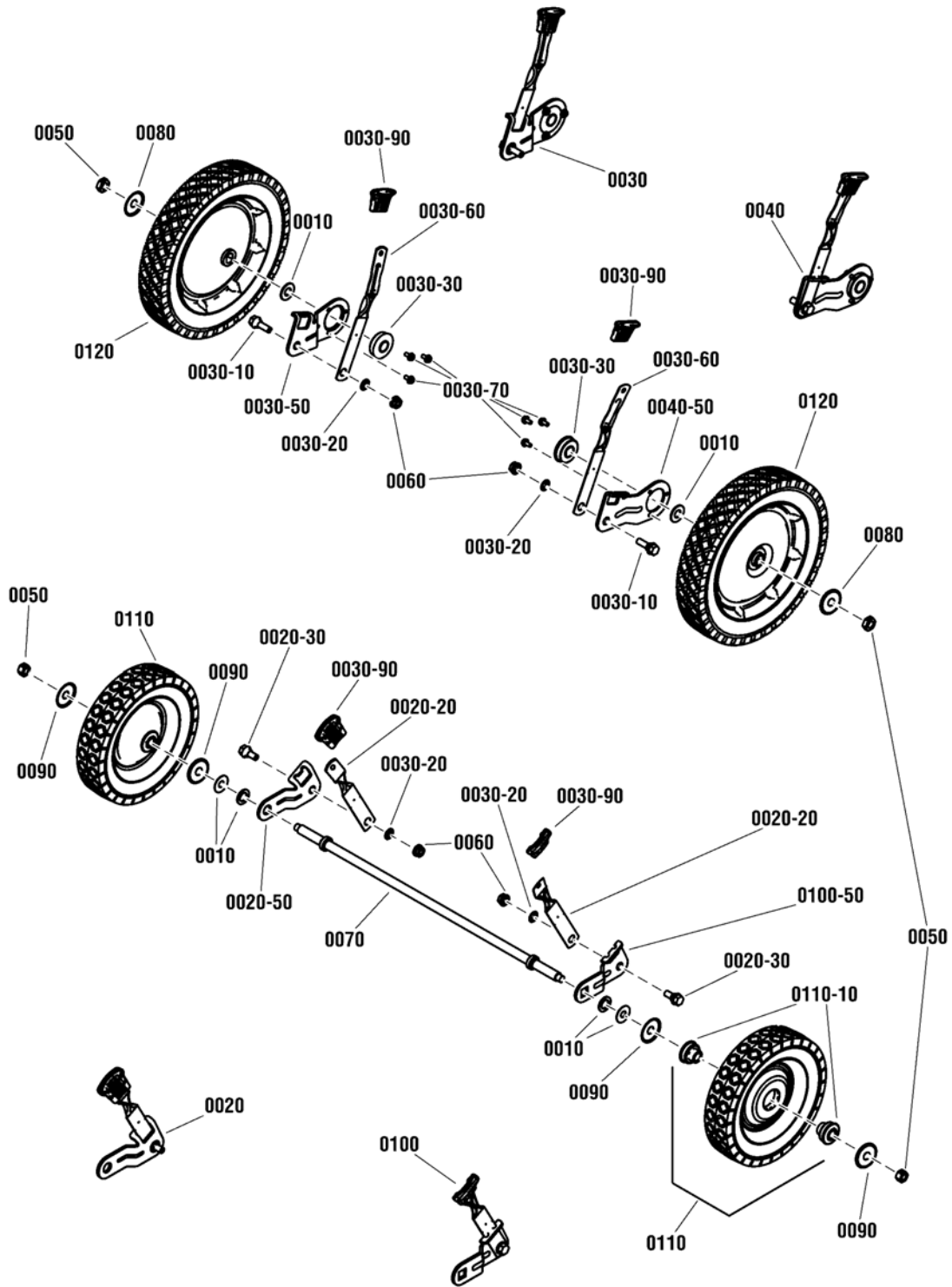

<b>Item</b>	<b>Part No</b>	<b>Qty</b>	<b>Description</b>
0010	703964	6	WASHER, 7/16" ID, 1" OD, .060 Thk, Flat, ZC/CL
0020	7600180YP	1	KIT, Front Wheel Arm Assembly, RH
0020-20	7012325YP	2	LATCH, Height
0020-30	703839	2	BOLT, 5/16-18 X .750, Hex Washer Head Shoulder, Zinc/Clear
0020-50	7031017YP	1	WHEEL ARM, Front, Round Hole, RH, Clear
0030	7054246YP	1	ASSEMBLY, Wheel Arm, Long, RR
0030-10	703840	2	BOLT, 5/16-18 X 1.0, Hex Washer Head .435 Dia. Shoulder, ZC/CL
0030-20	703297	4	RETAINER, 5/16 X .625, Push Nut, GR 5, Zinc/Clear
0030-30	7012312YP	2	BEARING, 9/16" ID
0030-50	7032722YP	1	ARM, Wheel, Right Rear, Zinc/Clear
0030-60	7035717YP	2	LATCH, Height Adjusting, (long)
0030-70	703967	6	SCREW, #10-32 x 3/8, Torx Hex Washer Head Self-Tap, ZC/CL
0030-90	7103793YP	4	GRIP, Height Latch, Black
0040	7054247YP	1	ASSEMBLY, Wheel Arm, Left Rear, Long
0040-50	7032723YP	1	ARM, Wheel, Left Rear, Zinc/Clear
0050	703348	4	NUT, 7/16-20, Hex Jam Center Lock, GR B, Zinc/Clear
0060	703409	4	NUT, 5/16-18, Serated Lock Flange, GR5, Zinc/Clear
0070	7021119YP	1	AXLE, V21
0080	7031960YP	2	HUBCAP, Rear
0090	7031121YP	4	HUBCAP, Front
0100	7600179YP	1	ASSEMBLY, Front Wheel Arm, LH
0100-50	7031016YP	1	WHEEL ARM, L.H. Front (Square Hole)
0110	7035727YP	2	WHEEL, 8 x 1.75 - Steel - D - Gray
0110-10	7011125YP	4	BEARING, 7/16" ID, Ball, Front Wheel
0120	7035726YP	2	WHEEL, 10 x 1.75, Steel-D, (Self Propelled) - Gray

**Footnotes:**

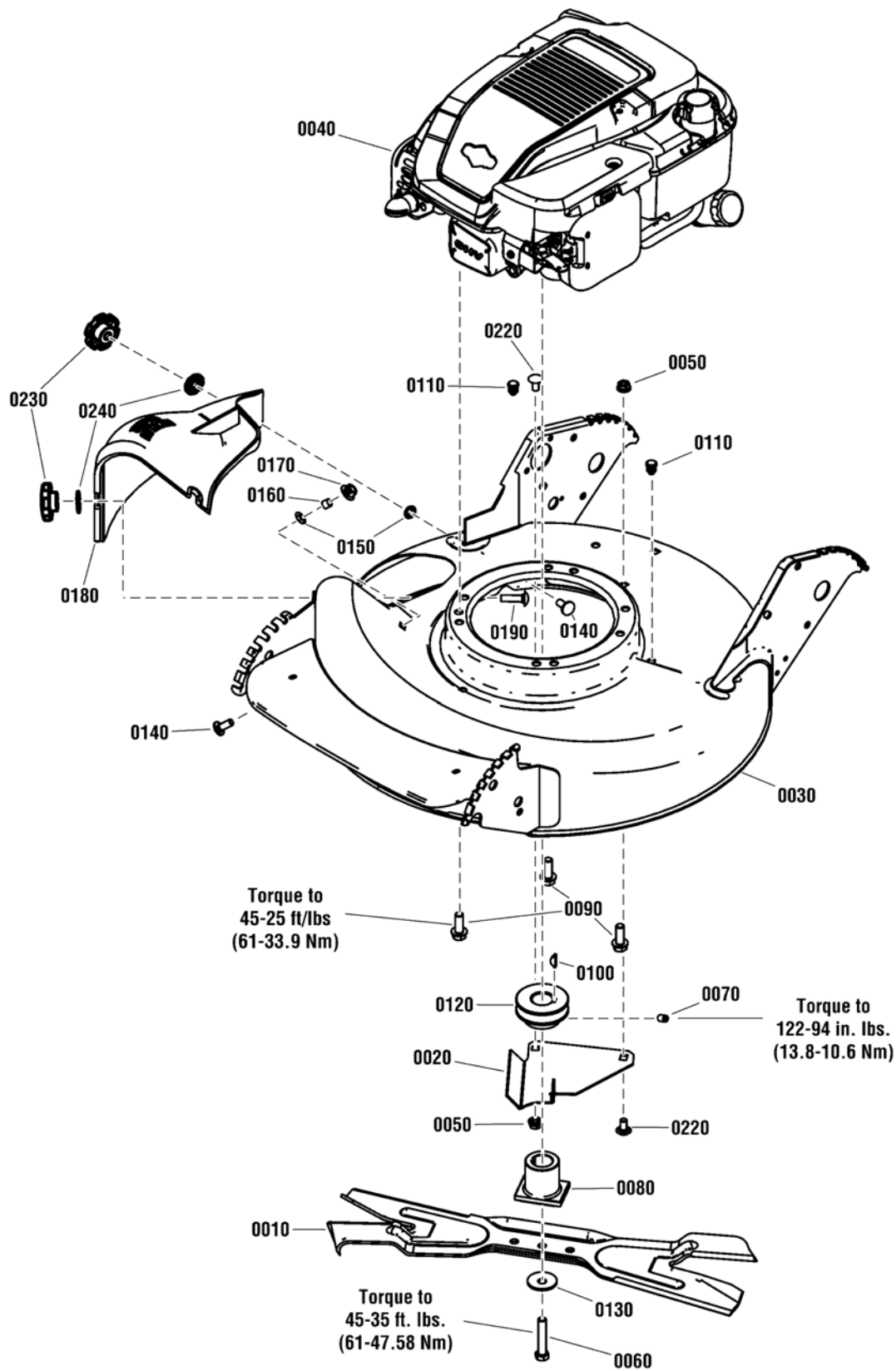



<b>Item</b>	<b>Part No</b>	<b>Qty</b>	<b>Description</b>
0010	7026407AYP	1	BLADE, 21" Ninja
0020	7074568YP	1	COVER, Belt, Zinc/Clear
0030	7400026DYP	1	WELDMENT, DECK, 21" AIR, Non-Adj.
0040	121Q42-0016-F1	1	* ENGINE, B&S PRO, 8.5TP, 121Q42-0016-F1 7106312
0050	703409	2	NUT, 5/16-18, Serated Lock Flange, GR5, Zinc/Clear
0060	703999	1	SCREW, 3/8-24 X 2, Hex Head Cap, GR5
0070	704003	1	SCREW, 5/16-18 X .50, Hex Socket Head, Phosp/Oil
0080	7101414YP	1	HUB, Blade, 21 WBM, 25MM ID, 2 Position
0090	704000	3	SCREW, 3/8-16 X 1.0, Hex Washer Self-Tap, ZC/CL
0100	7091214YP	1	KEY, HI-PRO, .1875X.656, #605
0110	7046780SM	2	PLUG, Hole, .44" OD, Polyethylene
0120	7105122YP	1	PULLEY, Engine (25mm I. D. x 2-1/8 O.D.)
0130	703963	1	WASHER, 13/32x1-13/32" Dia. Cone
0140	703185	2	BOLT, 5/16-18 x 3/4, Carriage, Short Neck, G5, Zinc/Clear
0150	703297	2	RETAINER, 5/16 X .625, Push Nut, GR 5, Zinc/Clear
0160	7024340SM	1	SPACER, .375 OD X .316 ID X .305 L
0170	704001	1	NUT, 5/16-18 Large Flange Center Lock, ZC/CL
0180	7029149YP	1	COVER, Mulching, 21" Deck
0190	704002	1	BOLT, 5/16-18 X 1.125, Carriage, ZC/CL
0220	703447	2	BOLT, 5/16-18 X .625, Carriage, GR5, Zinc/Clear
0230	7101022YP	2	KNOB, (5/16-18 X 1/2 Thread) Fluted
0240	703936	2	WASHER, .325 ID X .850 OD X .041 Thk, Internal External Lock, Type A, ZC/CL

Not for  
Reproduction

**Footnotes:**

NOTE: \* Purchase engine & engine parts from engine service outlets.



## Drive System, Self Propelled

Item	Part No	Qty	Description
0010	704008	1	O-RING, 1.0 ID X 1.25 OD X 0.125 Thk
0020	7012114SM	1	BUSHING, Differential
0030	704009	1	RING, Split, .68 x .93 x .44 (Black)
0040	7029025YP	1	SPRING, Extension, .58 x 3.2
0050	7031809YP	1	HOLDER, Bearing (Outer Half), ZC/CL
0060	7046784YP	1	BELT, Engine Drive (Stretch)
0070-10	703970	1	SPACER, .623 OD x .328 ID x .151 L
0070-20	7015753YP	2	BALL JOINT, 1/4-28
0070-30	7073913YP	1	BELL CRANK, Black Zinc
0070-40	7074145YP	1	LINK, Transfer (1/4-28 thread)
0070-50	703462	3	WASHER, 1/4 Internal Tooth Lock, YZ
0070-60	703461	3	NUT, 1/4-28 Hex, GR5, Zinc/Clear
0070-70	703409	7	NUT, 5/16-18, Serated Lock Flange, GR5, Zinc/Clear
0070-80	7900022YP	3	WASHER, Flat, 7/8 x 21/64
0070-100	703408	1	SCREW, 5/16-18 x 7/8 Hex Head Cap, GR 5, Zinc/Clea
0070-110	7073822BMYP	1	BRACKET, Bell Crank
0080-10	703971	1	BUSHING, 0.385 ID X 0.925 OD X 1.018 Thk, ZC/CL
0080-20	7073528YP	1	DRIVE DISC, Steel
0090-10	703836	1	STUD, 3/8-24 X 2.38, Single End, ZC/CL
0090-20	7012122YP	1	SPRING, Clutch, Adjustable Tension
0090-30	7012126YP	1	SPRING, Idler Torsion
0090-40	703946	1	WASHER, .390 ID X .720 OD X .054 Thk, Flat, ZC/CL
0090-50	7019383YP	1	PULLEY, Poly-V, 2.0" OD, Steel
0090-70	7028014YP	1	BALL BEARING, Spherical O.D., .38 I.D.
0090-80	7031873YP	1	HOLDER, Bearing (Inner Half)
0090-90	7051921YP	1	ASSEMBLY, Clutch Idler
0090-020	7012124YP	1	PULLEY, Flat Idler, .25 ID, 2.25 OD
0090-040	703972	1	NUT, 1/4-28 Hex Top Lock, GR 5, BZ
0090-050	703828	1	SCREW, 1/4-28 x 1-3/8" Hex Head Cap, Grade 5, CZ/CL
0090-060	7600173YP	1	KIT, Idler Arm, Bushing & Spacer Assembly
0090-002	7032832AYP	1	ARM, Clutch Idler
0090-003	703974	1	SPACER, Idler Arm (.500 ID x .970 Long), ZC/CL
0090-110	703930	3	WASHER, 3/8 Internal Tooth Lock, BZ
0090-120	703312	1	PIN, 3/32 X 3/4, GR5, Cotter, Zinc/Clear
0090-150	7072284YP	1	SHAFT, Hex (3/8-24 thread, one end)
0090-160	703458	1	NUT, 3/8-24 Hex Center Lock, GR B, YZ
0110	7600109YP	1	ASSEMBLY, Driven Disc, Short, Commercial
0110-10	703975	1	RETAINING RING, 3/4" ID, ZC/CL
0110-20	704059	1	Disc, Rubber Driven, 3" ID
0110-30	703837	1	STUD, 3/8-24 X 4.5, Plate, ZC/CL
0110-40	7029027YP	1	BEARING, 3/4" ID, Ball, Commercial
0110-50	7031013YP	1	PLATE, Driven Tire Side
0110-60	7061276YP	1	KIT, Bushing & Hub Assembly
0110-70	703590	1	WASHER, 3/8 (.406 X .816 X .65), Flat, Zinc/Clear

### Footnotes:



<b>Item</b>	<b>Part No</b>	<b>Qty</b>	<b>Description</b>
0110-90	704060	7	SCREW, 10-24 x 1/2" Hex Washer Self-Tap, Torx, ZC/CL
0110-100	704061	4	SCREW, #10-32 X 1/4,Hex Washer, Self-Tap, ZC/CL
0110-120	7300977BMYP	1	THRUST PLATE, Short, Black
0110-130	703895	2	NUT, 3/8-24, Hex, Grade 5, YZ
0120	703350	1	WASHER, 5/16, Flat SAE, Zinc/Clear
0130	MT910828MA	1	BOLT,5/16-24 X 1.00,HEX,ZC/CL
0150	704130	2	SCREW, 1/4-20 X .500, Hex HD, Self-Tap, Zinc/Clear
0160	703940	1	WASHER, 0.445 ID X 0.780 OD X 0.025 Thk, Wave, ZC/CL
0160-20	7012354YP	1	BELT, Poly-V, Kevlar, V21
0160-30	7012616YP	1	SUPPORT, Foot Guard
0160-60	7029008YP	1	GUARD, Rear Foot, 21"
0160-90	703978	1	BOLT, Rond Head, 1/4-20 x 1/2
0160-100	703127	1	NUT, Hex, 1/4-20, GR5
0160-110	7090391SM	1	WASHER, 5/16, Internal Lock, Zinc/Clear
0160-120	1753983YP	1	SCREW, 5/16-18 x 5/8 Truss Head Torx
0160-150	7034179BMYP	1	LINK, DIFFERENTIAL, COMM
0170	703354	3	SCREW, 5/16-18 X .750, Flanged Whiz-Lock, GR5
0180	703947	1	NUT, 5/16-18 X .625, Weld, ZC/CL
0190	703447	1	BOLT, 5/16-18 X .625, Carriage, GR5, Zinc/Clear
0200	703896	1	NUT,5/16-24,HEX CNTRLCK,GR B,ZINC/CLEAR
0220	703167	1	SCREW, Taptite, 5/16-18 x 1-1/4
0230	703457	1	NUT,3/8-16,FIN HEX,GR 5,ZINC/CLEAR
0240	1501125MA	1	PIN, 1/16 X 0.50 COT, GR 5 ZINC/CLEAR
0250	7033985AYP	1	HANDLE, LOWER, ADJ, LH
0260	7033986AYP	1	HANDLE, LOWER, ADJ, RH
0270	7052987BMYP	1	DECK BRKT. ASSY, P21S ECOAT
0270-10	703973	4	BUSHING, Flanged, .381 x .625 x .62, Metal, CZ/CL
0270-20	703941	1	SPACER,0.500IDX0.650ODX1.750THK,ZC/CL
0270-30	7033774YP	1	BRKT, DECK, P21S
0290	7046707BMYP	2	BRACE, HANDLE ECOAT

**Footnotes:**



<b>Item</b>	<b>Part No</b>	<b>Qty</b>	<b>Description</b>
0020	7012354YP	1	BELT, Poly-V, V21
0030	7012616YP	1	SUPPORT, Foot Guard
0040	----		GREASE, Darina 00 (Not Shown, Use 4oz. Max)
0050	703931	1	PLUG, Transmission Housing, .702 OD
0060	7029008YP	1	GUARD, Foot
0090	703978	1	BOLT, 1/4-20 X 1/2, Carriage, GR5 YZ
0100	703127	1	NUT, 1/4-20, G5 Zinc/Clear
0110	7090391SM	1	WASHER, 5/16, Internal Lock, Zinc/Clear
0120	1753983YP	1	SCREW, 5/16-18 x 5/8 Truss Head Torx
0130	703462	1	WASHER, 1/4 Internal Tooth Lock, YZ
0140	7053943YP	1	ASSEMBLY, Transmission, 21P
0140-10	7011110YP	4	SHAFT, Pinion, .471 OD, 1.5" Long
0140-40	7011774YP	1	GASKET, V21
0140-50	7012495YP	1	GEAR, 46T, V21
0140-60	703933	4	SPACER, .700 OD x .480 ID x .380 L, ZC/CL
0140-80	7019213YP	1	PULLEY, Poly-V (3.5 O.D.)
0140-90	7021115YP	4	GEAR, Pinion (12 Tooth, .625 Thick)
0140-100	7031965YP	2	WASHER, 1.25 X .765 X .03, Thrust, ZC/CL
0140-110	7031970YP	2	PLATE, Differential Gear, V21
0140-120	7050767YP	1	ASSEMBLY, Input Gear
0140-130	7051903AYP	1	WELDMENT, Differential Bracket
0140-140	703934	1	SPACER, .820 OD X .720 ID X .330 L
0140-20	7050830YP	1	ASSEMBLY, Short Axle
0140-30	7050831YP	1	ASSEMBLY, Long Axle
0150	7053939YP	1	ASSEMBLY, Left Housing
0150-10	7012314YP	2	SEAL, 5/8" ID
0150-20	7029033YP	1	HOUSING, Left Hand
0150-30	7029035YP	2	BEARING, Tapered, Differential Housing
0160	7051908YP	1	ASSEMBLY, Housing, Right Hand
0160-30	703935	3	BOLT, 5/16-24 x 1-1/8" Rib Neck, GR 5, ZC/BK
0160-40	7024442YP	3	GASKET, 5/8" O.D.
0160-50	7029034YP	1	HOUSING, Right Hand
0160-70	7073963YP	1	BEARING, Ball, 1.125 OD, .440 ID, 3.8 Wide
0170	703936	3	WASHER, .325 ID X .850 OD X .041 Thk, Internal External Lock, Type A, ZC/CL
0180	703937	4	NUT, #10-32, Nyloc, GR A, ZC/CL
0190	703938	4	SCREW, #10-32 x 1-1/2 Hex Head Cap GR5, ZC/CL
0210	703349	1	WASHER, .453 X .75 X .073, Flat, ZC/CL
0220	703459	4	NUT, 5/16-24, Hex Crown Lock, GR C, Zinc/Clear
0230	703939	1	WASHER, .32 ID x 1.40 OD x .10 Thk, Bellville, ZC/CL
0240	703833	4	SCREW, 1/4-20 x 1 Hex Washer Self-Tap, ZC/CL
0250	7034179BMYP	1	LINK, Differential, Commercial
0260	703940	1	WASHER, 0.445 ID X 0.780 OD X 0.025 Thk, Wave, ZC/CL

**Footnotes:**





---

<b>Item</b>	<b>Part No</b>	<b>Qty</b>	<b>Description</b>
0010	7075471YP	1	DECAL, Speed Shift
0050	7104148YP	1	DECAL, Logo, Snapper, 7.88"
0070	7029782MA	1	DECAL, OPC Bail International Symbol
0110	7102996YP	1	DECAL, ICES, Canadian Spark Compliance
0600-10	7105261YP	1	DECAL, CPSC, French/English
0600-20	7106303YP	1	DECAL, Warning/Danger, English/French
0600-30	7106304YP	1	DECAL, Danger, English/French
0600-40	7106305YP	1	DECAL, Spark Arrestor, English/French
0610	7106320YP	1	DECAL, Turtle, 8.50TP
0620	7106324YP	1	DECAL, Commercial Ninja

Not for  
Reproduction

**Footnotes:**

# Grass Catcher (7060936)

Note: Unless noted otherwise, use the standard torque specifications

Mfg. No: 7060936YP

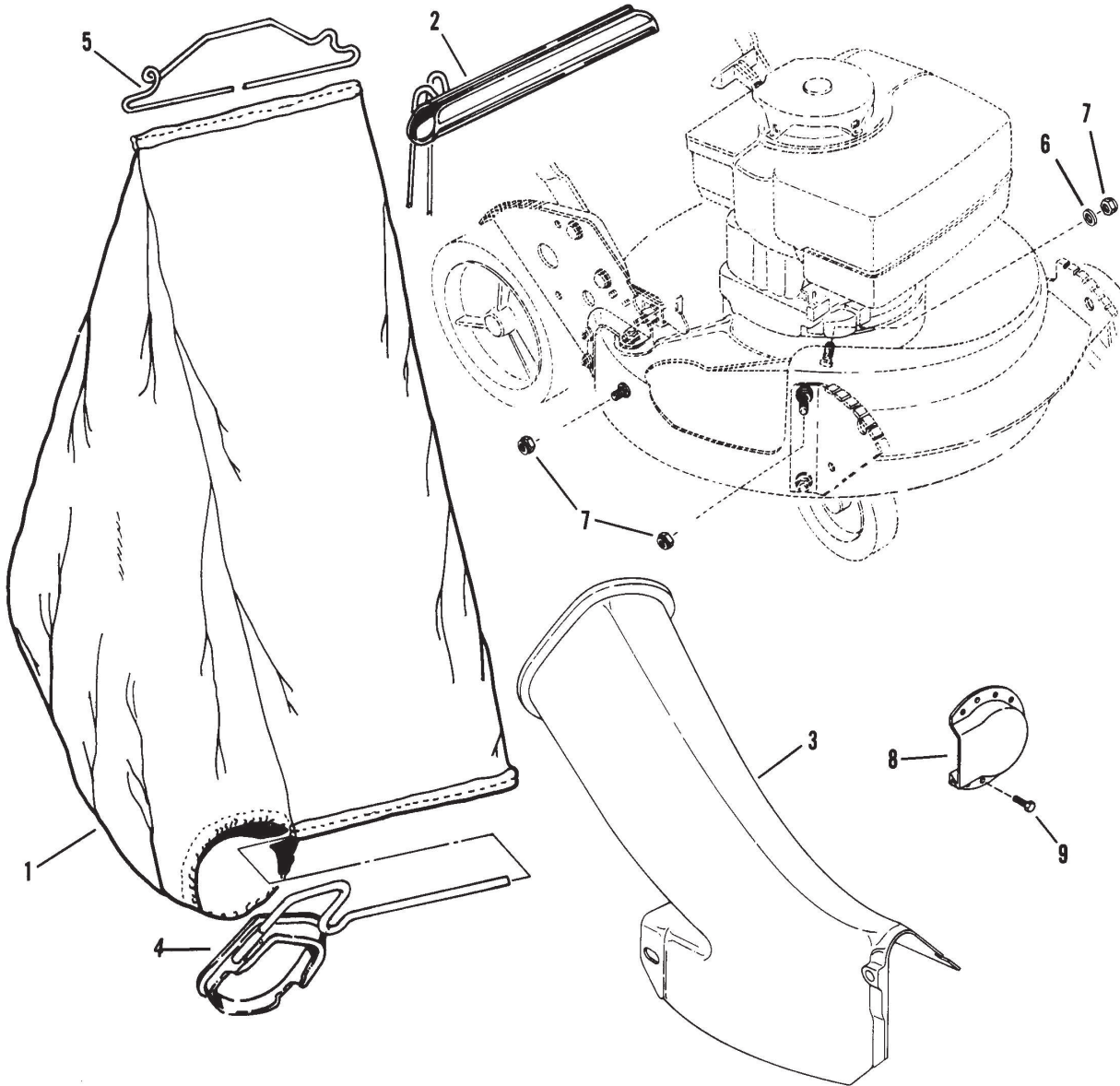

## Grass Catcher (7060936)

REF NO	PART NO	QTY	DESCRIPTION
--	7060936	1	KIT, Grass Bag Catcher -(Includes items 1 & 2)
1	7074426	1	BAG, Grass Slider (Black/Gold) (10.75" Wide) -Was 23774
2	7050711	1	ASSEMBLY, Slider
3	7016050	1	ADAPTER, GRASS BAG DECK
4	7042489	1	CONNECTOR, Grass Bag -Was 47969
5	7019247	1	WIRE, Bag Connector (12" Wide)
6	7090188	1	WASHER, 3/8" Flat
7	7090951	3	NUT, 5/16-18 Hex Large Flange Center Lock
8	7076355	1	DEFLECTOR, Muffler (Briggs) -Was 23031
9	7023023	3	SCREW, #8-18 x 3/8" Hex Head (Tapered)
--	7016268	1	BAG, Polyethylene -(Not Shown)

Not for  
Reproduction

# Hardware Identification & Torque Specifications

Torque Specification Chart								
FOR STANDARD METRIC MACHINE HARDWARE (Tolerance ± 20%)								
Property Class	5.6		8.8		10.9		12.9	
	Class 5.6		Class 8.8		Class 10.9		Class 12.9	
Size Of Hardware	in/lbs		in/lbs		in/lbs		in/lbs	
	ft/lbs	Nm.	ft/lbs	Nm.	ft/lbs	Nm.	ft/lbs	Nm.
M3	5.88	.56	13.44	1.28	19.2	1.80	22.92	2.15
M4	13.44	1.28	30.72	2.90	43.44	4.10	52.56	4.95
M5	26.4	2.50	60.96	5.75	5.97	8.10	7.15	9.7
M6	44.64	4.3	7.3	9.9	10.3	14	12.1	16.5
M7	5.2	7.1	12.1	16.5	16.9	23	19.9	27
M8	7.7	10.5	17.7	24	25	34	29	40
M10	15	21	35	48	50	67	59	81
M12	26	36	61	83	86.2	117	103	140
M14	42	58	101	132	136	185	162	220
M16	64	88	147	200	210	285	250	340
M18	89	121	202	275	287	390	346	470
M20	126	171	290	390	405	550	486	660
M22	169	230	390	530	559	745	656	890
M24	217	295	497	375	708	960	840	1140
M27	320	435	733	995	1032	1400	1239	1680
M30	435	590	995	1350	1401	1900	1681	2280
M33	590	800	1349	1830	1902	2580	2278	3090
M36	759	1030	1740	2360	2441	3310	2935	3980
M39	988	1340	2249	3050	3163	4290	3798	5150

Torque Specification Chart						
FOR STANDARD MACHINE HARDWARE (Tolerance ± 20%)						
Hardware Grade	No Marks		SAE Grade 5		SAE Grade 8	
	SAE Grade 2		SAE Grade 5		SAE Grade 8	
Size Of Hardware	in/lbs		in/lbs		in/lbs	
	ft/lbs	Nm.	ft/lbs	Nm.	ft/lbs	Nm.
8-32	19	2.1	30	3.4	41	4.6
8-36	20	2.3	31	3.5	43	4.9
10-24	27	3.1	43	4.9	60	6.8
10-32	31	3.5	49	5.5	68	7.7
1/4-20	66	7.6	8	10.9	12	16.3
1/4-28	76	8.6	10	13.6	14	19.0
5/16-18	11	15.0	17	23.1	25	34.0
5/16-24	12	16.3	19	25.8	29	34.0
3/8-16	20	27.2	30	40.8	45	61.2
3/8-24	23	31.3	35	47.6	50	68.0
7/16-14	30	40.8	50	68.0	70	95.2
7/16-20	35	47.6	55	74.8	80	108.8
1/2-13	50	68.0	75	102.0	110	149.6
1/2-20	55	74.8	90	122.4	120	163.2
9/16-12	65	88.4	110	149.6	150	204.0
9/16-18	75	102.0	120	163.2	170	231.2
5/8-11	90	122.4	150	204.0	220	299.2
5/8-18	100	136	180	244.8	240	326.4
3/4-10	160	217.6	260	353.6	386	525.0
3/4-16	180	244.8	300	408.0	420	571.2
7/8-9	140	190.4	400	544.0	600	816.0
7/8-14	155	210.8	440	598.4	660	897.6
1-8	220	299.2	580	788.8	900	1,244.0
1-12	240	326.4	640	870.4	1,000	1,360.0

The guides and ruler furnished below are designed to help you select the appropriate hardware.

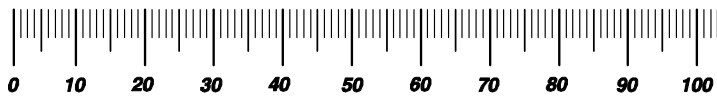

Nut, M8

Thread Diameter (mm)  
Inside Diameter (in)    Threads per inch

Nut, 1/2-16

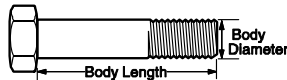

Screw, M8- 1.25 x 25

Thread Diameter (mm)    Distance between threads (mm)    Body Length (mm)  
Body Diameter    Threads per inch    Body Length (in)

Screw, 1/2- 16 x 2

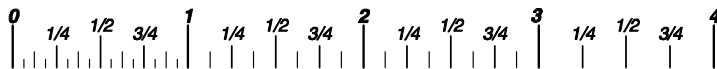

## Standard Hardware Sizing

When a washer or nut is identified as 1/2" (M8), this is the *Nominal size*, meaning the *inside diameter* is 1/2 inch (8mm metric thread diameter); if a second number is present it represents the *threads per inch* (distance between threads).

When bolt or capscrew is identified as 1/2 - 16 x 2" (M8 - 1.25 x 50), this means the *Nominal size*, or body diameter is 1/2 inch (8mm metric thread diameter), the second number, 16, represents the *threads per inch*, (1.25 thread diameter). The final number is the body length of the bolt or screw, 2 inches (50mm).

## NOTES

- These torque values are to be used for all hardware excluding: locknuts, self-tapping screws, thread forming screws, sheet metal screws and socket head setscrews.
- Recommended seating torque values for locknuts:
  - for prevailing torque locknuts - use 65% of grade5 torques.
  - for flange whizlock nuts and screws - use 135% of grade 5 torques.
- Unless otherwise noted on assembly drawings, all torque values must meet this specification.

## Common Hardware Types

Hex Head Capscrew



Washer

Lockwasher

Carriage Bolt



Hex Nut

## Wrench & Fastener Size Guide

1/4" Bolt or Nut Wrench—7/16"	5/16" Bolt or Nut Wrench—1/2"	3/8" Bolt or Nut Wrench—9/16"	7/16" Bolt or Nut Wrench (Bolt)—5/8" Wrench (Nut)—11/16"	1/2" Bolt or Nut Wrench—3/4"
M6 Bolt or Nut Wrench—10mm	M8 Bolt or Nut Wrench—13mm	M10 Bolt or Nut Wrench—17mm	M12 Bolt or Nut Wrench—19mm	M14 Bolt or Nut Wrench—22mm

*Parts Manual for*

# **SNAPPER®**

## **21" STEEL DECK WALK BEHIND COMMERCIAL MOWER SERIES 20**

Not for  
Reproduction

IT IS THE POLICY OF BRIGGS & STRATTON CORP TO IMPROVE ITS PRODUCTS WHENEVER IT IS POSSIBLE AND PRACTICAL TO DO SO. WE RESERVE THE RIGHT TO MAKE CHANGES OR ADD IMPROVEMENTS AT ANY TIME WITHOUT INCURRING ANY OBLIGATION TO MAKE SUCH CHANGES ON PRODUCTS

**Briggs & Stratton Yard Power Products Group**

535 Macon Road  
McDonough, GA, 30253 U.S.A.  
800-935-2967

[www.snapper.com](http://www.snapper.com)

Copyright © 2015 Briggs & Stratton Corporation  
Milwaukee, WI USA. All Rights Reserved

**Manual No. 1759770  
Revision: A 7/28/2015**