

## **Broadmoor**

### **Series Lawn Tractors & Mower Decks**

#### **20HP Products**

**Mfg. No. Description**

2690948 Broadmoor, 20HP Hydro RMO and 46" Mower Deck

2690949 Broadmoor, 20HP Hydro RMO and 52" Mower Deck

#### **21HP Products**

**Mfg. No. Description**

2691111-00 Broadmoor, 21HP Hydro RMO and 44" Mower Deck

2691112-00 Broadmoor, 21HP Hydro RMO and 50" Mower Deck

#### **22HP Products**

**Mfg. No. Description**

2690947 Broadmoor, 22HP Hydro RMO and 44" Mower Deck

2690947-01 Broadmoor, 22HP Hydro RMO and 44" Mower Deck

#### **Mower Decks**

**Mfg. No. Description**

1695727 44" Mower Deck

1695551 46" Mower Deck

1695768 52" Mower Deck



<b>PRODUCT COMPONENTS</b>	<b>PAGES</b>
Frame & Front Axle Group .....	4
Steering Group - Manual Steering .....	6
Engine Group - 20HP, 21HP, 22HP, 24HP & 27HP, Twin .....	8
Transmission Group - Tuff Torq K57 .....	12
Transmission SERVICE PARTS - Tuff Torq K57A .....	14
Control Group - Cruise Control .....	18
Controls Group .....	20
Electrical Group .....	22
Hood, Grille & Dash Group .....	26
Seat & Seat Deck Group - EVAP Compliant .....	28
Lift Group - Manual .....	30
Lift Group - Manual with Cruise Control .....	32
Wheels & Tires Group .....	34
Decals - Brand & Model .....	36
Decals - Safety & Common .....	38
44" Mower Deck - Clutch & Support Group .....	40
44" Mower Deck - Electric Height Adjustment & Roller Bar Group .....	42
44" Mower Deck - Housing, Arbors & Blades Group .....	46
46" & 52" Mower Deck - Clutch & Support Group .....	50
46" & 52" Mower Deck - Height Adjustment & Roller Bar Group .....	52
46" & 52" Mower Deck - Housing, Arbors & Blades Group .....	56
50" Mower Deck - Clutch & Support Group .....	58
50" Mower Deck - Electric Height Adjustment & Roller Group .....	60
50" Mower Deck - Housing, Arbors & Blades Group .....	64
<b>Torque Specification Chart .....</b>	<b>Inside Back Cover</b>

# Frame & Front Axle Group

986681

**NOTE:** Unless noted otherwise, use the standard hardware torque specification chart.

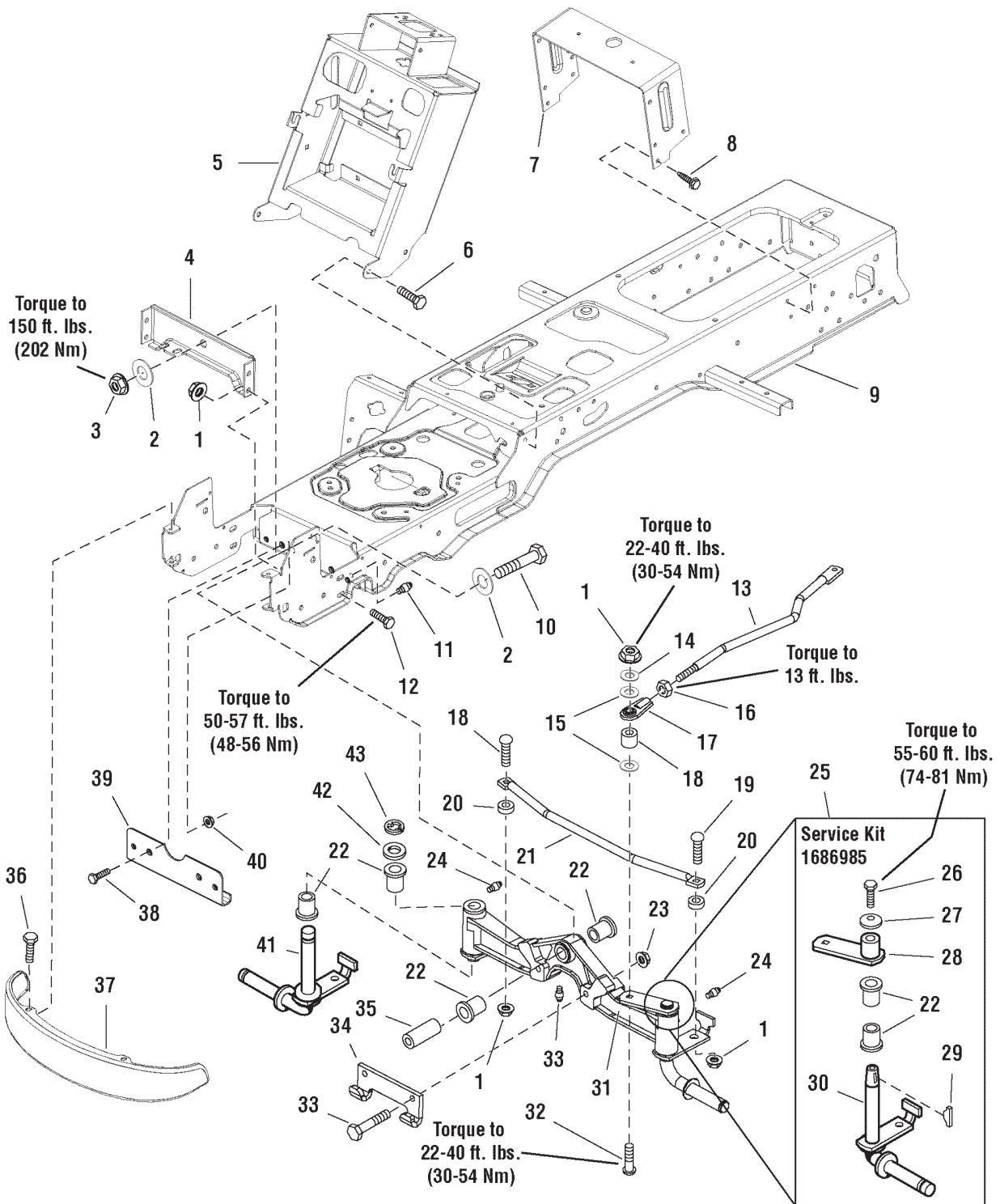

**The above parts group applies to the following Mfg. Nos.:**

- 2690947 - Broadmoor
- 2690947-01 - Broadmoor
- 2690948 - Broadmoor
- 2690949 - Broadmoor
- 2691111-00 - Broadmoor
- 2691112-00 - Broadmoor

## Frame & Front Axle Group

REF NO	PART NO.	QTY.	DESCRIPTION
1	1930645	7	NUT, Hex Flange Lock, 3/8-16
2	1960035	2	WASHER
3	2860646	1	NUT, Hex Flange, 5/8-11
4	1722212A	1	PLATE, Axle
5	1733765A	1	TOWER & SUPPORT ASSEMBLY
6	1923683	4	CAPSCREW, Hex Head Taptite, 3/8-16 x 3/4
7	1723528A	1	SUPPORT
8	1664847SM	4	CAPSCREW, Hex Head Taptite, 5/16-18 x 3/4
9	1726989A	1	FRAME ASSEMBLY
10	2860645	1	CAPSCREW, 5/8-11 x 3-1/2
11	1704314	2	FITTING, Grease for Wear Plate, 1/4-20, with Ball
12	1933260	4	CAPSCREW, Hex Head, Flange Lock, 3/8-16 x 3/4
13	1722541	1	LINK, Drag
14	1922755	1	WASHER
15	1960103	2	WASHER
16	1919262	1	NUT, Hex Jam, 1/2-20
17	1702779	1	JOINT, Ball
18	1708236	1	SPACER
19	1931350	2	CARRIAGE BOLT, 3/8-16 x 1
20	1611705	2	SPACER
21	1722626A	1	ROD, Tie
22	1721682	6	BUSHING
23	1930650	2	NUT, Hex Flange Lock, 7/16-14
24	2821133	3	FITTING, Lube
25	1686985	1	SPINDLE REPLACEMENT KIT, LH (Includes Ref. Nos. 22, 26, 27, 28, 29 & 30)
26	2823485	1	CAPSCREW, 3/8-16 x 7/8, GR8
27	1663151	1	WASHER, Spring, 3/8
28	1725112	1	HUB & ARM ASSEMBLY
29	2830671	1	KEY, Woodruff
30	1724264	1	SPINDLE, LH
31	1722200A	1	AXLE ASSEMBLY, w/ LH Spindle, Complete (Includes Ref. Nos. 22, 24, 41, 42 & 43)
32	1931352	1	CARRIAGE BOLT, 3/8-16 x 1-1/2
33	1927531	2	CAPSCREW, Hex Head, 7/16-14 x 2, GR8
34	1721918A	1	HOOK, "J"
35	1721752	1	SPACER
36	1960086	4	SCREW, Torx Head, 5/16-18 x 7/8
37	1721805A	1	BUMPER, Black, Steel, Standard
37	1723502	1	BUMPER, Chrome, Optional
38	1930591	2	CAPSCREW, Hex Whiz Lock, 5/16-18 x 3/4
39	1724801A	1	PLATE, Axle Wear
40	1931277	2	NUT, Hex Falnge Whiz Lock, 5/16-18
41	1722199	1	SPINDLE, RH
42	1919394	1	WASHER
43	2832577	1	RETAINING RING

### Footnotes

#### The above parts group applies to the following Mfg. Nos.:

2690947 - Broadmoor  
 2690947-01 - Broadmoor  
 2690948 - Broadmoor  
 2690949 - Broadmoor  
 2691111-00 - Broadmoor

# Steering Group - Manual Steering

NOTE: Unless noted otherwise, use the standard hardware torque specification chart.

0758985890

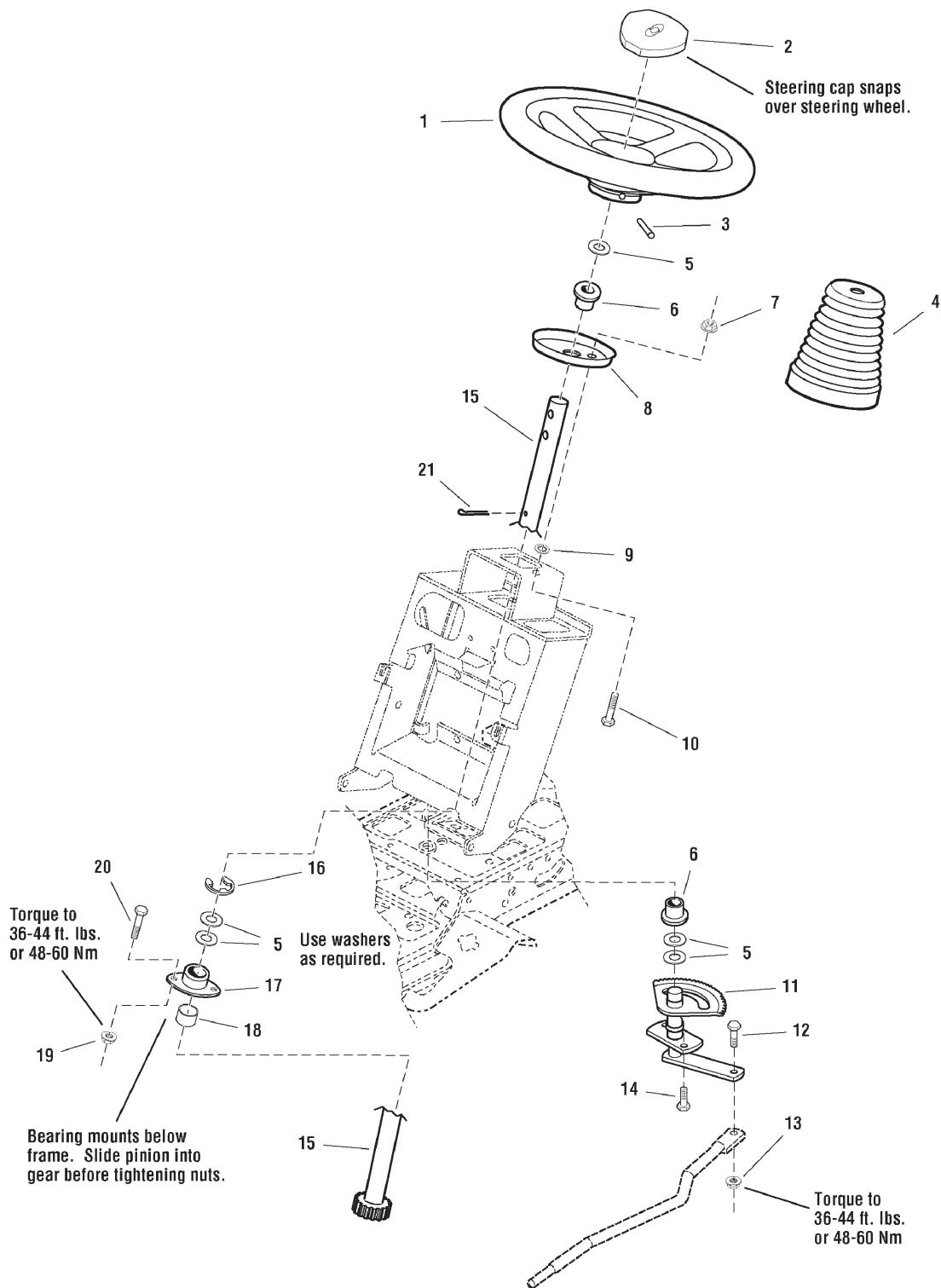

**The above parts group applies to the following Mfg. Nos.:**

- 2690947 - Broadmoor
- 2690947-01 - Broadmoor
- 2690948 - Broadmoor
- 2690949 - Broadmoor
- 2691111-00 - Broadmoor
- 2691112-00 - Broadmoor

## Steering Group - Manual Steering

REF NO	PART NO.	QTY.	DESCRIPTION
1	1722318	1	STEERING WHEEL, Straight, Shaft
2	1722319	1	CAP, Steering Wheel, Simplicity (Decal Not Included)
2	1725024	1	CAP, Steering Wheel, Plain
3	1960540	1	PIN, Spring, 5/16 x 2-1/2
4	1722749	1	COVER, Rubber, Upper Steering Shaft
5	1960114	5	WASHER, 3/4
6	2176440	2	BUSHING, 15/32 x 7/8 x 7/8, Nylon
7	1960636	2	NUT, Hex KEPS 5/6-18
8	1721736A	1	PLATE, Mounting Steering
9	1933988	2	NUT, Push
10	1960655	2	CARRIAGE BOLT, 5/16-18 x 1-1/4
11	1724470A	1	GEAR & SHAFT ASSEMBLY, Steering
12	1960032	1	CAPSCREW, Hex Head, 3/8-16 x 1-1/4, Black
13	1930645	1	NUT, Hex Flange Two-Way Lock, 3/8-16
14	1664847SM	2	CAPSCREW, Hex Washer Head Taptite, 5/16-18 x 3/4
15	1721626	1	SHAFT & PINION ASSEMBLY, Steering Manual
16	1611710	1	RING, Clipring Extension
17	1722459	1	BEARING, 3/4 x 1-11/16 x 13/16, 3" Long Housing
18	1722461	1	SPACER, 3/4 x 1-1/16 x 3/8, Powder Metal
19	1931211	2	NUT, Hex Flange Whiz Lock, 3/8-16, Small
20	1933260	2	CAPSCREW, Hex Whiz Lock Flange, 3/8-16 x 3/4, Black
21	1960033	1	CLIP, Hairpin

## Footnotes

---

### The above parts group applies to the following Mfg. Nos.:

2690947 - Broadmoor

2691112-00 - Broadmoor

2690947-01 - Broadmoor

2690948 - Broadmoor

2690949 - Broadmoor

2691111-00 - Broadmoor

# Engine Group - 20HP, 21HP, 22HP, 24HP & 27HP, Twin

**NOTE:** Unless noted otherwise, use the standard hardware torque specification chart.

989518-27HP\_9899520-24HP\_989522-20HP\_989523-22HP

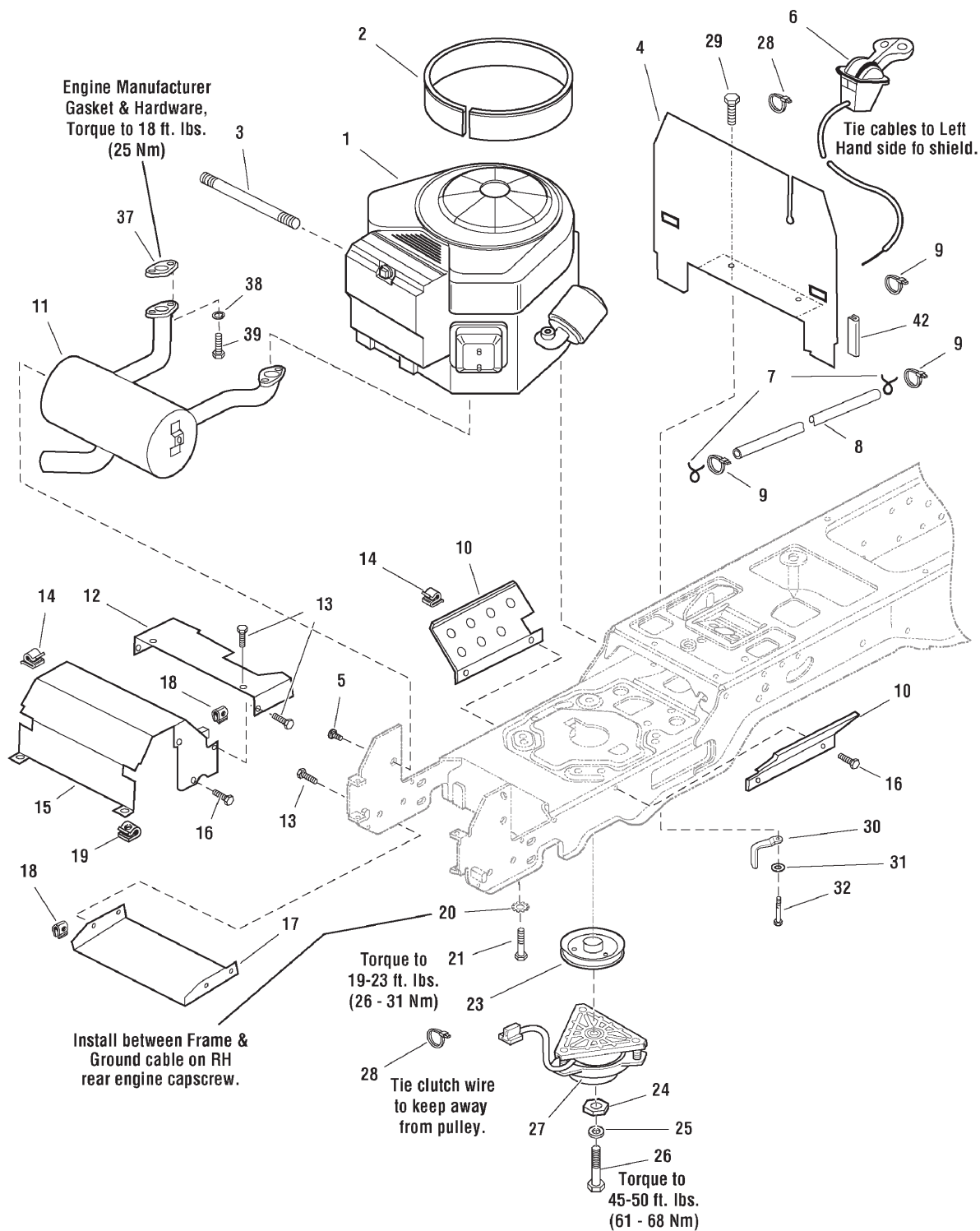

**The above parts group applies to the following Mfg. Nos.:**

- 2690947 - Broadmoor
- 2690947-01 - Broadmoor
- 2690948 - Broadmoor
- 2690949 - Broadmoor
- 2691111-00 - Broadmoor
- 2691112-00 - Broadmoor



## Engine Group - 20HP, 21HP, 22HP, 24HP & 27HP, Twin

REF NO	PART NO.	QTY.	DESCRIPTION
1	358777-1124-G1	1	* ENGINE, 20 HP Briggs & Stratton Vanguard Twin (Engine Model: 358777-1124-G1)
1	385777-1113-G1	1	* ENGINE, 21 HP Briggs & Stratton Vanguard Twin (Engine Model: 385777-1113-G1)
1	40H777-2165-G	1	* ENGINE, 24 HP Briggs & Stratton Profesional Series (Engine Model: 40H777-2165-G5)
1	PS-CV740-3129	1	** ENGINE, 27 HP Kohler Twin (Engine Model: PS-CV740-3129)
1	40H777-5136-G	1	* ENGINE, 22 HP Briggs & Stratton Profesional Series (Engine Model: 40H777-5136-G5)
2	1734166	1	EDGING, Airduct (20HP & 27HP Models Only)
3	1723165	1	HOSE, Oil Drain
4	1722388A	1	HEAT SHIELD
5	1924856	2	CAPSCREW, Hex Head, Taptite, 5/16-18 x 1/2
6	1737747	1	THROTTLE CONTROL (22HP & 24HP Models Only)
6	1734506	1	THROTTLE CONTROL (20HP, 21HP & 27HP Models Only)
7	791850	2	CLAMP, Hose, Wire
8	1734985	1	HOSE, Fuel, 59" Long (22HP, 24HP & 27HP Models Only)
8	5050831X53	1	HOSE, Fuel, 53" Long (20HP & 21HP Models Only)
9	1701011	1	TIE, Self Locking, 7-5/16 Long
10	1722392A	2	SHIELD, Side, Heat
11	1721705	1	MUFFLER ASSEMBLY (22HP, 24HP & 27HP Models Only)
11	1736543	1	MUFFLER ASSEMBLY (21HP Models Only)
11	1722625	1	MUFFLER ASSEMBLY (20HP Models Only)
12	1722390A	1	DUCT, Muffler Extension
13	1960295	8	CAPSCREW, Hex, Whiz Lock, 1/4-20 x 5/8
14	2834683	2	CLIP, Wire
15	1722389A	1	DUCT, Muffler Top
16	1927428	8	CAPSCREW, Hex Head Taptite, 1/4-20 x 3/8
17	1722414A	1	SHIELD, Muffler Bottom
18	1960368	8	NUT, Speed, 1/4-20
19	1935255	2	NUT, Speed, 3/8-18
20	2820427	1	WASHER, Locking, External Teeth, 3/8
21	704010	1	CAPSCREW, Hex Head, Taptite, 3/8-16 x 1-1/2
23	1739847	1	PULLEY, Engine (22HP Models Only)
23	1732576	1	PULLEY, Engine (20HP, 24HP & 27HP Models Only)
24	1708264	1	WASHER, Hex, 7/16 x 1-1/2
25	1918199	1	WASHER, Locking, 7/16
26	1960649	1	CAPSCREW, Hex Head 7/16-20 x 3-1/2 (20HP & 27HP Models Only)
27	1736105	1	CLUTCH (20HP, 24HP & 27HP Models Only)
27	1717664	1	CLUTCH (22HP Models Only)
28	2832747	2	TIE, Self Locking
29	1925003	2	CAPSCREW, Hex Head Taptite, 1/4-20 x 1/2
30	1737421A	1	GUIDE, Belt Retainer, Clutch (20HP, 24HP & 27HP Models Only)
30	1737420A	1	GUIDE, Belt Retainer, Clutch (22HP Models Only)
31	1924940	2	WASHER, Flat, 3/8
32	2827187	1	CAPSCREW, Hex Head 3/8-16 x 1 (20HP Models Only)
37	-----	2	* GASKET
38	1917356	4	LOCKWASHER, 5/16

### Footnotes

Note\* To verify your specific engine model, please reference the ID Tag located on your engine. See your local Briggs & Stratton distributor for parts and service.

### The above parts group applies to the following Mfg. Nos.:

2690947 - Broadmoor  
 2690947-01 - Broadmoor  
 2690948 - Broadmoor  
 2690949 - Broadmoor  
 2691111-00 - Broadmoor

# Engine Group - 20HP, 21HP, 22HP, 24HP & 27HP, Twin

NOTE: Unless noted otherwise,  
use the standard hardware torque  
specification chart.

989518-27HP\_9899520-24HP\_989522-20HP\_989523-22HP

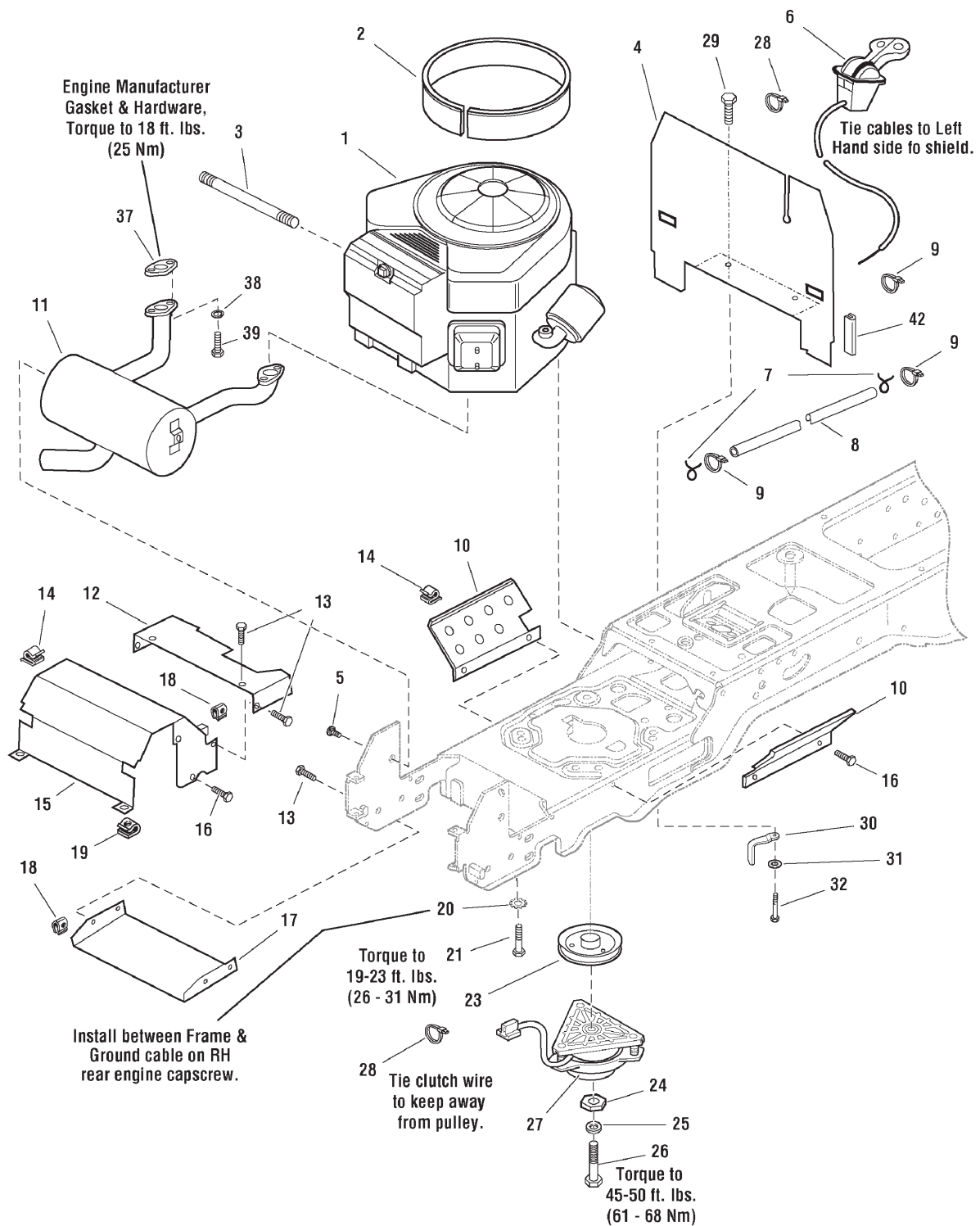

## The above parts group applies to the following Mfg. Nos.:

- 2690947 - Broadmoor
- 2690947-01 - Broadmoor
- 2690948 - Broadmoor
- 2690949 - Broadmoor
- 2691111-00 - Broadmoor
- 2691112-00 - Broadmoor

## **Engine Group - 20HP, 21HP, 22HP, 24HP & 27HP, Twin**

---

<b>REF NO</b>	<b>PART NO.</b>	<b>QTY.</b>	<b>DESCRIPTION</b>
39	2860660	4	CAPSCREW, Socket Head, 5/16-18 x 7/8, G8
42	1723894	1	EDGING, Rubber

---

### **Footnotes**

Note\* To verify your specific engine model, please reference the ID Tag located on your engine. See your local Briggs & Stratton distributor for parts and service.

---

### **The above parts group applies to the following Mfg. Nos.:**

2690947 - Broadmoor  
2690947-01 - Broadmoor  
2690948 - Broadmoor  
2690949 - Broadmoor  
2691111-00 - Broadmoor  
2691112-00 - Broadmoor

# Transmission Group - Tuff Torq K57

986603

**NOTE:** Unless noted otherwise, use the standard hardware torque specification chart.

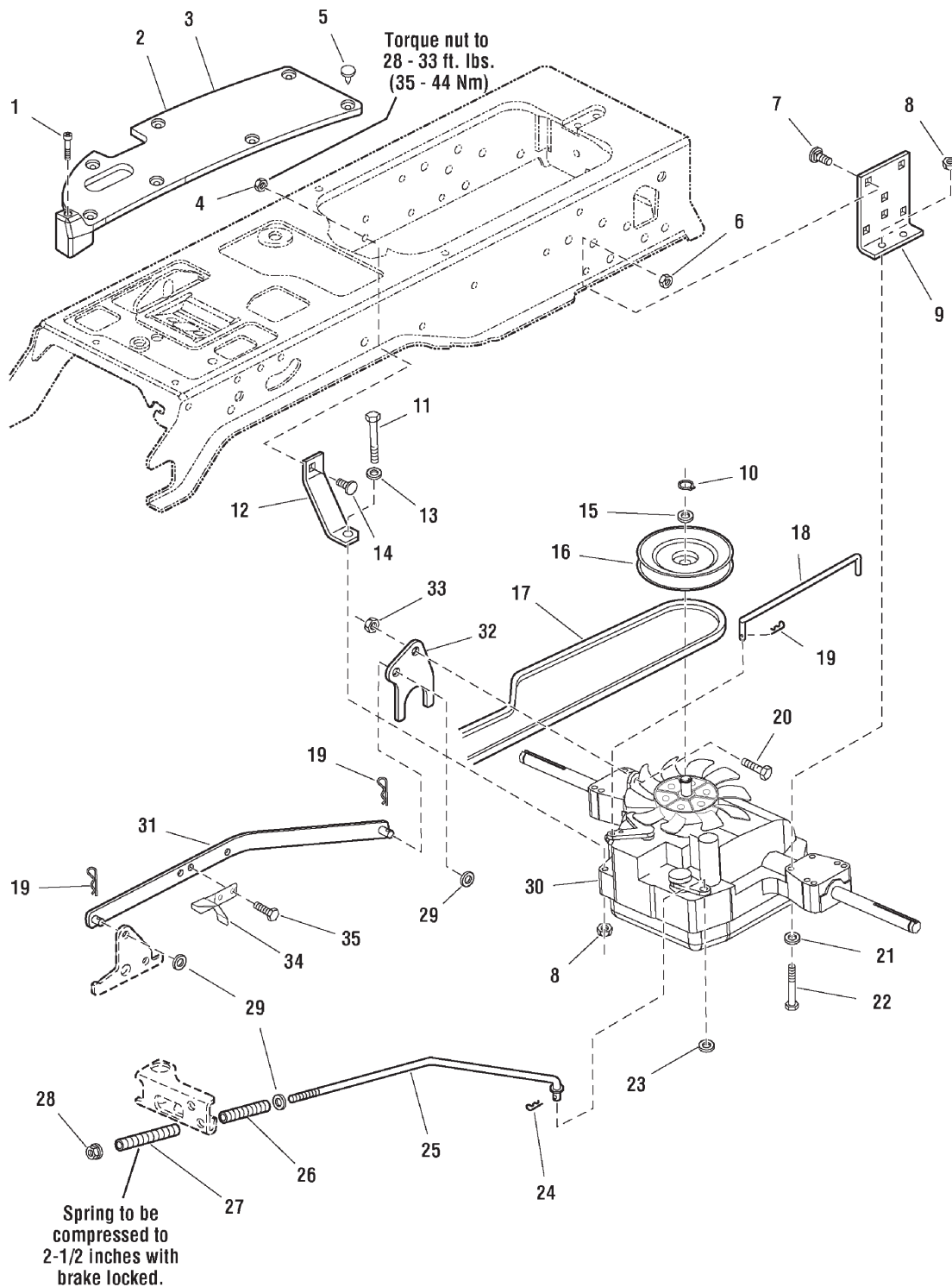

**The above parts group applies to the following Mfg. Nos.:**

- 2690947 - Broadmoor
- 2690947-01 - Broadmoor
- 2690948 - Broadmoor
- 2690949 - Broadmoor
- 2691111-00 - Broadmoor
- 2691112-00 - Broadmoor

## Transmission Group - Tuff Torq K57

REF NO	PART NO.	QTY.	DESCRIPTION
1	1960676	2	SCREW, Pan Head Torx Taptite, 1/4-20 x 1-1/4, Black
2	1722345	1	PAD, Footrest, LH, without Differential Lock
3	1722173	1	PAD, Footrest, RH
4	1960636	1	NUT, Hex KEPS, 5/16-18, Black
5	1704351	15	FASTENER, Panel
6	1960637	6	NUT, Hex KEPS, 3/8-16, Black
7	1931350	6	CARRIAGE BOLT, 3/8-16 x 1, Black
8	1960686	5	NUT, Hex Flange ESNA, 5/16-18, Black
9	1721728A	2	SUPPORT, Transmission
10	1724316	1	RING, Snap, Transmission
11	1921978	1	CAPSCREW, Hex Head 5/16-18 x 2 G5
12	1721592A	1	STRAP, Torque
13	1960141	1	WASHER, 5/16, Black
14	1931335	1	CARRIAGE BOLT, 5/16-18 x 1, Black
15	1960027	2	WASHER, 1/2
16	1721666	1	PULLEY & HUB ASSEMBLY
17	1726841	1	V-BELT, Drive
18	1726806	1	ROD, Transmission Release
19	1722460	3	PIN, Quick
20	1921332	1	CAPSCREW, Hex Head, 5/16-18 x 2
21	1919326	4	WASHER, 5/16, Black
22	1923141	4	CAPSCREW, Hex Head, 5/16-18 x 2-3/4, Black
23	1918267	1	WASHER, 15/32 x 15/16, Black
24	1918447	1	PIN, Cotter, Black
25	1726871	1	ROD, Brake
26	1722684	1	SPRING, Compression, 3-1/4" Long, Black
27	1729277	1	SPRING, Compression, 3-5/8" Long, Black
28	1960687	1	NUT, Hex Flange ESNA, 3/8-16, Black
29	1924940	3	WASHER, 3/8, Black
30	1722668	1	TRANSMISSION ASSEMBLY, K57, without Pulley
31	1732190A	1	CONTROL ARM ASSEMBLY
32	1724423A	1	ARM, Control
33	1960636	2	NUT, KEPS Lock, 5/16-18
34	1727215A	1	ACTUATOR, Switch
35	1924856	2	CAPSCREW, Hex Head Taptite, 5/16-18 x 1/2

### Footnotes

#### The above parts group applies to the following Mfg. Nos.:

2690947 - Broadmoor  
 2690947-01 - Broadmoor  
 2690948 - Broadmoor  
 2690949 - Broadmoor  
 2691111-00 - Broadmoor

# Transmission SERVICE PARTS - Tuff Torq K57A

06061722668

NOTE: Unless noted otherwise,  
use the standard hardware torque  
specification chart.

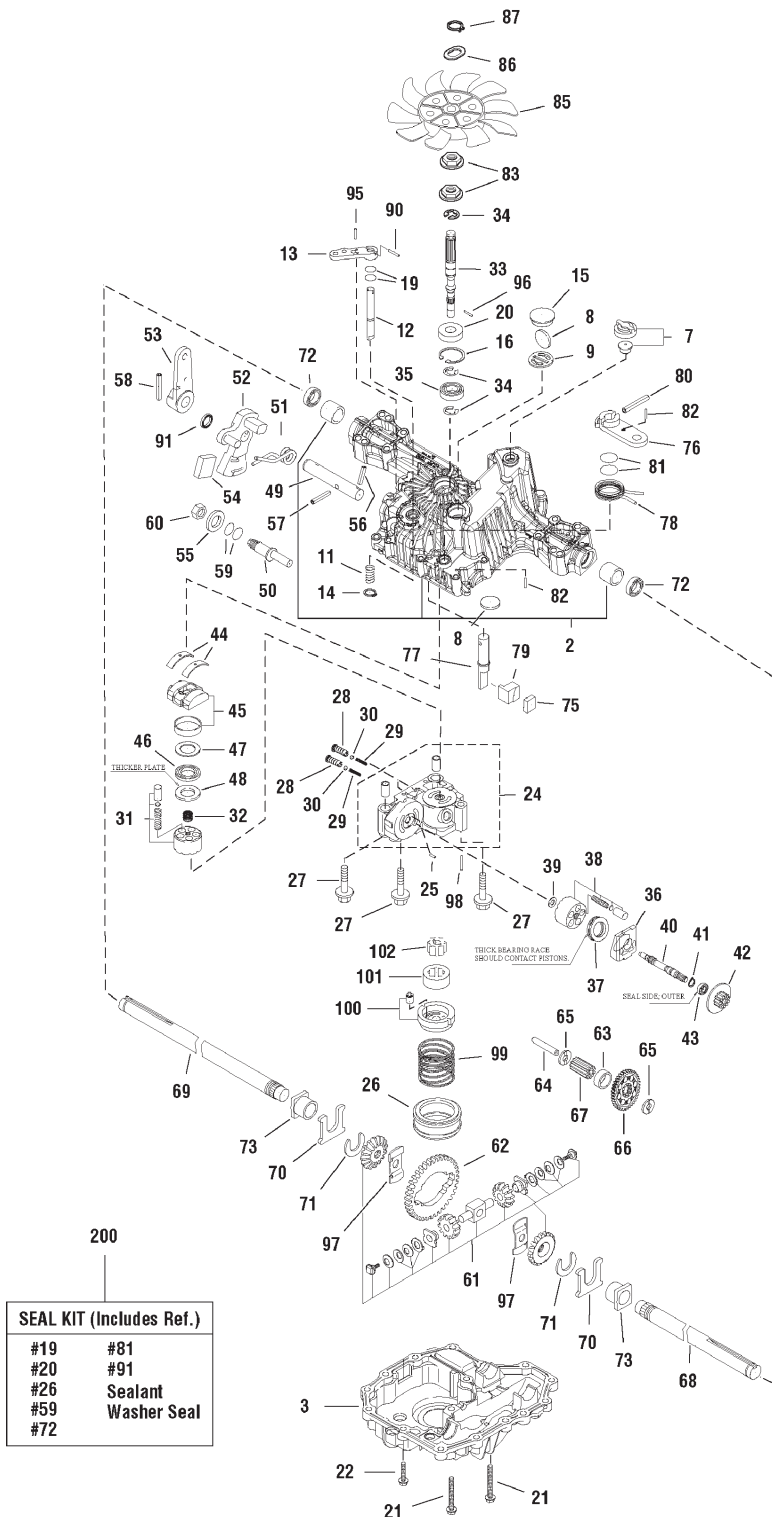

The above parts group applies to the following Mfg. Nos.:

- 2690947 - Broadmoor
- 2690947-01 - Broadmoor
- 2690948 - Broadmoor
- 2690949 - Broadmoor
- 2691111-00 - Broadmoor
- 2691112-00 - Broadmoor

## Transmission SERVICE PARTS - Tuff Torq K57A

REF NO	PART NO.	QTY.	DESCRIPTION
2	----	1	*HOUSING ASSEMBLY, Upper
3	1724938	1	HOUSING, LOWER
7	1718052	1	VENT VALVE 15
8	1724279	2	MAGNET, K50
9	----	1	*HOLDER, Magnet
11	1725730	1	SPRING
12	1724281	1	SHAFT, Bypass
13	1720418	1	LEVER, Bypass
14	1718061	1	RING
15	1724282	1	SEALING CAP
16	1708650	1	RING 35
19	1708691	2	PACKING
20	1708651	1	SEAL TC
21	1707789	14	SCREW, Tapping
22	----	2	*SCREW, Tapping
24	1724939	1	CASE, CENTER
25	1718070	1	PIN 3 x 9.8
26	1724954	1	FILTER
27	1720805	3	BOLT 10 x 75
28	1724286	2	VALVE, IDS 1.0
29	1724287	2	SPRING, IDS
30	----	2	*BALL, 3/16
31	----	1	*CYLINDER BLOCK ASSEMBLY
32	1724290	1	SPRING, PUMP
33	1724941	1	SHAFT, PUMP
34	1718076	3	RING E15
35	1708673	1	BEARING
36	1718077	1	HOUSING
37	----	1	*BEARING, Thrust
38	1718079	1	BLOCK, CYLINDER
39	1718084	1	WASHER 12 x 24 x 1
40	1724943	1	SHAFT, MOTOR
41	1708672	1	RING 15
42	1724944	1	GEAR, MOTOR
43	1718083	1	BEARING 6202UC3
44	1718089	2	THRUST METAL
45	1720426	1	SWASH PLATE ASSEMBLY
46	1718088	1	THRUST PLATE B
47	1718086	1	BEARING K81105
48	1718087	1	THRUST PLATE A
49	----	1	*SHAFT, Control
50	----	1	*FULCRUM, ECCENTRIC
51	1724345	1	SPRING, Torsion
52	1724346	1	LEVER, Control
53	1724347	1	ARM, Control

### Footnotes

\*Note: See your local authorized dealership for parts and warranty or contact Tuff Torq at [www.tufftorqservices.com](http://www.tufftorqservices.com) (U.S. 1-866-572-3441 Int'l 01-423-585-1977)

### The above parts group applies to the following Mfg. Nos.:

2690947 - Broadmoor  
 2690947-01 - Broadmoor  
 2690948 - Broadmoor  
 2690949 - Broadmoor  
 2691111-00 - Broadmoor

# Transmission SERVICE PARTS - Tuff Torq K57A

06061722668

NOTE: Unless noted otherwise,  
use the standard hardware torque  
specification chart.

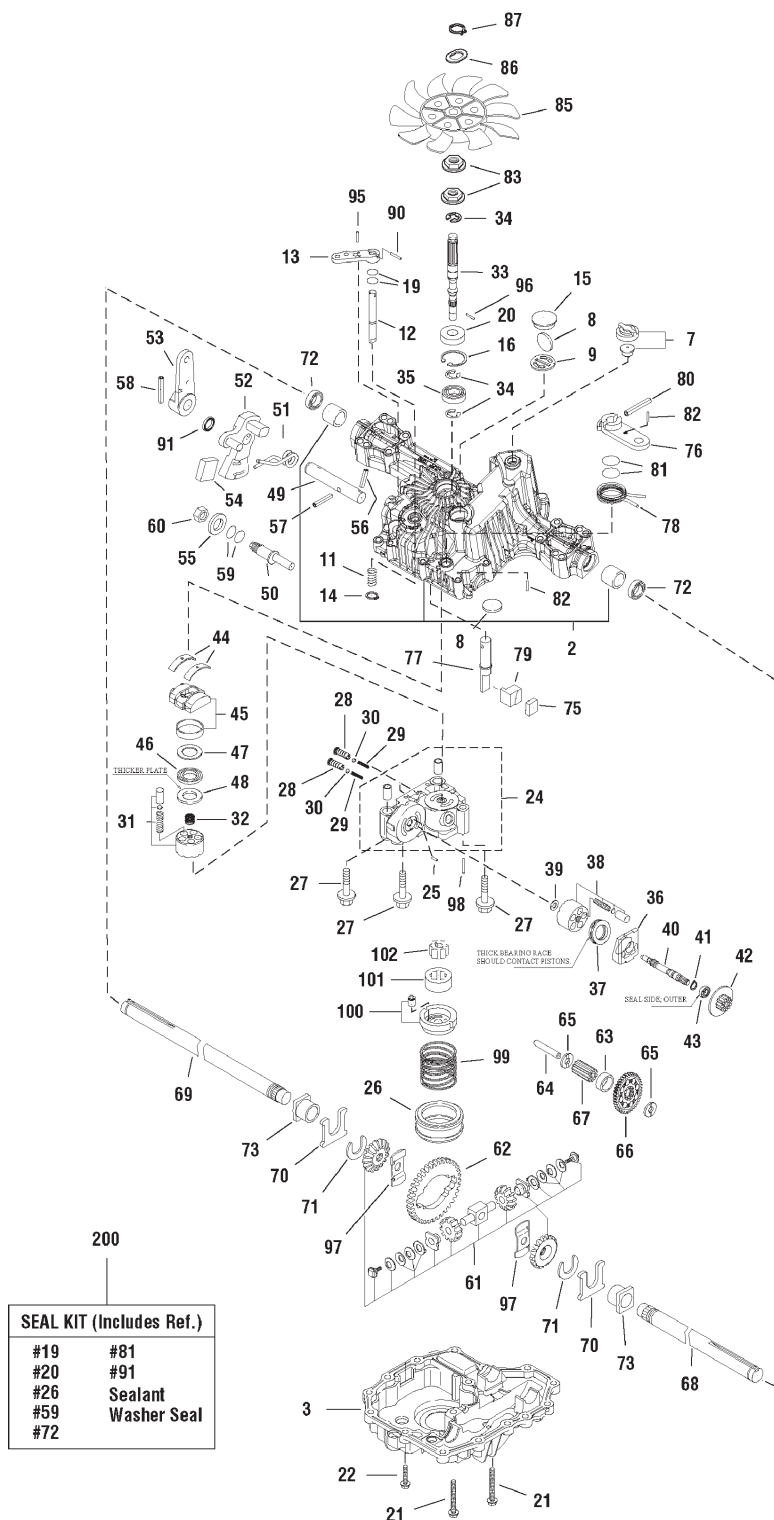

The above parts group applies to the following Mfg. Nos.:

- 2690947 - Broadmoor
- 2690947-01 - Broadmoor
- 2690948 - Broadmoor
- 2690949 - Broadmoor
- 2691111-00 - Broadmoor
- 2691112-00 - Broadmoor



## Transmission SERVICE PARTS - Tuff Torq K57A

REF NO	PART NO.	QTY.	DESCRIPTION
54	1724348	1	JERKY PLATE
55	1708689	1	WASHER
56	1724349	1	PIN, COTTER
57	1724296	1	PIN, SPRING
59	1707879	2	PACKING
58	1718100	1	PIN 6.0A x 4.0
60	1708692	1	NUT 12
61	1724955	1	GEAR & PINION ASSEMBLY
62	-----	1	*GEAR, FINAL CONTR TRAC
63	1724946	2	COLLAR, PINION
64	-----	1	*SHAFT, Reduction
65	1724948	2	WASHER, 12 x 32 x 3.2
66	1724949	1	GEAR, Reduction
67	1724950	1	PINION, Final
68	1724304	1	SHAFT, AXLE, Right
69	1724303	1	SHAFT, AXLE, Left
70	1718112	2	WASHER, Thrust
71	1718113	2	RING 17
72	1718111	2	SEAL 19 x 32 x 8
73	1718110	2	BUSHING 19 x 21
75	1724305	1	SHOE, Brake
76	1724306	1	ARM, Brake
77	-----	1	SHAFT, Brake
78	1724308	1	SPRING, RETURN B
79	1724309	1	BRAKE, Actuator
80	1724310	1	PIN
81	1708690	2	PACKING
82	1724311	2	PIN, Spring
83	1724312	2	COLLAR, Spline
85	1724314	1	FAN
86	1724315	1	LOCKWASHER
87	1724316	1	RING, Snap
90	1707839	1	PIN 3.0A x 20
91	1724318	1	OIL SEAL
95	1707839	1	PIN, Roll
97	1724956	2	WASHER, THRUST DIFF
98	-----	2	PIN, 3.0A x 18
99	-----	1	*SPRING, Charge
100	1724953	1	CHARGE PUMP CASE ASSEMBLY
200	1727542	1	SEAL KIT, K57

### Footnotes

\*Note: See your local authorized dealership for parts and warranty or contact Tuff Torq at [www.tufftorqservices.com](http://www.tufftorqservices.com) (U.S. 1-866-572-3441 Int'l 01-423-585-1977)

### The above parts group applies to the following Mfg. Nos.:

2690947 - Broadmoor  
 2690947-01 - Broadmoor  
 2690948 - Broadmoor  
 2690949 - Broadmoor  
 2691111-00 - Broadmoor

# Control Group - Cruise Control

NOTE: Unless noted otherwise, use the standard hardware torque specification chart.

0761986190

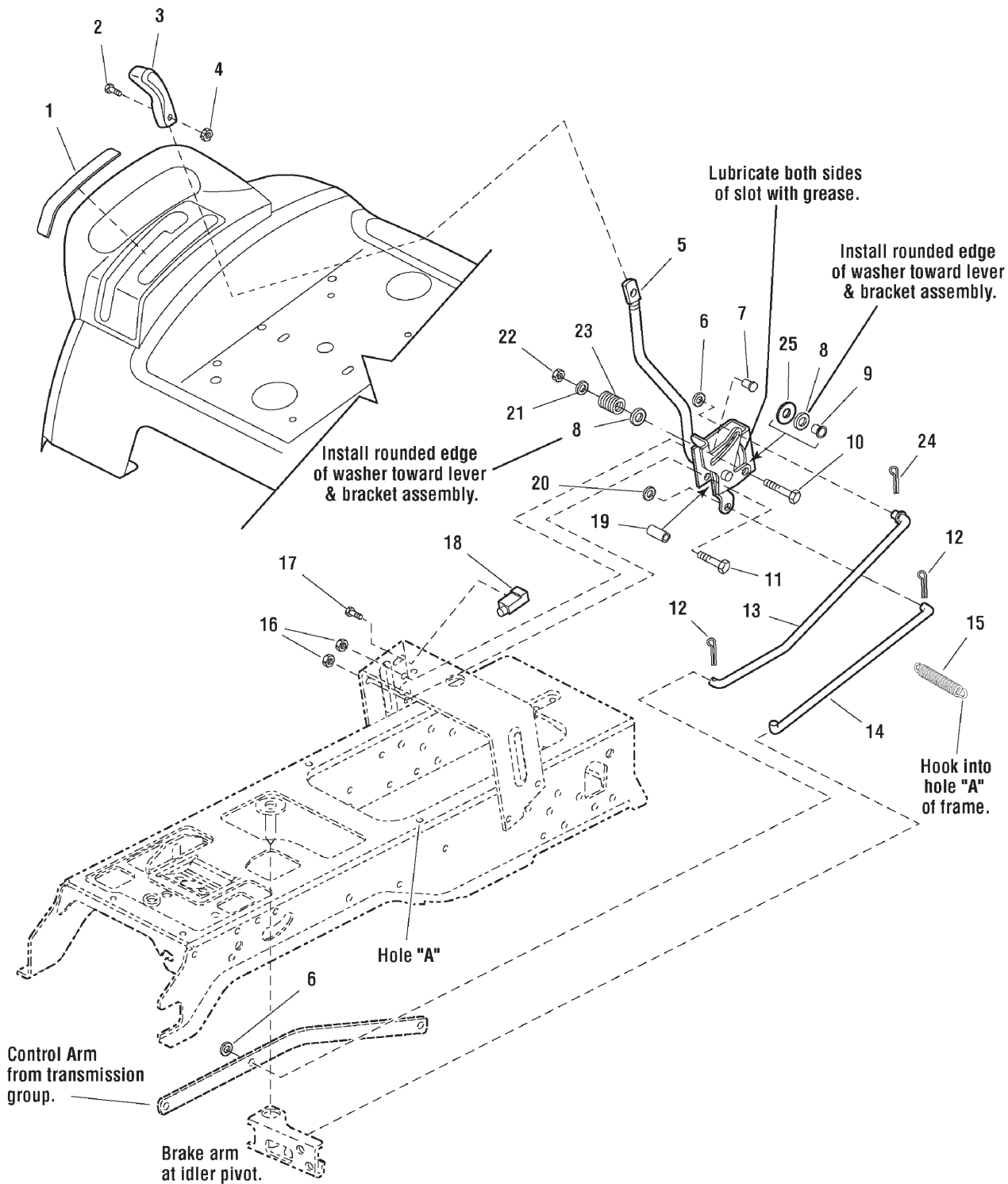

The above parts group applies to the following Mfg. Nos.:

- 2690947 - Broadmoor
- 2690947-01 - Broadmoor
- 2690948 - Broadmoor
- 2690949 - Broadmoor
- 2691111-00 - Broadmoor
- 2691112-00 - Broadmoor

## **Control Group - Cruise Control**

<b>REF NO</b>	<b>PART NO.</b>	<b>QTY.</b>	<b>DESCRIPTION</b>
1	1723713	1	DECAL, Cruise & Lift
2	1960666	1	SCREW, Torque Head Plus Socket Head, 1/4-20 x 7/8
3	1722303	1	KNOB, Cruise
4	1920397	1	NUT, Hex Lock ESNA Light, 1/4-20
5	1722003	1	LEVER & BRACKET ASSEMBLY, Cruise
6	1960103	2	WASHER, 3/8, Black
7	1931333	1	CARRIAGE BOLT, 5/16-18 x 3/4
8	1926192	2	WASHER, 9/16 x 1-1/4 x 1/8
9	1709043	1	SPACER, w/Flange, 11/32 x 15/32 x 3/4
10	1931342	1	CARRIAGE BOLT, 5/16-18 x 2 3/4
11	1960273	1	CARRIAGE BOLT, 5/16-18 x 2-1/4
12	1722460	2	PIN, Quick
13	1722117	1	ROD, Cruise
14	1733719	1	ROD, Return
15	2159106	1	SPRING, Cruise Return to Frame
16	1960636	2	NUT, Hex KEPS, 5/16-18
17	1960001	2	CAPSCREW, Hex Washer Head Plastite, 10-14 x 5/8
18	1717050	1	SWITCH, Push, Neutral Start, Gray
19	1722080	1	SPACER, 11/32 x 5/8 x 1-13/32
20	1919326	1	WASHER, 5/16, Black
21	1919381	1	WASHER, 5/16, Black
22	1919438	1	NUT, Hex Lock ESNA Light, 5/16-18
23	1677746	1	SPRING, Compression
24	1918447	1	PIN, Cotter
25	1705928	1	DISC, Friction

## **Footnotes**

---

### **The above parts group applies to the following Mfg. Nos.:**

2690947 - Broadmoor

2691112-00 - Broadmoor

2690947-01 - Broadmoor

2690948 - Broadmoor

2690949 - Broadmoor

2691111-00 - Broadmoor

## Controls Group

NOTE: Unless noted otherwise,  
use the standard hardware torque  
specification chart.

986599

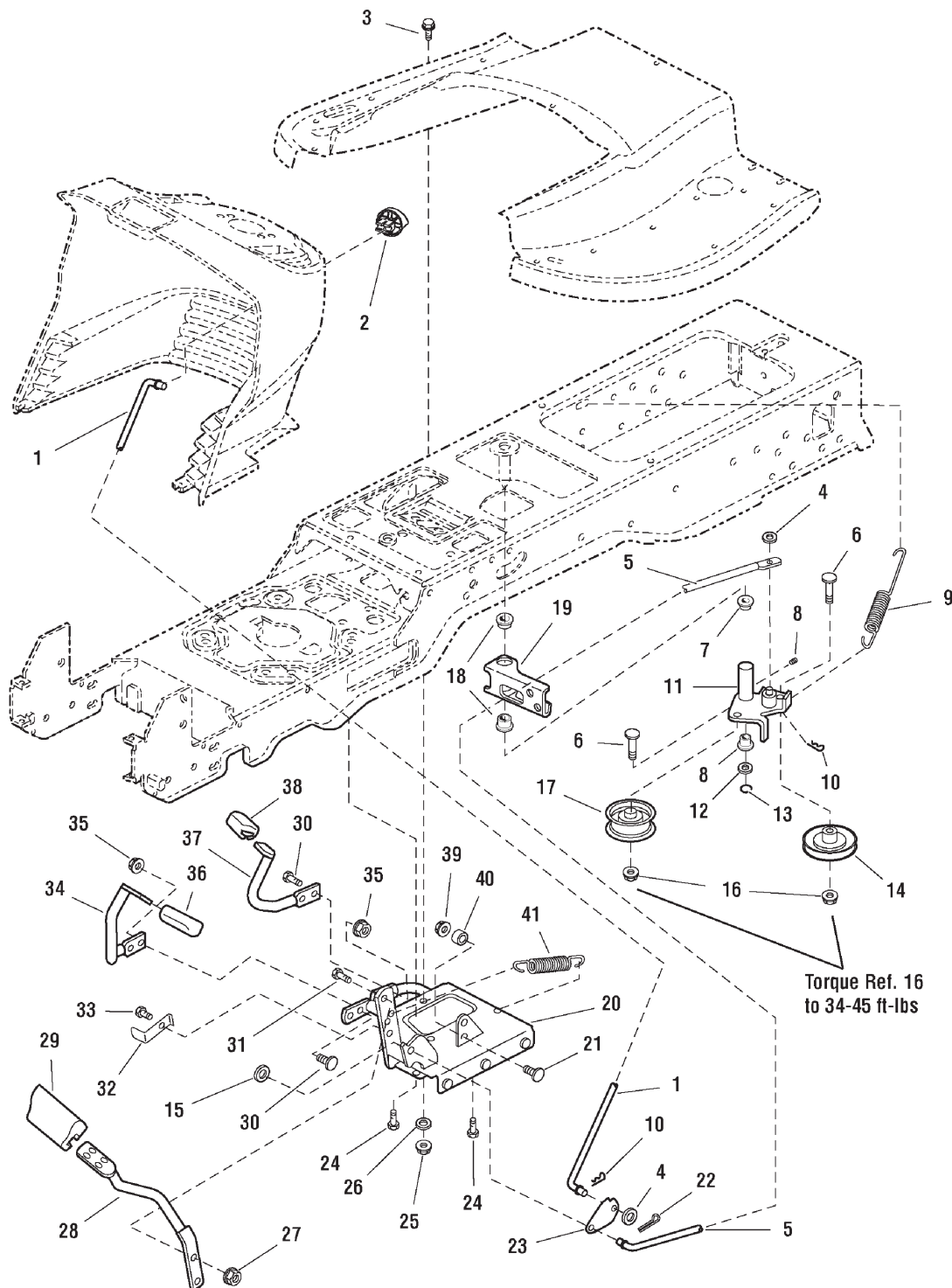

The above parts group applies to the following Mfg. Nos.:

2690947 - Broadmoor

2691112-00 - Broadmoor

2690947-01 - Broadmoor

2690948 - Broadmoor

2690949 - Broadmoor

2691111-00 - Broadmoor

## Controls Group

REF NO	PART NO.	QTY.	DESCRIPTION
1	1721353	1	ROD, Brake Lock
2	1721891	1	KNOB, Push On, Red Plastic "P"
3	1930591	1	CAPSCREW, Hex Flange Whiz Lock, 5/16-18 x 3/4
4	1919326	2	WASHER, 5/16, Black
5	1721476	1	ROD, Brake
6	1931353	2	BOLT, Carriage, 3/8-16 x 1 3/4
7	1663114	2	BUSHING, 5/8 x 3/4 x 3/4, Nylon
8	2821133	1	FITTING, Lube, 1/4
9	1725250	1	SPRING, Extension
10	1722460	3	PIN, Quick
11	1724917	1	ARM & HUB ASSEMBLY, Idler
12	1960020	1	WASHER, 5/8
13	1704420	1	RING, Clipping Extension
14	1721134	1	PULLEY, w/Bearing
15	1924940	1	WASHER, 3/8
16	1960687	2	NUT, Hex Flange ESNA, 3/8-16
17	1721133	1	PULLEY, Idler
18	1723237	2	BUSHING, 1 x 1-1/8 x 5/8, Nylon
19	1722513	1	ARM, Brake
20	1726763	1	PEDAL ASSEMBLY, Foot
21	1931320	1	BOLT, Carriage, 1/4-20 x 1-1/4
22	1918447	1	PIN, Cotter, Black
23	1721354A	1	LATCH, Brake
24	1664847SM	3	CAPSCREW, Hex Washer Head Taptite, 5/16-18 x 3/4
25	1919438	1	NUT, Hex Lock ESNA Light, 5/16-18
26	1919381	1	WASHER, 5/16, Black
27	1927557	2	NUT, Hex Flange Whiz Lock Large, 5/16-18
28	1722535A	1	PEDAL, Brake
29	1721577	1	PAD, Brake Pedal
30	1931334	4	BOLT, Carriage, 5/16-18 x 7/8
31	1921333	2	CAPSCREW, 5/16-18 x 1
32	1722083A	1	ACTUATOR, Switch 2.53" Long
33	1923683	1	CAPSCREW, Hex Washer Head Taptite, 3/8-16 x 3/4
34	1722070A	1	PEDAL, Forward
35	1960636	4	NUT, Hex KEPS, 5/16-18
36	1721675	1	PAD, Foot Pedal Forward
37	1722071A	1	PEDAL, Reverse
38	1721674	1	PAD, Foot Pedal Reverse
39	1920397	1	NUT, Hex Lock ESNA Light, 1/4-20
40	1686612	1	CAM, Roller
41	1721995	1	SPRING, Extension

## Footnotes

### The above parts group applies to the following Mfg. Nos.:

2690947 - Broadmoor  
 2690947-01 - Broadmoor  
 2690948 - Broadmoor  
 2690949 - Broadmoor  
 2691111-00 - Broadmoor

2691112-00 - Broadmoor

# Electrical Group

NOTE: Unless noted otherwise, use the standard hardware torque specification chart.

986604\_986604\_987654\_988581\_988886

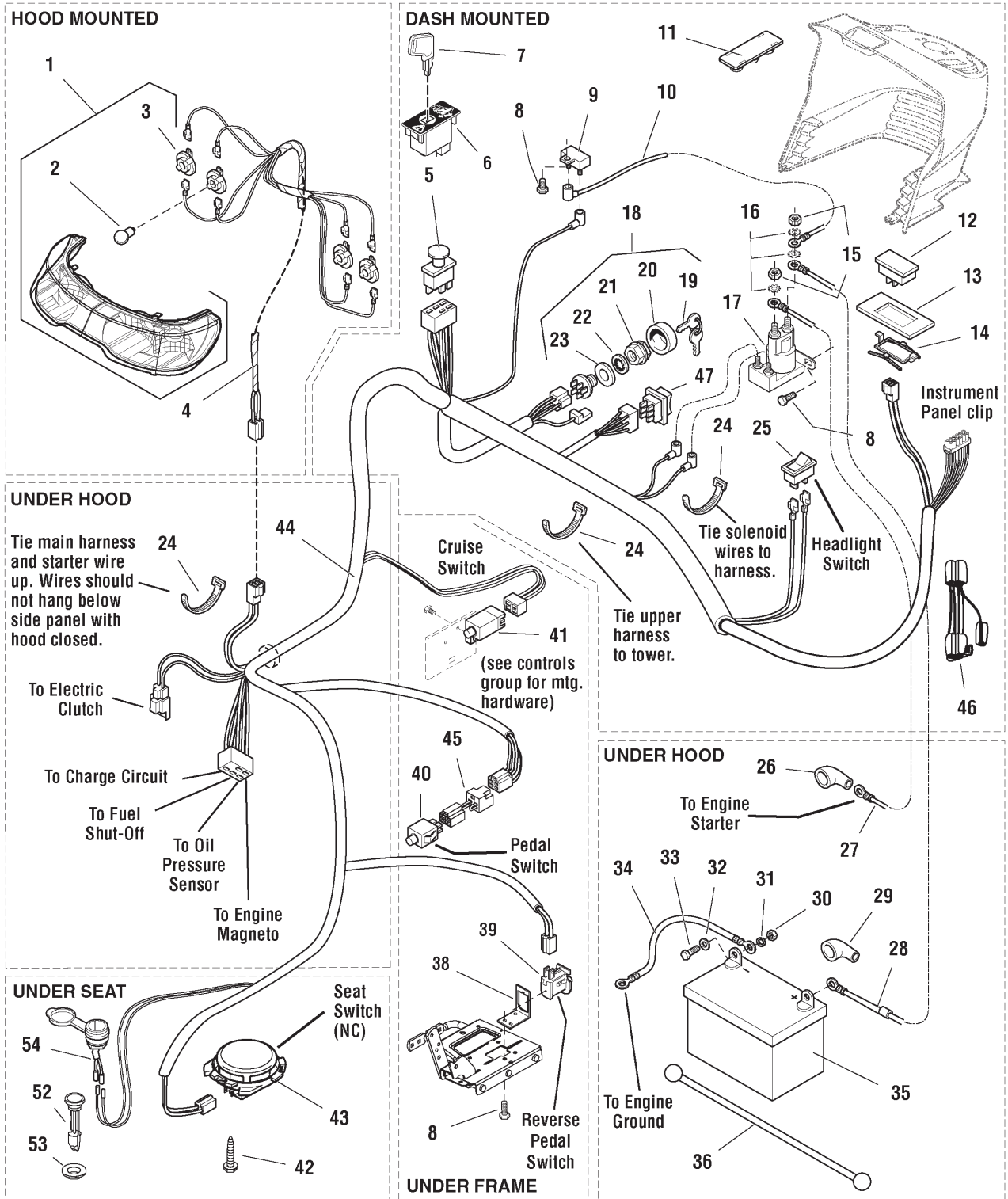

The above parts group applies to the following Mfg. Nos.:

- 2690947 - Broadmoor
- 2690947-01 - Broadmoor
- 2690948 - Broadmoor
- 2690949 - Broadmoor
- 2691111-00 - Broadmoor
- 2691112-00 - Broadmoor

## Electrical Group

REF NO	PART NO.	QTY.	DESCRIPTION
1	1721810	1	HEADLIGHT ASSEMBLY, 4 Bulb, (Includes Ref. Nos. 2 & 3)
2	1677371	4	BULB, Headlight, 12.8V
3	1723451	4	SOCKET ASSEMBLY, Headlight, Sealed
4	1722669	1	HARNESS, Headlight
5	1722887	1	SWITCH, PTO Push/Pull Symbols
6	1726556	1	SWITCH, RMO Module Only
7	1726557	1	KEY, RMO Module, Plastic
8	1925003	2	CAPSCREW, Hex Washer Head Taptite, 1/4-20 x 1/2, Black
9	1665238	1	BREAKER, Circuit, 12 Volt 20 Amps
10	1665237	1	WIRE, 12GA 5-15/16 Long, Red
11	1722611	1	PLUG, Hole, Square (18HP & 20HP Models Only)
12	1731184	1	HOUR METER
13	1725524	1	PLUG, Dash (Includes Ref. Nos. 12)
14	1725835	1	CLIP, Hour Meter (Service Only)
15	2820263	2	NUT, Hex, 5/16-24
16	2820426	3	LOCKWASHER, External Tooth, 5/16
17	1722739	1	SOLENOID
18	1686734	1	SWITCH ASSEMBLY, Ignition, 6 Pin, (Includes Ref. Nos. 17, 18, 19, 20 & 21)
19	1717163	1	KEYS, Set of 2
20	1717550	1	COVER, For Ignition Switch, Plastic
21	1717549	1	NUT, Hex Flange, 5/8-32, Ignition Switch
22	1960547	1	LOCKWASHER, Internal Tooth, 5/8, Thin
23	2101025	1	WASHER, Shim
24	1701011	3	TIE, Strap, 7-5/16 Long
25	1716951	1	SWITCH, Headlights , 2 Terminal
26	1713535	1	BOOT, Insulator Cable Terminal, 1-15/16 Long, Red
27	1721830	1	CABLE, #6 x 25" Long, Ring Terminals
28	1603618	1	CABLE, #6 x 8" Long, Ring Terminals
29	1677296	1	BOOT, Insulator Battery Terminal
30	2816622	3	NUT, Hex, 1/4-20
31	2816964	2	LOCKWASHER, 1/4
32	2821319	2	WASHER, 1/4
33	2823341	2	CAPSCREW, Hex Head, 1/4-20 x 3/4
34	1713163	1	CABLE, #6 x 26 Long, Ring Terminal
35	1685215	1	BATTERY, 12 Volt
36	1722009	1	STRAP, Battery, 14 Long, Rubber
37	1929000	2	CAPSCREW, Hex Head Taptite, 1/4-20 x 3/8
38	1726810A	1	BRACKET, Switch Mount
39	1732004	1	SWITCH, Reverse Pedal
40	1732006	1	SWITCH, Push Button, Foot Pedal
41	1717050	1	SWITCH, Cruise Control, Grey, NO
42	1960536	2	CAPSCREW, Hex Washer Head Plastite, 1/4 x 1/2
43	1716368	1	SWITCH, Seat, Grey, NC
44	1730192	1	HARNESS, Wiring

### Footnotes

---

#### The above parts group applies to the following Mfg. Nos.:

2690947 - Broadmoor  
2690947-01 - Broadmoor  
2690948 - Broadmoor  
2690949 - Broadmoor  
2691111-00 - Broadmoor

2691112-00 - Broadmoor

# Electrical Group

NOTE: Unless noted otherwise, use the standard hardware torque specification chart.

986604\_986604\_987654\_988581\_988886

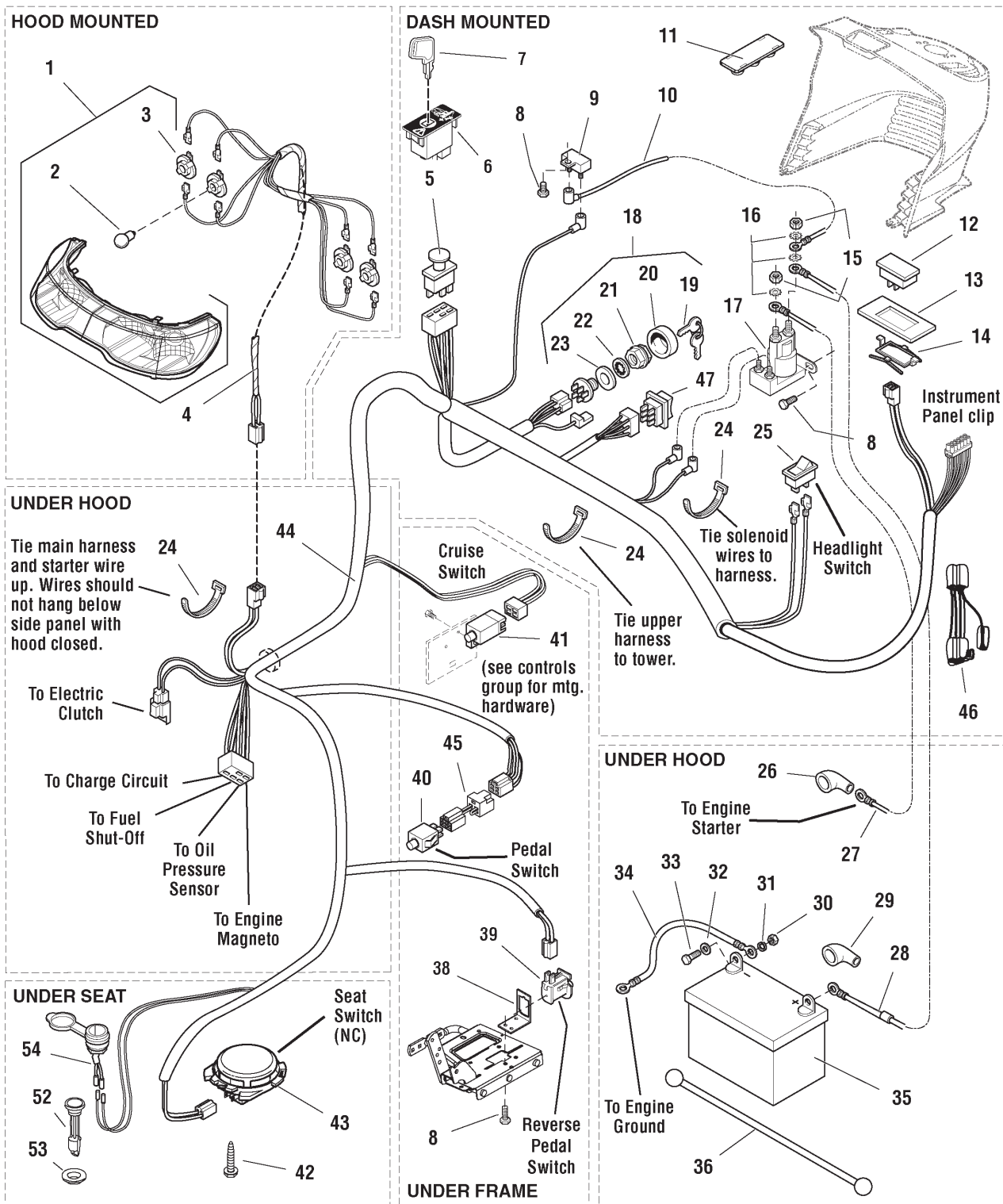

The above parts group applies to the following Mfg. Nos.:

- 2690947 - Broadmoor
- 2690947-01 - Broadmoor
- 2690948 - Broadmoor
- 2690949 - Broadmoor
- 2691111-00 - Broadmoor
- 2691112-00 - Broadmoor



## **Electrical Group**

---

<b>REF NO</b>	<b>PART NO.</b>	<b>QTY.</b>	<b>DESCRIPTION</b>
45	1734025	1	WIRING ASSEMBLY, All Conditions Shutdown (CE/Export)
46	1739717	1	HARNESS, Jumper Wire (22HP Models Only)
47	1716329	1	SWITCH, Electric Lift Rocky (22HP Models Only)
52	1722300	1	GAUGE, Fuel
53	1722337	1	GROMMET
54	1725302	1	OUTLET. 12V

## **Footnotes**

---

### **The above parts group applies to the following Mfg. Nos.:**

2690947 - Broadmoor  
2690947-01 - Broadmoor  
2690948 - Broadmoor  
2690949 - Broadmoor  
2691111-00 - Broadmoor  
2691112-00 - Broadmoor

## Hood, Grille & Dash Group

NOTE: Unless noted otherwise,  
use the standard hardware torque  
specification chart.

986608

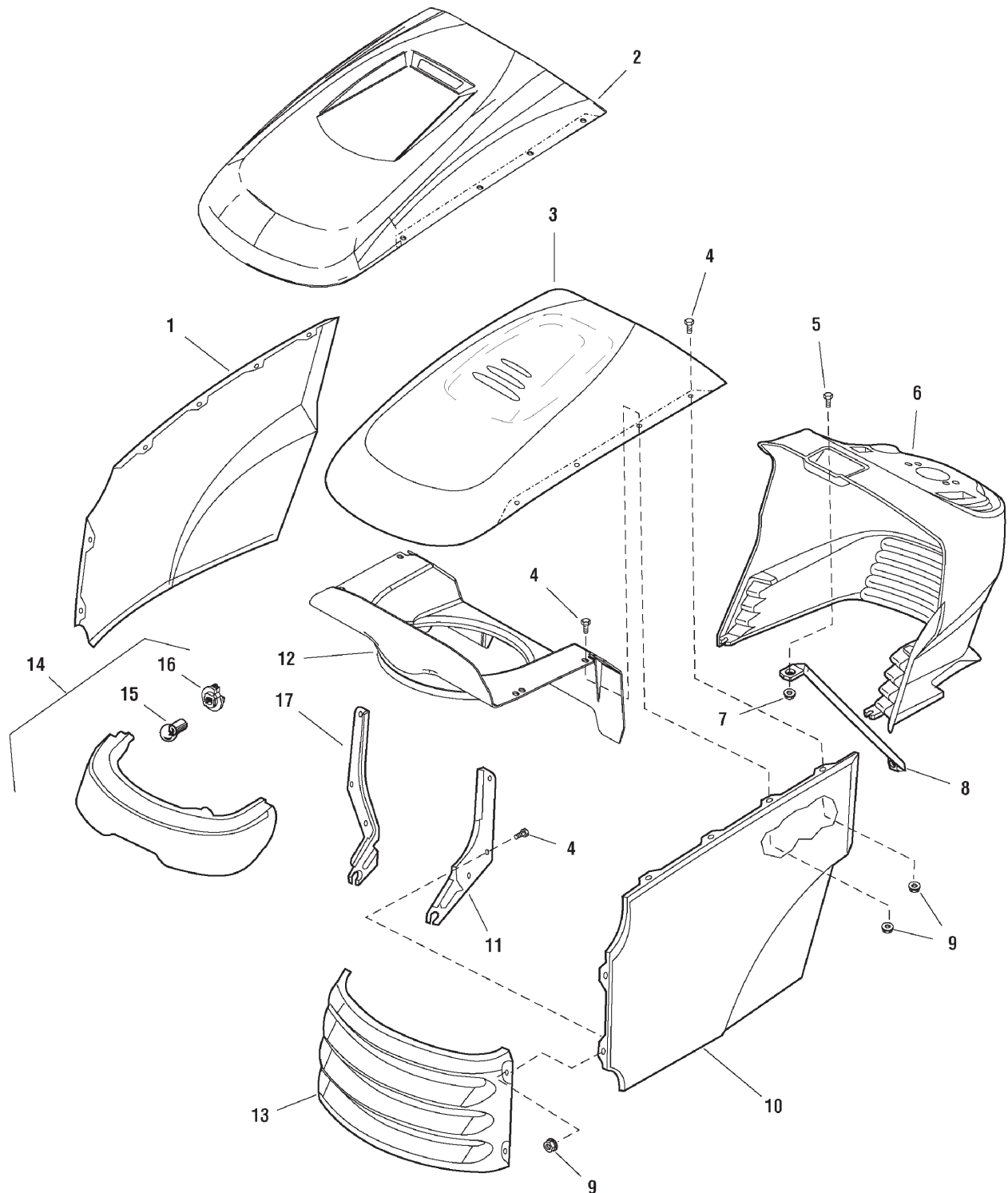

The above parts group applies to the following Mfg. Nos.:

2690947 - Broadmoor

2691112-00 - Broadmoor

2690947-01 - Broadmoor

2690948 - Broadmoor

2690949 - Broadmoor

2691111-00 - Broadmoor

## Hood, Grille & Dash Group

REF NO	PART NO.	QTY.	DESCRIPTION
1	1721804C	1	PANEL, RH Side, Orange
1	1721804D	1	PANEL, RH Side, Red
2	1728031D	1	HOOD, with Scoop, Red
3	1722110C	1	HOOD, with Louvers, Orange
3	1722110D	1	HOOD, with Louvers, Red
4	1960295	12	CAPSCREW, Hex Head Flange Lock, 1/4-20 x 5/8
5	1960392	1	SCREW, Phillips Head, #10-24 x 1/2
6	1687054	1	DASHBOARD, RMO, Black
6	1687055	1	DASHBOARD, RMO with Hydra Lift Slot, Black
7	1933896	1	NUT, Hex Nylock, #10-24
8	1723123	1	ROD, Dash Support
9	1930641	12	NUT, Hex Flange Lock, 1/4-20
10	1721803C	1	PANEL, LH Side, Orange
10	1721803D	1	PANEL, LH Side, Red
11	1721808A	1	HINGE, LH
12	7102326	1	DUCT, Air Inlet
13	1721802C	1	GRILLE, Orange
13	1721802D	1	GRILLE, Red
14	1721810	1	HEADLIGHT ASSEMBLY (Includes Ref. Nos. 15 & 16)
15	1677371	4	BULB, Headlight
16	1723451	4	SOCKET, Headlight
17	1721809A	1	HINGE, RH

## Footnotes

---

### The above parts group applies to the following Mfg. Nos.:

2690947 - Broadmoor  
2690947-01 - Broadmoor  
2690948 - Broadmoor  
2690949 - Broadmoor  
2691111-00 - Broadmoor

2691112-00 - Broadmoor

# Seat & Seat Deck Group - EVAP Compliant

2989509

**NOTE:** Unless noted otherwise,  
use the standard hardware torque  
specification chart.

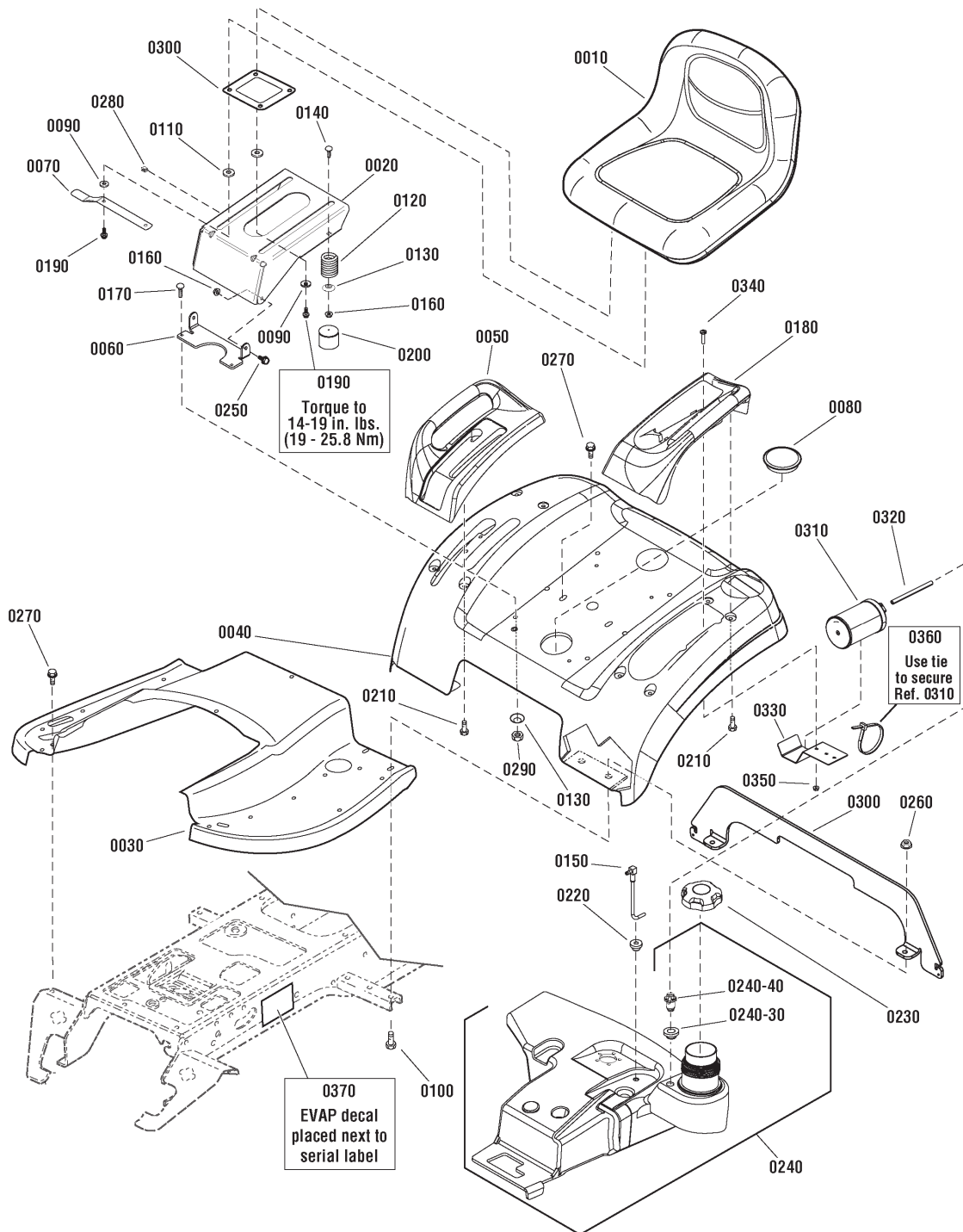

**The above parts group applies to the following Mfg. Nos.:**

- 2690947 - Broadmoor
- 2690947-01 - Broadmoor
- 2690948 - Broadmoor
- 2690949 - Broadmoor
- 2691111-00 - Broadmoor
- 2691112-00 - Broadmoor

## Seat & Seat Deck Group - EVAP Compliant

REF NO	PART NO.	QTY.	DESCRIPTION
0010	1733382	1	SEAT, 15" Back
0020	1727265A	1	SUPPORT, Seat
0030	1722105D	1	TUNNEL, Red
0030	1722105C	1	TUNNEL, Orange
0040	1722106D	1	DECK, Seat, Red
0040	1722106C	1	DECK, Seat, Orange
0050	1722108	1	POD, RH with 2 Slots
0060	1738233A	1	SUPPORT, Seat Pivot
0070	1727268	1	LATCH, Seat
0080	1722309	2	PLUG, Plastic
0090	1919381	4	WASHER, 5/16 x 1
0100	1930591	8	CAPSCREW, Hex Flange Whiz Lock, 5/16-18 x 3/4
0110	1731300	4	SPACER, 5/16 x 1-1/4
0120	1704728	2	SPRING, Compression, 2" Long
0130	1709256	4	WASHER, Spring, 5/16 x 1-1/4
0140	1960282	2	BOLT, Carriage, 5/16-18 x 3/4, G5
0150	1726902	1	TUBE & ELBOW ASSEMBLY
0160	1960686	4	NUT, Hex Flange, 5/16-18, ESNA
0170	1931334	2	BOLT, Carriage, 5/16-18 x 7/8, G5
0180	1729711	1	POD, with Cup Holder, LH
0190	1930595	4	CAPSCREW, Hex Flange Whiz Lock, 5/16-18 x 1-1/4
0200	1704724	2	COVER, Spring, 1-1/2 Long
0210	2860664	8	CAPSCREW, Hex Washer Head, 1/4-20 x 5/8
0220	1654930	1	BUSHING, 3/8 x 9/16 x 5/8, Rubber
0230	5103005	1	CAP, Gas, Vent Out, 3-1/2"
0240	1751622	1	TANK, Fuel
0240-30	209043	1	GROMMET
0240-40	7104638	1	REMOTE VENT ASSEMBLY. No Valve
0250	1729576	2	BOLT, Shoulder, 5/16-18 x 1-1/8
0260	1931277	4	NUT, Hex Flange Whiz Lock, 5/16-18
0270	1930601	4	CAPSCREW, Hex Flange Washer Head, Taptite, 5/16-18 x 5/8
0280	2172434	1	CLIP, Wire
0290	1919438	2	NUT, Hex Lock, ESNA Light, 5/16-18
0300	1739571A	1	SPACER PLATE
0310	1751599	1	CARBON CANISTER, 300cc
0320	7700552X4	1	VAPOR HOSE, 4mm
0330	1752099A	1	BRACKET, Canister Mounting
0340	1960589	2	SCREW, Phillips, #10-24 x 3/4
0350	1960591	2	NUT, Hex, KEPS, #10-24
0360	1701011	1	TIE, Self Locking, 15"
0370	1753995	1	DECAL, EVAP

### Footnotes

---

#### The above parts group applies to the following Mfg. Nos.:

2690947 - Broadmoor  
2690947-01 - Broadmoor  
2690948 - Broadmoor  
2690949 - Broadmoor  
2691111-00 - Broadmoor  
2691112-00 - Broadmoor

# Lift Group - Manual

0764986412

**NOTE:** Unless noted otherwise,  
use the standard hardware torque  
specification chart.

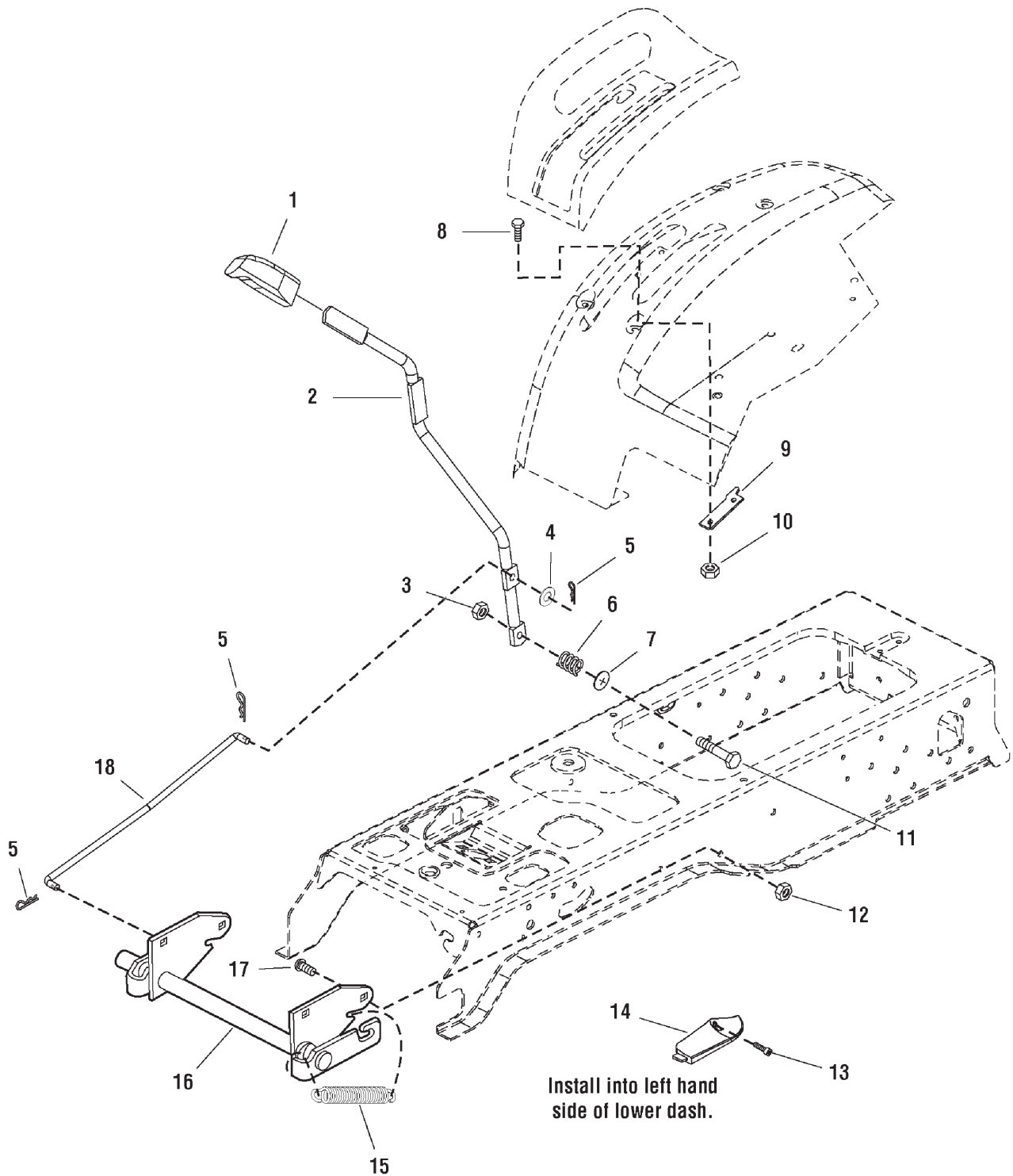

**The above parts group applies to the following Mfg. Nos.:**

- 2690948 - Broadmoor
- 2690949 - Broadmoor
- 2691112-00 - Broadmoor

## **Lift Group - Manual**

---

<b>REF NO</b>	<b>PART NO.</b>	<b>QTY.</b>	<b>DESCRIPTION</b>
1	1722302	1	GRIP, Black Vinyl
2	1722024A	1	ROD, Lift Lever with Flats
3	1930645	1	NUT, Hex Flange Lock, 3/8-16
4	1924940	1	WASHER
5	1722460	2	PIN, Quick
6	2162085	1	SPRING, Compression
7	1723866	1	NUT, Push, 3/8
8	1923341	2	CAPSCREW, Hex Head, 1/4-20 x 3/4
9	1722284A	1	QUADRANT
10	1920397	2	NUT, Hex Lock ESNA, 1/4-20
11	1923701	1	CAPSCREW, Hex Head, 3/8-16 x 2
12	1960636	4	NUT, KEPS Lock, 5/16-18
13	1722607	1	SCREW, Torx Head, # 8-16 x 1/2
14	1722285	1	COVER, Dash
15	2156302	1	SPRING, Extension, 4-1/8
16	1727437A	1	LIFT SHAFT ASSEMBLY,
17	1931333	4	CARIAGE BOLT, 5/16-18 x 3/4
18	1725638	1	ROD, Lift

## **Footnotes**

---

### **The above parts group applies to the following Mfg. Nos.:**

2690948 - Broadmoor

2690949 - Broadmoor

2691112-00 - Broadmoor

# Lift Group - Manual with Cruise Control

986780

NOTE: Unless noted otherwise, use the standard hardware torque specification chart.

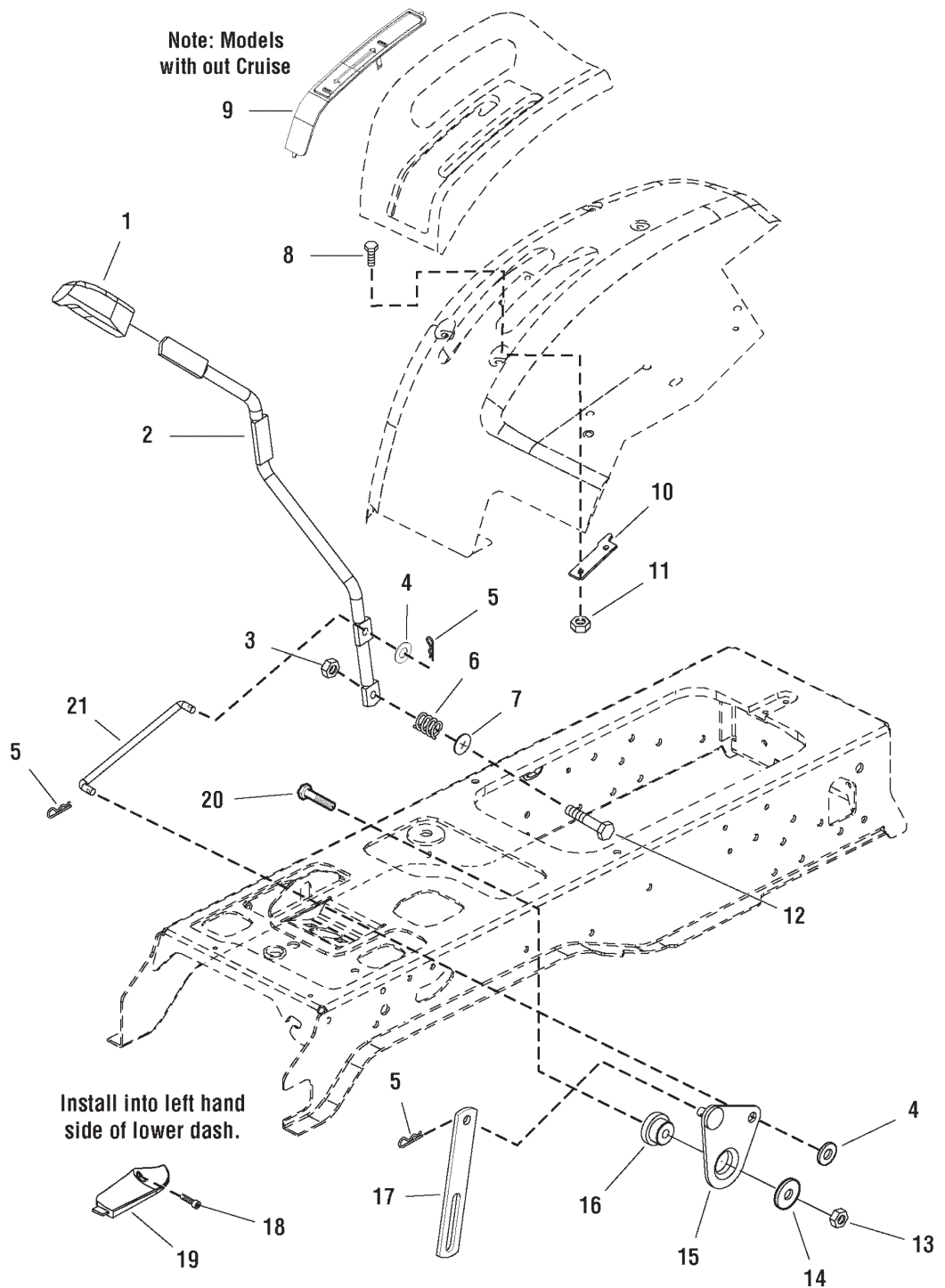

The above parts group applies to the following Mfg. Nos.:

- 2690947 - Broadmoor
- 2690947-01 - Broadmoor
- 2691111-00 - Broadmoor



## **Lift Group - Manual with Cruise Control**

<b>REF NO</b>	<b>PART NO.</b>	<b>QTY.</b>	<b>DESCRIPTION</b>
1	1722302	1	GRIP, Black Vinyl
2	1722024A	1	ROD, Lift Lever with Flats
3	1930645	1	NUT, Hex Flange Lock, 3/8-16
4	1924940	1	WASHER
5	1722460	2	PIN, Quick
6	2162085	1	SPRING, Compression
7	1723866	1	NUT, Push, 3/8
8	1923341	2	CAPSCREW, Hex Head, 1/4-20 x 3/4
9	1722313	1	PLUG, Lift Cover (Models without Cruise Control)
10	1722284A	1	QUADRANT
11	1920397	2	NUT, Hex Lock ESNA, 1/4-20
12	1923701	1	CAPSCREW, Hex Head, 3/8-16 x 2
13	1919438	4	NUT, ESNA Lock, 5/16-18
14	1960044	1	WASHER, Flat, 5/16 x 1-1/4
15	1722491	1	CAM ASSEMBLY, Lift
16	1704629	1	SPACER
17	1727083A	1	LINK, Lift Upper
18	1722607	1	SCREW, Torx Head, # 8-16 x 1/2
19	1722285	1	COVER, Dash
20	1921977	4	CAPSCREW, Hex Head, 5/16-18 x 1-1/4
21	1721789	1	ROD, Lift

### **Footnotes**

---

**The above parts group applies to the following Mfg. Nos.:**

2690947 - Broadmoor

2690947-01 - Broadmoor

2691111-00 - Broadmoor

## Wheels & Tires Group

W986614

NOTE: Unless noted otherwise,  
use the standard hardware torque  
specification chart.

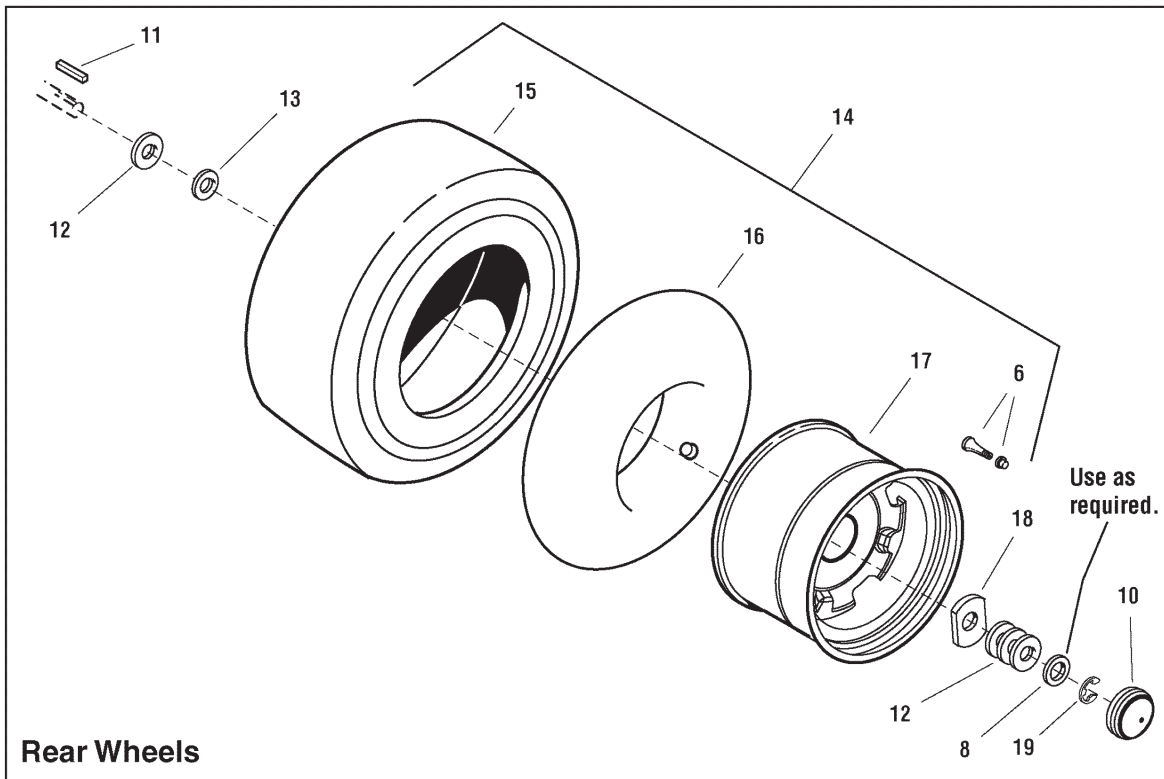
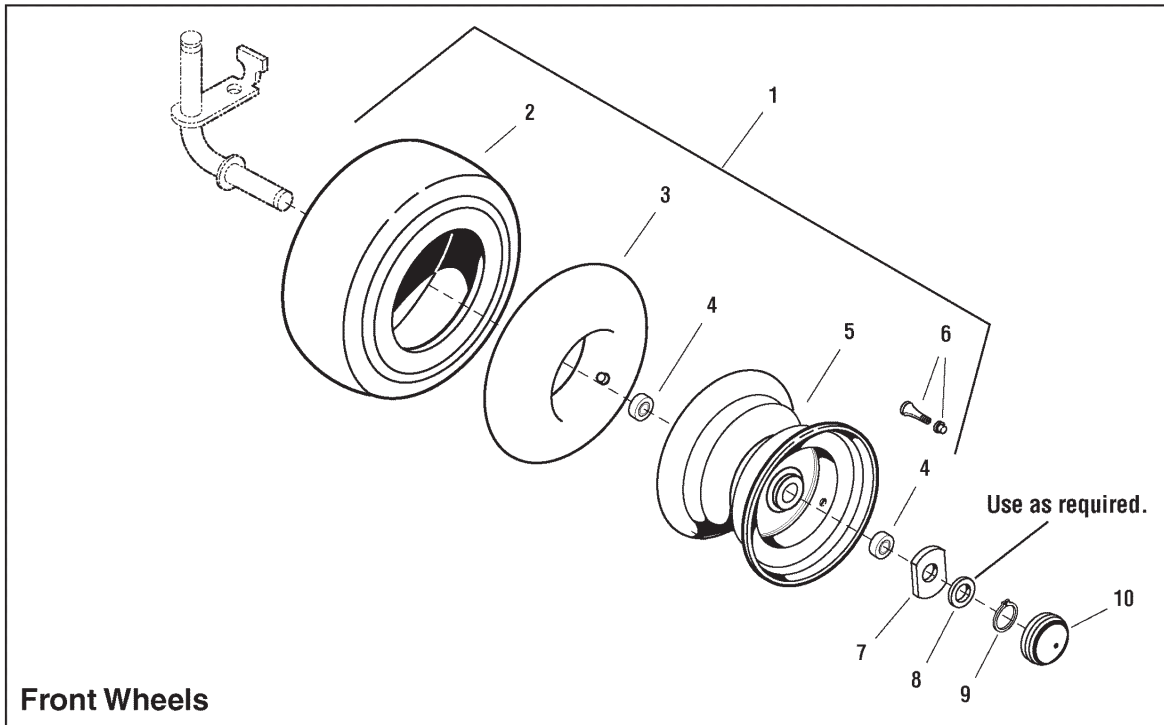

The above parts group applies to the following Mfg. Nos.:

2690947 - Broadmoor

2691112-00 - Broadmoor

2690947-01 - Broadmoor

2690948 - Broadmoor

2690949 - Broadmoor

2691111-00 - Broadmoor

## ***Wheels & Tires Group***

<b>REF NO</b>	<b>PART NO.</b>	<b>QTY.</b>	<b>DESCRIPTION</b>
1	1732202	2	WHEEL & TIRE ASSEMBLY, Front, (Includes Ref. Nos. 2, 3, 4, 5, & 6)
2	1723882	1	TIRE, 15 x 6, Super Turf
3	1664090	1	TUBE, Tire, Front, 4.10/3.50
4	1717056	2	BEARING, Ball
5	1722837	1	WHEEL, 4-1/2" x 6"
6	2172353	4	VALVE STEM & CAP ASSEMBLY
7	1722726	2	WASHER, Flat 1 (Double D)
8	1919394	4	WASHER, 1, (As Required for All Front)
9	2832577	2	RING, Retaining, External #98
10	1722676	4	CAP, Hub, Gray
11	1729279	2	KEY, Parellel, 3/16 x 3/16 x 1-1/2
11	5048409	2	KEY, Parellel, 3/16 x 3/16 x 2-1/2
12	2860202	4	WASHER, 3/4
13	1960114	2	WASHER
14	1726491	2	WHEEL & TIRE ASSEMBLY, (Includes Ref. Nos. 6, 15, 16 & 17)
15	1727136	1	TIRE, 22 x 10, 10 Super Turf
16	2173477	1	TUBE, Tire, 20 x 8, Rear
17	1726492	1	WHEEL, 7 x 9.97, W/ 3/4 OD Shaft
18	1722717	2	WASHER, Special
19	2827794	2	RING, "E" External

## **Footnotes**

---

### **The above parts group applies to the following Mfg. Nos.:**

2690947 - Broadmoor  
2690947-01 - Broadmoor  
2690948 - Broadmoor  
2690949 - Broadmoor  
2691111-00 - Broadmoor

2691112-00 - Broadmoor

## Decals - Brand & Model

B986614

NOTE: Unless noted otherwise,  
use the standard hardware torque  
specification chart.

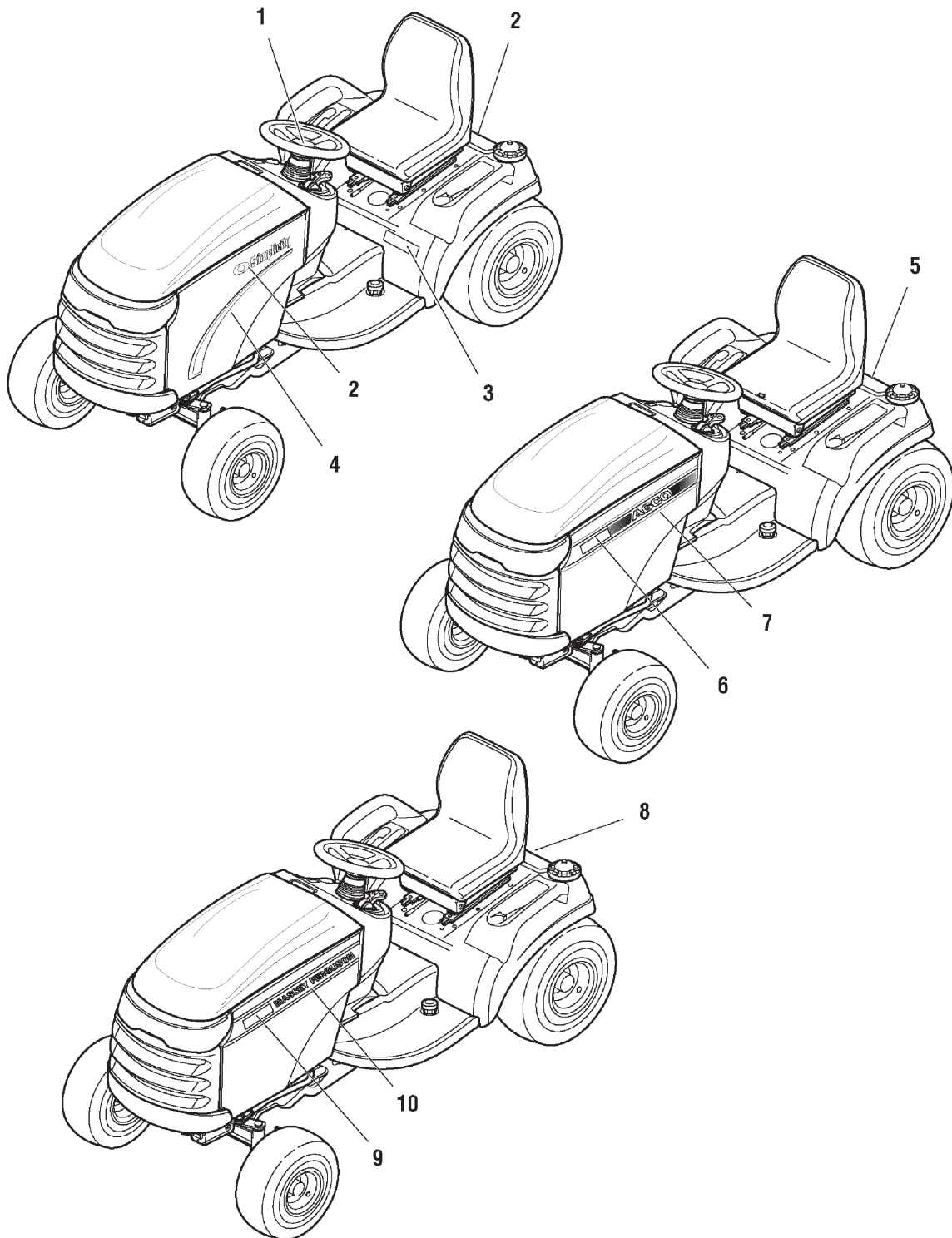

The above parts group applies to the following Mfg. Nos.:

2690947 - Broadmoor

2691112-00 - Broadmoor

2690947-01 - Broadmoor

2690948 - Broadmoor

2690949 - Broadmoor

2691111-00 - Broadmoor

## Decals - Brand & Model

REF NO	PART NO.	QTY.	DESCRIPTION
1	1731418	1	DECAL, ICON Simplicity, Orange
2	1722551	3	DECAL, Simplicity, Silver & Blue w/Icon
3	1722776	1	DECAL, Broadmoor, Silver & Blue
4	1722773	1	DECAL, Hood Stripe, RH, Simplicity, Blue & Silver
4	1722774	1	DECAL, Hood Stripe, LH, Simplicity, Blue & Silver
5	1708926	1	DECAL, AGCO, Logo Black, Chrome, Orange
6	1727069	1	DECAL, 1620, White, AGCO
7	1722818	1	DECAL, Hood Stripe, RH, AGCO
7	1722817	1	DECAL, Hood Stripe, LH, AGCO
8	1714363	1	DECAL, Massey Ferguson Logo, 3 Triangles
9	1725646	1	DECAL, 2618, Black, Massey Ferguson
9	1728112	1	DECAL, 2618, Cool Grey, Massey Ferguson
9	1727070	2	DECAL, 2620, Black, Massey Ferguson
9	1728054	2	DECAL, 2620, Cool Grey, Massey Ferguson
9	1750455	2	DECAL, 2622, Cool Grey, Massey Ferguson
10	1727783	1	DECAL, Hood Stripe, LH, Massey Ferguson
10	1727784	1	DECAL, Hood Stripe, RH, Massey Ferguson

## Footnotes

---

### The above parts group applies to the following Mfg. Nos.:

2690947 - Broadmoor  
2690947-01 - Broadmoor  
2690948 - Broadmoor  
2690949 - Broadmoor  
2691111-00 - Broadmoor  
2691112-00 - Broadmoor



## Decals - Safety & Common

REF NO	PART NO.	QTY.	DESCRIPTION
1	1722806	1	DECAL, Ignition Switch Symbols, White/Black
2	1718025	1	DECAL, Automatic Control Traction
3	1722779		DECAL, 18HP
3	1722780	1	DECAL, 20HP
4	1726923	1	DECAL, Tunnel Cover, Danger Slopes/Blades
4	1734027	1	DECAL, Tunnel Cover, Danger Slopes/Blades, (Export)
5	1727014	1	DECAL, Drive Belts, Mower Blades
6	1723296	2	DECAL, Protective Sticker
7	*	1	LABEL, Decibel, Power Mass (Export)
8	*	1	DECAL, I.D. Plate
9	1720454	1	DECAL, Touch Up Paint (Orange)
9	1725072	1	DECAL, Touch Up Paint (Red)
10	*	1	DECAL, Patent
12	1723160	1	DECAL, Transmission Release Valve
12	1730202	1	DECAL, Transmission Release Valve
13	1720389	2	DECAL, Danger Rotating Blades (Export)
14	1704276	1	DECAL, Danger Do Not Put Hands/Feet in Mower
15	1722771	1	DECAL, Free Floating Mower, Silver
16	*	1	DECAL, OPEI Certified
17	1722787	1	DECAL, 38", Silver on Black with Stripe
17	1722788	1	DECAL, 40", Silver on Black with Stripe
17	1722789	1	DECAL, 44", Silver on Black with Stripe
17	1722790	1	DECAL, 50", Silver on Black with Stripe
18	1704277	1	DECAL, Danger Do Not Operate Without Deflector
19	1721197	1	DECAL, Height of Cut, 38", 44" & 50"
20	1720919	1	DECAL, Height of Cut, 40"
21	1723143	1	DECAL, Deck Lift (Not Shown)

## Footnotes

---

### The above parts group applies to the following Mfg. Nos.:

2690947 - Broadmoor

2691112-00 - Broadmoor

2690947-01 - Broadmoor

2690948 - Broadmoor

2690949 - Broadmoor

2691111-00 - Broadmoor

# 44" Mower Deck - Clutch & Support Group

NOTE: Unless noted otherwise, use the standard hardware torque specification chart.

983858

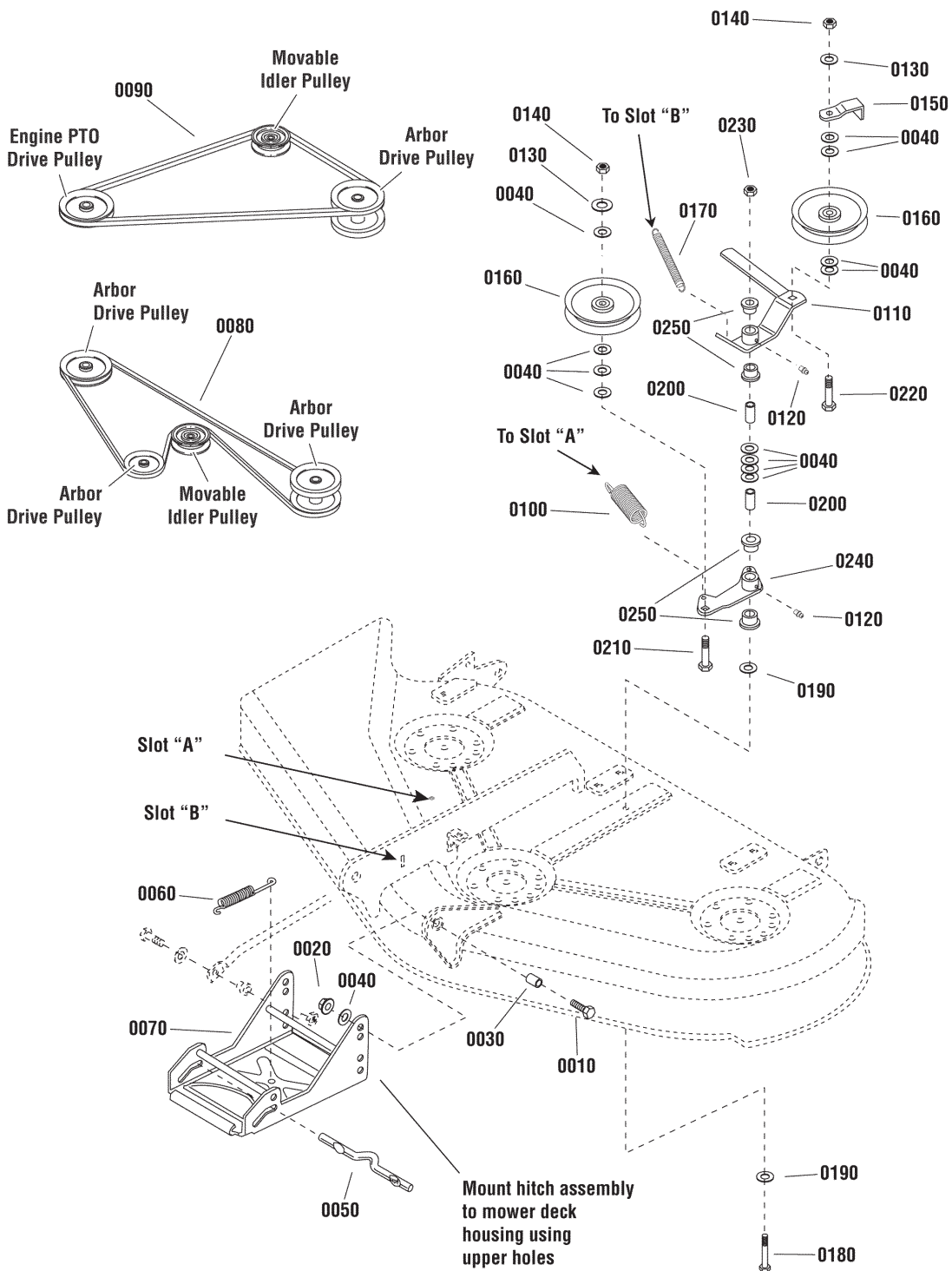

The above parts group applies to the following Mfg. Nos.:

- 1695727 - 44" Mower
- 2690947 - Broadmoor
- 2690947-01 - Broadmoor
- 2691111-00 - Broadmoor



## 44" Mower Deck - Clutch & Support Group

REF NO	PART NO.	QTY.	DESCRIPTION
0010	1921968	2	CAPSCREW, Hex Head, 3/8-16 x 1-3/8
0020	2860681	2	NUT, Hex Toplock Spirallock Flange, 3/8-16
0030	2157081	2	SPACER, 3/8 x 3/4 x 1/2
0040	1924940	14	WASHER, 3/8
0050	1715759	1	ROD, Latch
0060	2156302	1	SPRING
0070	1707432A	1	HITCH ASSEMBLY
0080	1721532	1	V-BELT, Arbor Drive
0090	1601672	1	V-BELT, Mower Drive
0100	1656936	1	SPRING
0110	1704658	1	LEVER ASSEMBLY, Idler
0120	2812808	2	GREASE FITTING
0130	1916965	2	WASHER, Lock, 3/8
0140	1916950	1	NUT, Hex Flange, 3/8-16, MAC Lock Large, Black
0150	1677135A	1	BELT STOP, Idler
0160	1724387	2	PULLEY, Idler
0170	1715435	1	SPRING
0180	1923938	1	CAPSCREW, Hex Head, 3/8-16 x 3-1/2
0190	1924356	2	WASHER, 3/8, Black
0200	1674669	2	SPACER, 25/64 x 5/8 x 1-1/8, Case Hardened
0210	1931352	1	CARRIAGE BOLT, 3/8-16 x 1-1/2
0220	1960315	1	CARRIAGE BOLT, 3/8-16 x 2
0230	1960339	2	NUT, Hex, 3/8-16
0240	1718561	1	LEVER ASSEMBLY, Idler Arm
0250	1676148	4	BUSHING, 5/8 x 3/4

### Footnotes

---

#### The above parts group applies to the following Mfg. Nos.:

1695727 - 44" Mower  
2690947 - Broadmoor  
2690947-01 - Broadmoor  
2691111-00 - Broadmoor

# 44" Mower Deck - Electric Height Adjustment & Roller Bar Group

NOTE: Unless noted otherwise, use the standard hardware torque specification chart.

988349

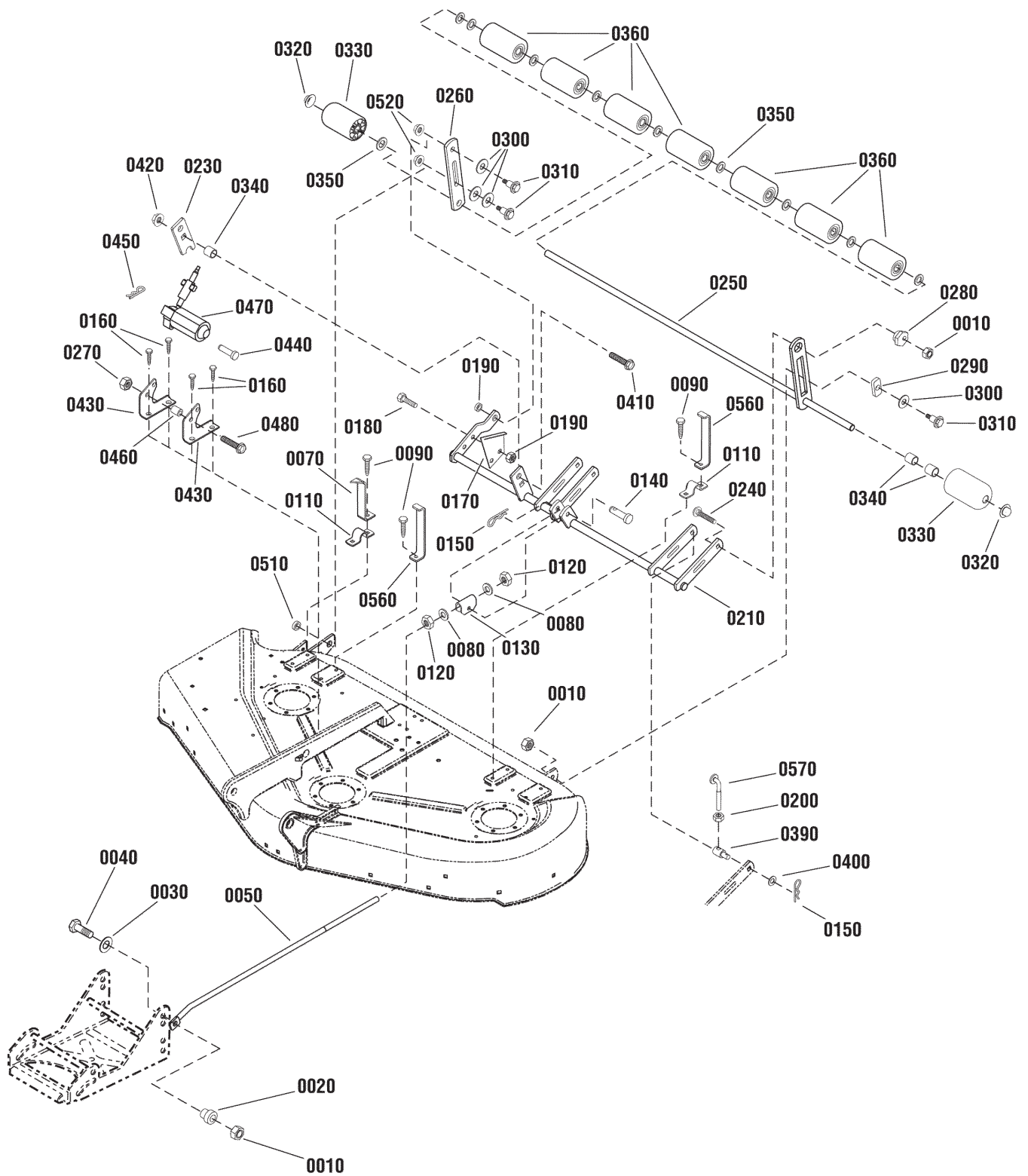

The above parts group applies to the following Mfg. Nos.:

- 1695727 - 44" Mower
- 2690947 - Broadmoor
- 2690947-01 - Broadmoor
- 2691111-00 - Broadmoor

## 44" Mower Deck - Electric Height Adjustment & Roller Bar Group

REF NO	PART NO.	QTY.	DESCRIPTION
0010	2860681	3	LOCKNUT, Security 3/8-16
0020	1706644	1	SPACER
0030	1924940	1	WASHER, 3/8
0040	1922606	1	CAPSCREW, Hex Head, 3/8-16 x 1-3/4
0050	1704093	1	ROD, Adjustment
0070	1720643A	1	INDICATOR, Height
0080	1960170	2	WASHER, 1/2
0090	1664847SM	7	SCREW, Hex Washer Head Taptite 5/16-18 x 3/4
0560	1722748A	1	BRACKET, Up-Stop
0110	1665374BZ	3	STRAP, Roller
0120	1913744	2	NUT, Hex Jam 1/2-13
0130	1704081A	1	TRUNNION, Rod
0140	2118053	1	PIN, Round Head Drilled 3/8 x 2
0150	1960074	2	CLIP, Hair Pin
0160	1930601	4	SCREW, Hex Washer Head Taptite 5/16-18 x 5/8
0170	1704116A	1	BRACKET, Height of Cut
0180	1930591	2	SCREW, Hex Whiz Lock Flange 5/16-18 x 3/4
0190	1931277	2	NUT, Hex Flange 5/16-18 Whiz Lock
0200	1920161	1	NUT, Hex Jam 5/16-18
0210	1733521A	1	SHAFT ASSEMBLY, Rocker 44"
0560	1722747A	1	UP-STOP
0230	1733386A	1	ARM, Rear
0240	1931352	1	CARRIAGE BOLT, 3/8-16 x 1-1/2
0250	1716159A	1	SHAFT & BAR ASSEMBLY, Roller 44"
0260	1704074A	1	BAR, Roller 5/16
0270	1927557	1	NUT, Hex Flange 5/16-18 Whiz Lock
0280	1704082	1	NUT, Hex Adjusting
0290	1677507	1	SLIDE
0300	1924361	4	WASHER, 1/2 x 1-1/2 OD
0310	2172622	3	BOLT, Shoulder 3/8-16
0320	1960520	2	NUT, Push 5/8
0330	1722036	2	ROLLER, Rounded
0340	1602946	3	SPACER
0350	1924366	10	WASHER, 5/8
0360	1668513	7	ROLLER
0570	7028728	1	ROD, Height Adjusting
0390	1731382	1	TRUNNION
0400	1960103	1	WASHER, 3/8
0410	1960706	1	CARRIAGE BOLT, 1/2-13 x 2
0420	1960689	1	NUT, Hex Toplock Flange 1/2-13
0430	1733828A	2	BRACKET, Mounting
0440	1668344	1	PIN, Shear
0450	1960221	1	CLIP, Hairpin

### Footnotes

---

#### The above parts group applies to the following Mfg. Nos.:

1695727 - 44" Mower  
2690947 - Broadmoor  
2690947-01 - Broadmoor  
2691111-00 - Broadmoor

# 44" Mower Deck - Electric Height Adjustment & Roller Bar Group

NOTE: Unless noted otherwise,  
use the standard hardware torque  
specification chart.

988349

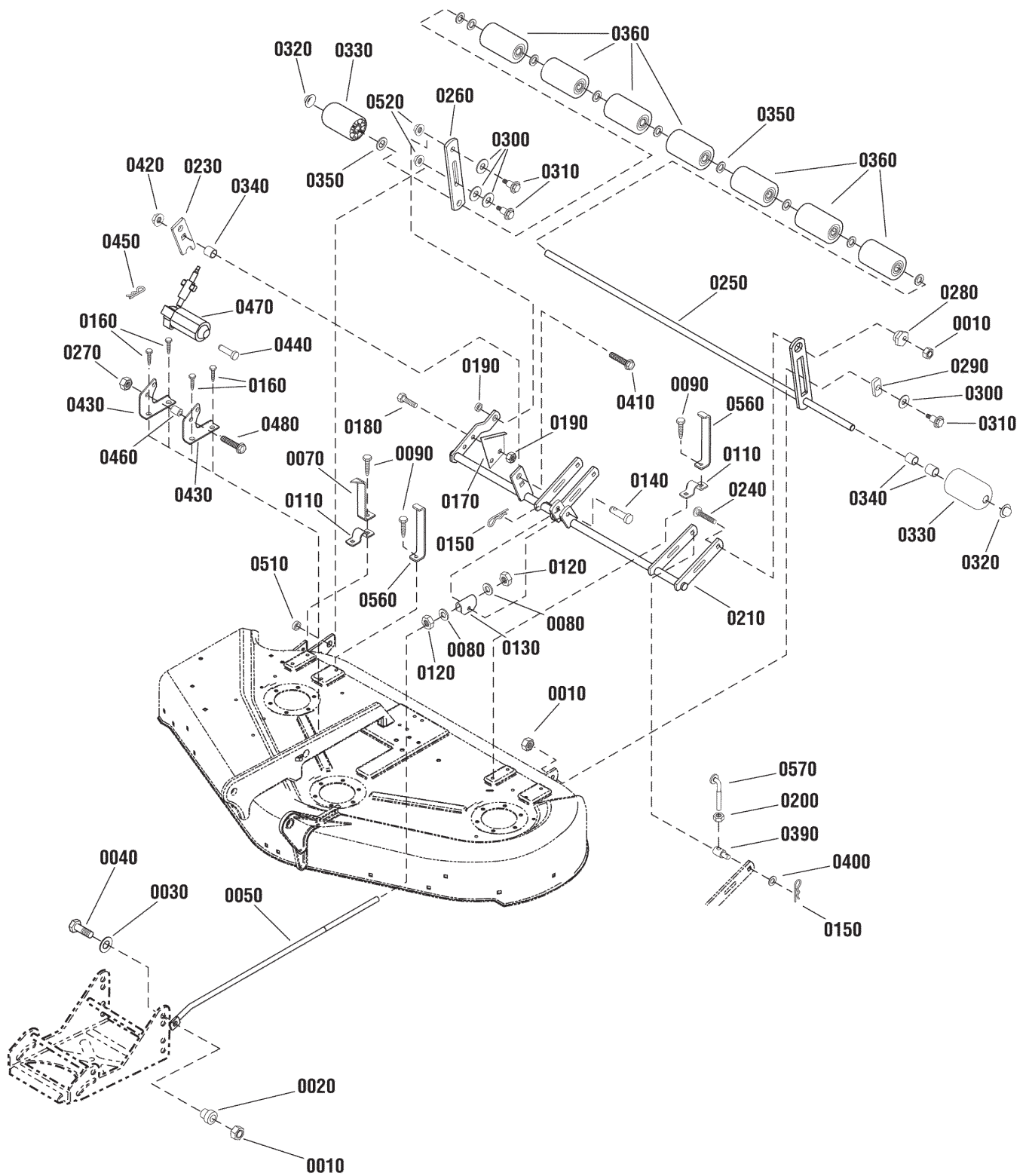

The above parts group applies to the following Mfg. Nos.:

- 1695727 - 44" Mower
- 2690947 - Broadmoor
- 2690947-01 - Broadmoor
- 2691111-00 - Broadmoor

## **44" Mower Deck - Electric Height Adjustment & Roller Bar Group**

---

<b>REF NO</b>	<b>PART NO.</b>	<b>QTY.</b>	<b>DESCRIPTION</b>
0460	1733068	1	SPACER
0470	1733513	1	MOTOR, Electric
0480	1922127	1	CAPSCREW, Hex Head 5/16-18 x 1-3/4
0510	1663752	2	SPACER
0520	1960339	2	NUT, Hex Flange 3/8-16

### **Footnotes**

---

#### **The above parts group applies to the following Mfg. Nos.:**

1695727 - 44" Mower  
2690947 - Broadmoor  
2690947-01 - Broadmoor  
2691111-00 - Broadmoor

# 44" Mower Deck - Housing, Arbors & Blades Group

987515

**NOTE:** Unless noted otherwise, use the standard hardware torque specification chart.

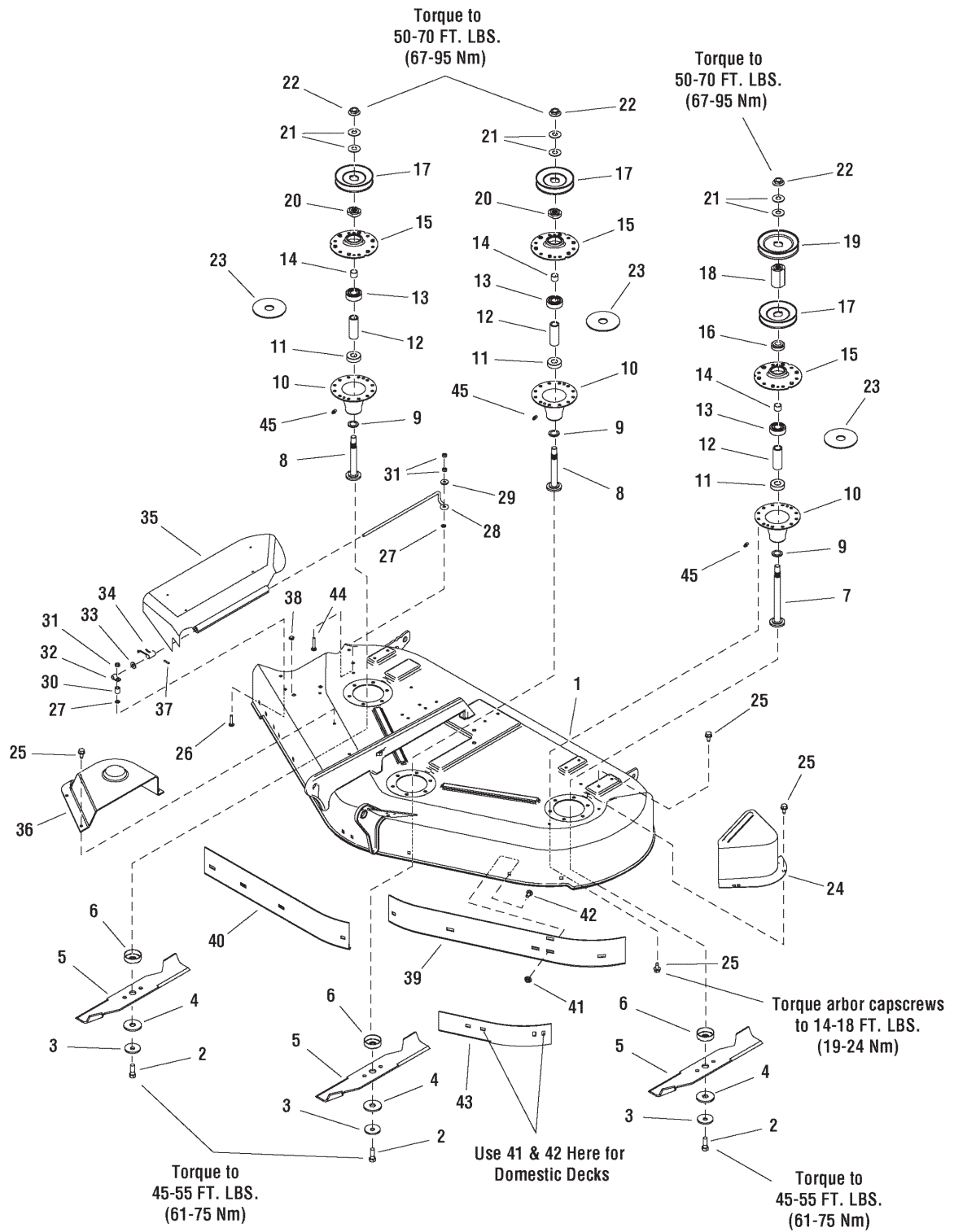

**The above parts group applies to the following Mfg. Nos.:**

- 1695727 - 44" Mower
- 2690947 - Broadmoor
- 2690947-01 - Broadmoor
- 2691111-00 - Broadmoor

## 44" Mower Deck - Housing, Arbors & Blades Group

REF NO	PART NO.	QTY.	DESCRIPTION
1	1687327	1	HOUSING ASSEMBLY, 44"
2	2823471	3	CAPSCREW, Hex Head 7/16-14 x 1-1/4 G8
3	1656916	3	WASHER, Spring
4	1713089	3	WASHER, Hex, 11/16 x 2
5	1727774	3	BLADE, Mower
6	1713196	3	SHIELD, Grass Lower Arbor Heat Treat
7	1713612	1	SHAFT, Arbor
8	1713195	2	SHAFT, Arbor
9	1713619	3	WASHER, Cup
10	1713338A	3	HOUSING, Arbor Bottom w/Lube Fitting (Includes Ref. No. 45)
11	1705897	3	BEARING, Ball 11/16 x 1-9/16 x 15/32
12	1732544	3	SPACER, Powdered Metal
13	2108202	3	BEARING, Ball
14	1715724	3	SPACER, 21/32 x 3/4 x 5/8
15	1655729A	3	HOUSING, Arbor Top
16	1713533	1	HUB, Powdered Metal
17	1713098	3	PULLEY
18	1713158	1	HUB, Hub Serated
19	1732951	1	PULLEY
19	1713091	1	PULLEY (CE/Export)
20	1713197	2	HUB, Pulley, Center & R.H.
21	1713675	6	WASHER, Bellville
22	1714419	3	NUT, Hex Flange 9/16-18
23	1707335	3	GASKET
24	1720560A	1	COVER, Arbor
24	1732200A	1	COVER, Arbor (No Ribs) (CE/Export)
25	1664847SM	27	SCREW, Hex Washer Head Taptite 5/16-18 x 3/4
26	1960633	2	CARRIAGE BOLT, 1/4-20 x 1-1/2 G5
27	1960518	2	NUT, Push for 1/4 Diameter Thread
28	1706709	1	ROD, Deflector
29	1710703	2	SPACER
30	1931320	2	CARRIAGE BOLT, 1/4-20 x 1-1/4 G5
31	1920397	2	NUT, Hex Lock ESNA Light 1/4-20
32	1704873	1	CLAMP, Wire, 5/16 Diameter
33	1919326	1	WASHER, 5/16
34	7101082	1	SPRING, Torsion Chute
35	1705449	1	DEFLECTOR
36	1715673	1	COVER, Arbor
37	1931277	1	NUT, Hex Flange 5/16-18 Whiz Lock Small
38	1705115	1	PLUG, Button
39	1716879A	1	BAFFLE, Blowout 44" LH (CE/Export)
40	1716878A	1	BAFFLE, Blowout 44" RH (CE/Export)
41	1927557	2	NUT, Hex Flange 5/16-18 Whiz Lock Large (Quantity 11 used on CE/Export Models)
42	1921333	2	CAPSCREW, Hex Head 5/16-18 x 1 G5 (Quantity 11 used on CE/Export Models)

### Footnotes

#### The above parts group applies to the following Mfg. Nos.:

1695727 - 44" Mower  
 2690947 - Broadmoor  
 2690947-01 - Broadmoor  
 2691111-00 - Broadmoor

# 44" Mower Deck - Housing, Arbors & Blades Group

987515

**NOTE:** Unless noted otherwise, use the standard hardware torque specification chart.

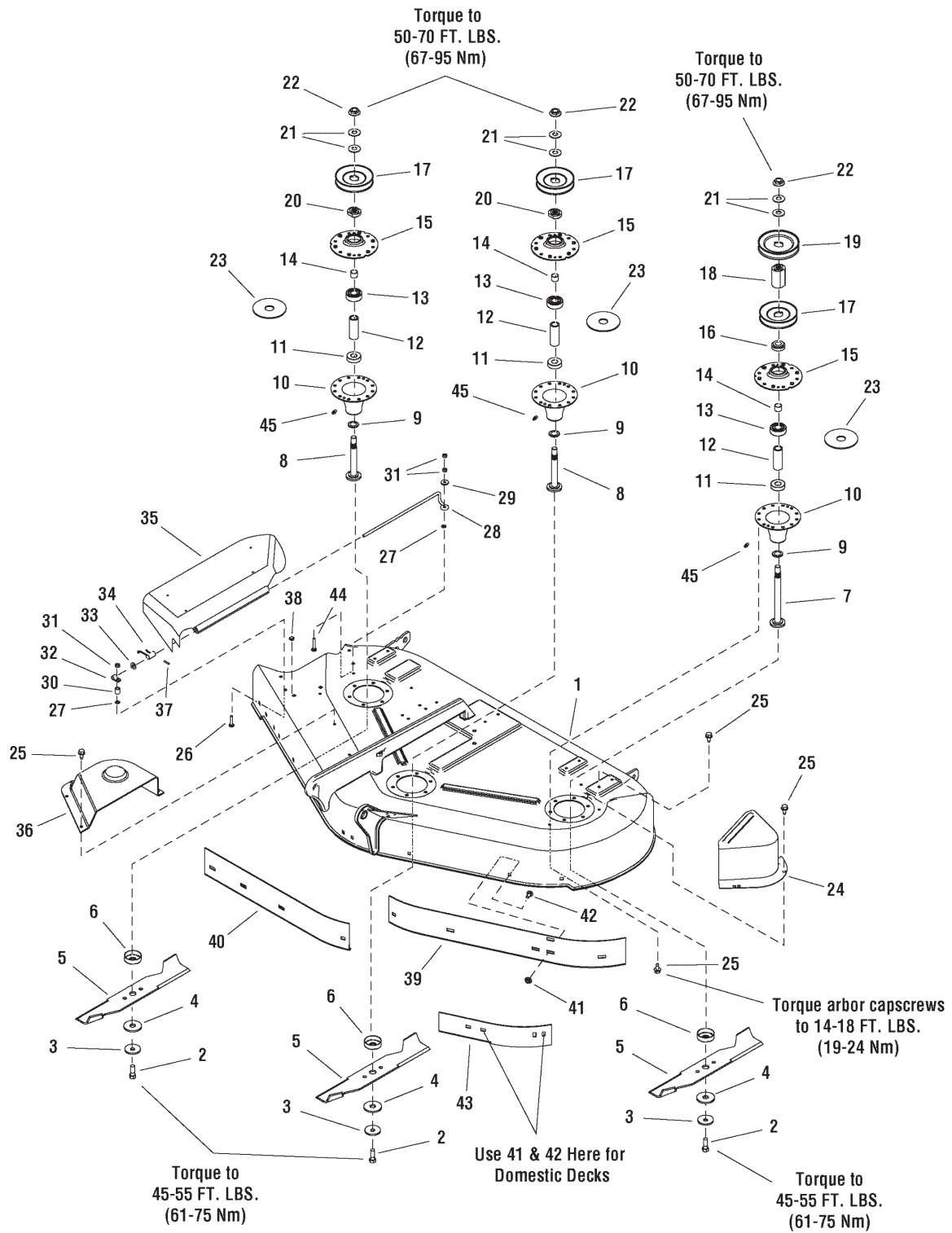

**The above parts group applies to the following Mfg. Nos.:**

- 1695727 - 44" Mower
- 2690947 - Broadmoor
- 2690947-01 - Broadmoor
- 2691111-00 - Broadmoor



## **44" Mower Deck - Housing, Arbors & Blades Group**

---

<b>REF NO</b>	<b>PART NO.</b>	<b>QTY.</b>	<b>DESCRIPTION</b>
43	1724538A	1	BAFFLE, Short Blowout
44	1960633	1	CARRIAGE BOLT, 1/4-20 x 1-1/2
45	1704314	3	FITTING, Grease 1/4 Drive

---

### **Footnotes**

---

#### **The above parts group applies to the following Mfg. Nos.:**

1695727 - 44" Mower  
2690947 - Broadmoor  
2690947-01 - Broadmoor  
2691111-00 - Broadmoor

# 46" & 52" Mower Deck - Clutch & Support Group

NOTE: Unless noted otherwise,  
use the standard hardware torque  
specification chart.

988066\_988067\_988329

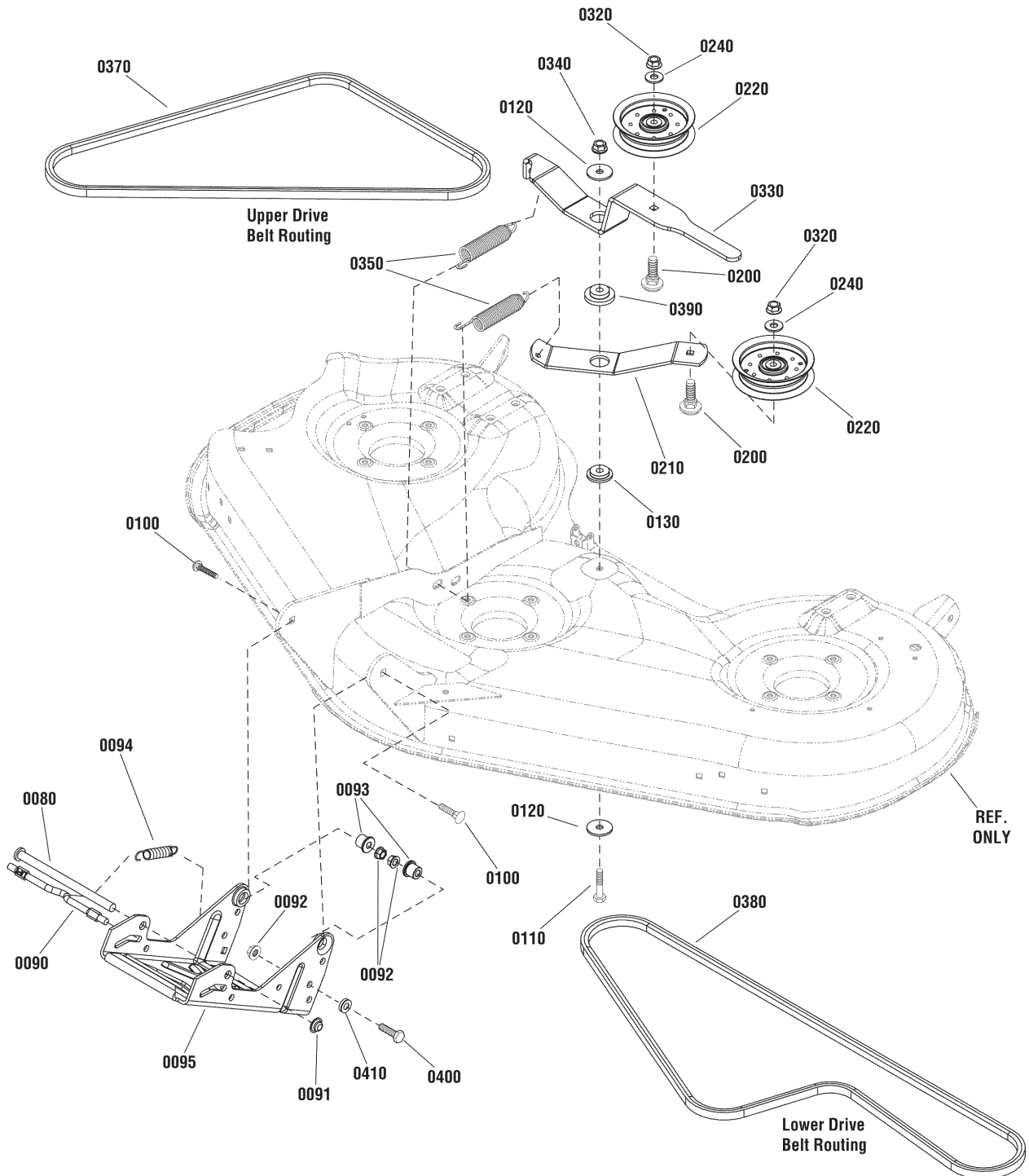

The above parts group applies to the following Mfg. Nos.:

- 1695551 - 46" Mower
- 1695768 - 52" Mower
- 2690948 - Broadmoor
- 2690949 - Broadmoor

## 46" & 52" Mower Deck - Clutch & Support Group

REF NO	PART NO.	QTY.	DESCRIPTION
0080	1713578	1	ROD, 1/2 Dia. x 7-5/8
0090	1715759	1	ROD, 3/8 Dia. x 8
0091	1960519	1	PUSHNUT, 1/2
0092	1960687	3	NUT, Hex Flange, 3/8-16
0093	1732443	2	SPACER, 3/4 OD x 3/4 Long
0094	2156302	1	SPRING, Extension, 4-1/8
0095	1738040A	1	HITCH, Mower
0100	7091945	2	BOLT, Carriage, , 3/8C X1-1/2 GR5 YZ
0110	1921971	1	CAPSCREW, Hex Head, 3/8-16 x 1-3/4, G5
0120	1924356	2	WASHER, 3/8, 1/2 OD
0130	1714255	1	SPACER, 1-1/2 OD
0200	7091158	2	USE - 91810 BOLT, Carriage, 3/8C X1-3/4, G5
0210	1735321A	1	ARM, Idler, Lower
0220	1736540	2	PULLEY, Idler, 46 & 52" Mowers
0240	7091528	2	WASHER, Flat, 3/8 x .875
0320	7091619	2	NUT, Whiz, 3/8
0330	1739585A	1	ARM, Idler, Upper
0340	1930645	1	NUT, Hex Flange, Two Way Locking, 3/8-16
0350	1715772	2	SPRING, Extension, 5-1/4
0370	1752103YP	1	V-BELT, HA, 63.10 (46" Decks Only)
0370	2101137	1	V-BELT, HA, 68.10 (52" Decks Only)
0380	1666801	1	V-BELT, HA, 87.20 (46" Decks Only)
0380	1665450	1	V-BELT, HA, 87.20 (52" Decks Only)
0390	1739594	1	SPACER, 1-3/4 OD
0400	5025013X8	1	BOLT, 3/8-16 x 1, G5
0410	5044960	1	SPACER, 3/8 x 1 x 1/4

### Footnotes

---

#### The above parts group applies to the following Mfg. Nos.:

1695551 - 46" Mower  
1695768 - 52" Mower  
2690948 - Broadmoor  
2690949 - Broadmoor

# 46" & 52" Mower Deck - Height Adjustment & Roller Bar Group

988330\_988332

**NOTE:** Unless noted otherwise,  
use the standard hardware torque  
specification chart.

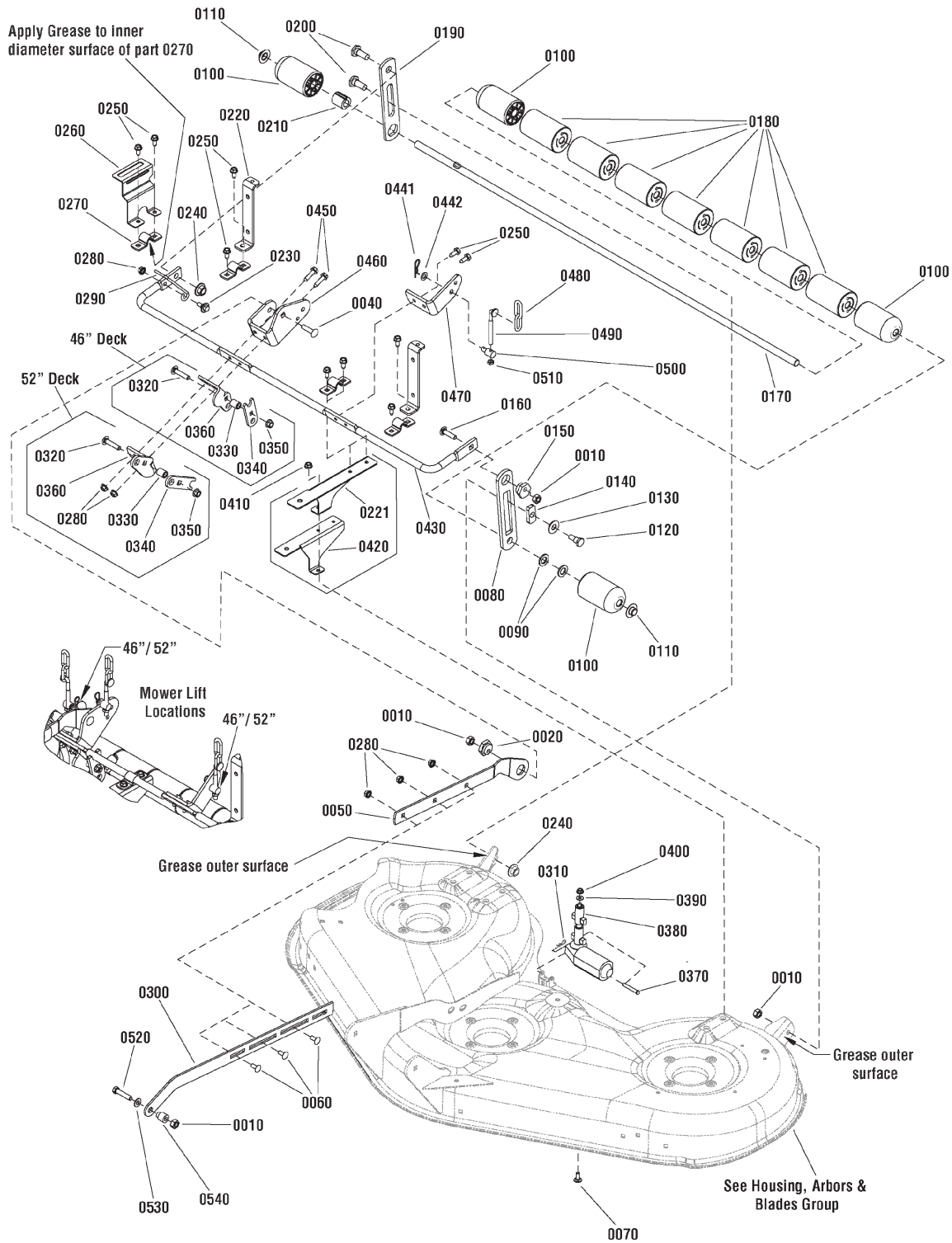

**The above parts group applies to the following Mfg. Nos.:**

- 1695551 - 46" Mower
- 1695768 - 52" Mower
- 2690948 - Broadmoor
- 2690949 - Broadmoor

## 46" & 52" Mower Deck - Height Adjustment & Roller Bar Group

REF NO	PART NO.	QTY.	DESCRIPTION
0010	2860681	4	NUT, Hex, Top Lock, Spiral Flange, 3/8-16
0020	1727381	1	NUT, Hex Adjusting, 1 Dia
0040	1960268	1	BOLT, Carriage, 3/8-16 x 1-1/4, G5
0050	1739691A	1	ARM, Pitch Adjustment, Front
0060	7090001	3	BOLT, Carriage, 5/16 x 3/4, G5
0070	1931333	1	BOLT, Carriage, 5/16-18 x 3/4, G5
0080	1704073A	1	BAR, Roller
0090	1960035	2	WASHER, 5/8 x 1-3/4 (46" Decks Only)
0090	1924366	2	WASHER, 5/8 x 1-1/8 (52" Decks Only)
0100	1722036	4	ROLLER, 2-1/2 OD
0110	1960520	2	PUSHNUT, 5/8, Capped
0120	2172622	1	BOLT, Shoulder, 3/8-16 x 1-11/32, G5
0130	1924361	1	WASHER, 1/2 x 1-1/4
0140	1677507	1	SLIDE
0150	1704082	1	NUT, Hex Adjusting, .990DIA
0160	7091945	1	BOLT, Carriage, 3/8 x 1-1/2, G5
0170	1736155	1	SHAFT-ROLLER, 39-5/8 Long (46" Decks Only)
0170	1736154	1	SHAFT-ROLLER, 47-29/32 Long (52" Decks Only)
0180	1668513	7	ROLLER, 2-1/2 OD x 4-3/32 Long
0190	1735327A	1	BAR, Roller
0200	1737409	2	BOLT, Shoulder, 2-9/16 Long
0221	1734806A	2	SUPPORT, Rocker Shaft (46" Decks Only)
0210	1736152	1	SPACER, Roller (52" Decks Only)
0220	1737219BM	2	UPSTOP, Rear
0230	720107	1	BOLT, Shoulder, 5/16-18 x 1/4
0240	1930644	2	NUT, Hex Flange, Two Way Locking, 1/2-13
0250	1664847SM	10	SCREW, Hex Washer Head, Taptite, 5/16-18 x 3/4
0260	1736850A	1	BRACKET, Height of Cut
0270	1736156A	4	STRAP, Rocker Shaft
0280	720139	6	NUT, Hex Flange, 5/16-18
0290	1736851	1	ROD, Height of Cut Indicator
0300	1739554A	1	ARM, Pitch Adjustment
0310	1960221	1	CLIP, Hairpin 5/8 Dia. x 1-5/16
0320	7091810	1	BOLT, Carriage, 3/8 x 1-3/4, G5
0330	7014334	1	SPACER, 5/8 OD x 3/8 ID
0340	1736956A	1	ARM MOUNT, 5/8 (46" Decks Only)
0340	1739459A	1	ARM, MOUNT, 5/8 (52" Decks Only)
0350	7091619	1	HFLN, 3/8C YZ
0360	1736952A	1	ARM MOUNT, EHOC (46" Decks Only)
0360	1739458A	1	ARM, MOUNT, EHOC (52" Decks Only)
0370	1668344	1	PIN, Shear, 1/4 ID. X 1-3/4
0380	1733513	1	MOTOR, Electric
0390	1921319	1	WASHER, 1/4 x 5/8 OD
0400	1960757	1	NUT, Hex, 1/4-20, L.H. Thread

### Footnotes

---

#### The above parts group applies to the following Mfg. Nos.:

1695551 - 46" Mower  
1695768 - 52" Mower  
2690948 - Broadmoor  
2690949 - Broadmoor

# 46" & 52" Mower Deck - Height Adjustment & Roller Bar Group

988330\_988332

**NOTE:** Unless noted otherwise,  
use the standard hardware torque  
specification chart.

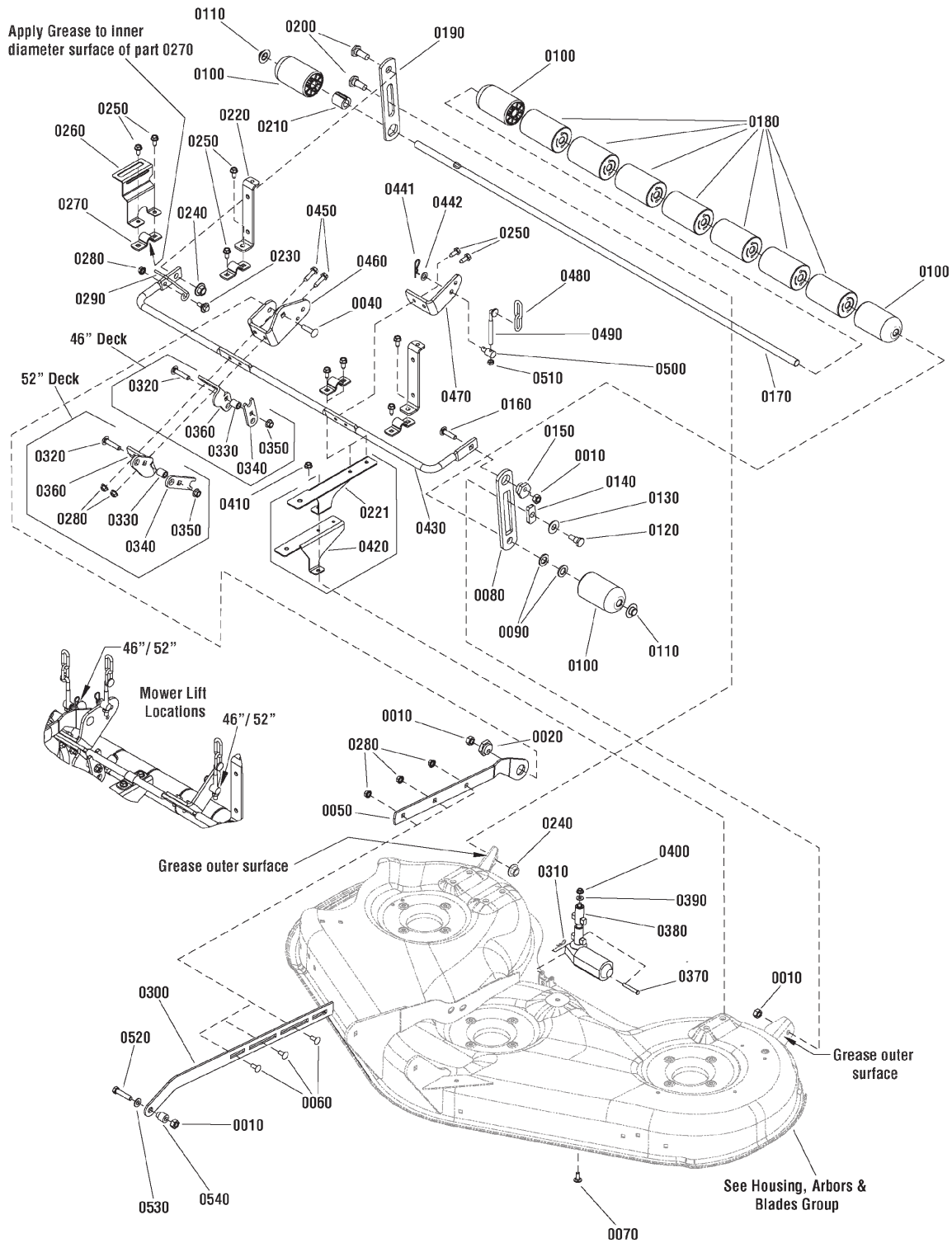

**The above parts group applies to the following Mfg. Nos.:**

- 1695551 - 46" Mower
- 1695768 - 52" Mower
- 2690948 - Broadmoor
- 2690949 - Broadmoor

## **46" & 52" Mower Deck - Height Adjustment & Roller Bar Group**

<b>REF NO</b>	<b>PART NO.</b>	<b>QTY.</b>	<b>DESCRIPTION</b>
0410	1931277	1	NUT, Hex Flange, 5/16-18
0420	1737011A	1	SUPPORT, Rocker Shaft (52" Decks Only)
0430	1736563	1	SHAFT, Rocker
0441	1960074	2	CLIP, Hair Pin 15/16 Dia. x 5/8 Long
0442	1960103	2	WASHER, 3/8 x 3/4 OD
0450	1931202	2	CAPSCREW, Hex Washer Head, Taptite, 5/16-18 x 1-1/4
0460	1739557A	1	ARM, Mower Lift, R.H.
0470	1736108A	1	ARM, Mower Lift, L.H.
0480	1731383	2	CHAIN, Link, 2.8 Long
0490	7028728	2	ROD, Height Adjust, Chain, 3.68" (Long)
0500	1731382	2	TRUNNION, 5/8 OD x 1-11/32 Long
0510	7091493	2	NUT, Hex Jam, 5/16
0520	1921971	1	CAPSCREW, Hex Head, 3/8-16 x 1-3/4, G5
0530	5025156	1	WASHER, 3/8
0540	1706644	1	SPACER, 3/8 x 3/4 x 15/16
0550	5021030	1	CABLE TIE, 6

### **Footnotes**

---

#### **The above parts group applies to the following Mfg. Nos.:**

1695551 - 46" Mower  
1695768 - 52" Mower  
2690948 - Broadmoor  
2690949 - Broadmoor

# 46" & 52" Mower Deck - Housing, Arbors & Blades Group

988057\_988061

NOTE: Unless noted otherwise, use the standard hardware torque specification chart.

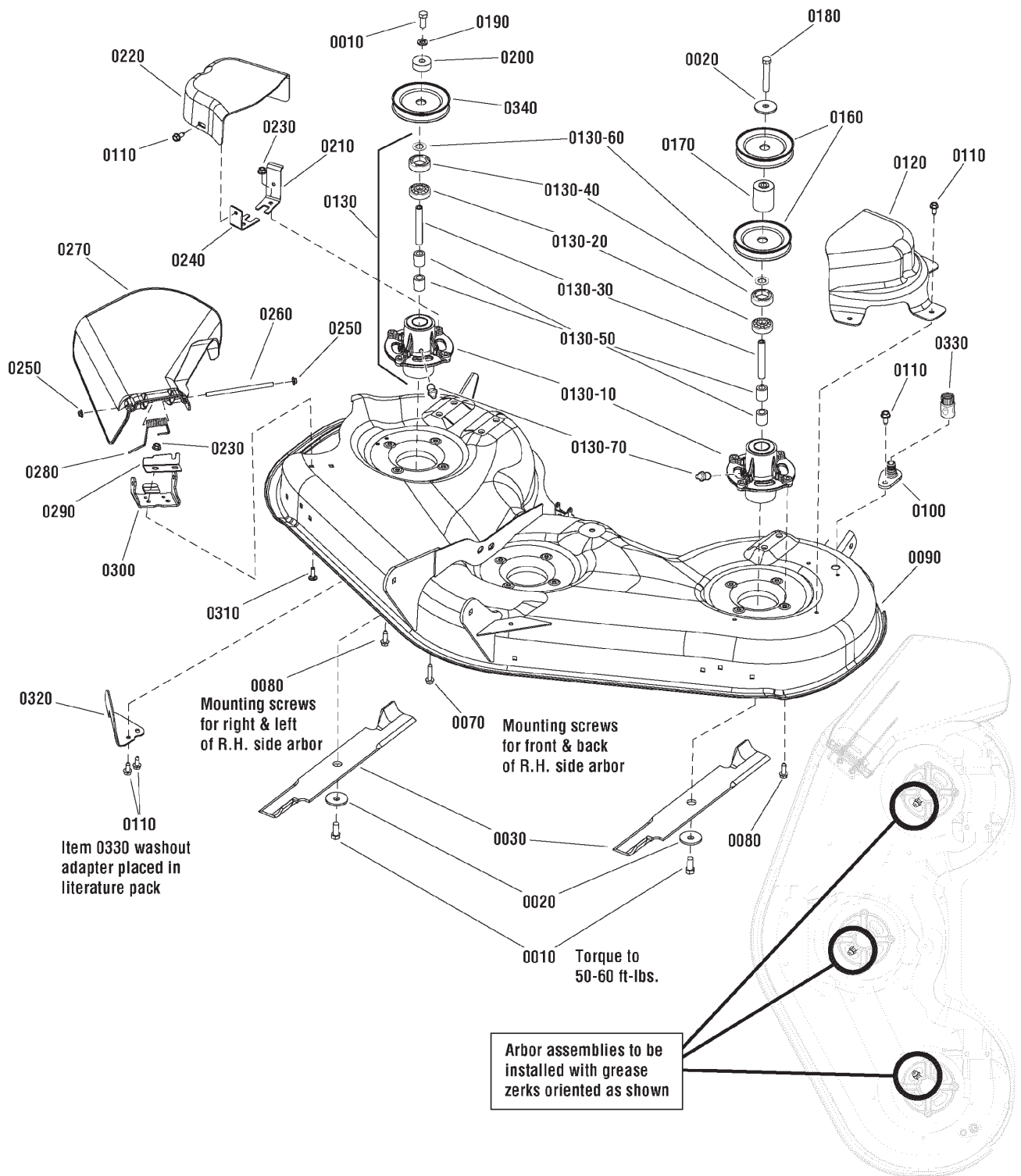

The above parts group applies to the following Mfg. Nos.:

- 1695551 - 46" Mower
- 1695768 - 52" Mower
- 2690948 - Broadmoor
- 2690949 - Broadmoor



## 46" & 52" Mower Deck - Housing, Arbors & Blades Group

REF NO	PART NO.	QTY.	DESCRIPTION
0010	1920676	5	CAPSCREW, Hex Head, 7/16-14 x 1, G5
0020	1656916	4	WASHER, Spring, 1-3/4 OD
0030	1737228A	3	BLADE, Mower, 18-1/2 Long (46" Decks Only)
0030	1737252A	3	BLADE, Mower, 18-1/2 Long (52" Decks Only)
0070	1930600	2	CAPSCREW, Hex Washer Head, Taptite, 5/16-18 x 1-1/2
0080	1960373	10	CAPSCREW, Hex Washer Head, Taptite, 5/16-18 x 1
0090	1735709C	1	HOUSING ASSEMBLY, Orange (46" Decks Only)
0090	1739584C	1	HOUSING ASSEMBLY, Orange (52" Decks Only - Domestic)
0090	1751883C	1	HOUSING ASSEMBLY, Orange (52" Decks Only - Export)
0090	1735709D	1	HOUSING ASSEMBLY, Red (46" Decks Only)
0090	1739584D	1	HOUSING ASSEMBLY, Red (52" Decks Only)
0100	1735716	1	ADAPTER, Washout
0110	1664847SM	8	CAPSCREW, Hex Washer Head, Taptite, 5/16-18 x 3/4
0120	1735750	1	COVER, Belt, L.H. (46" Decks Only)
0120	1736505	1	COVER, Belt, L.H. (52" Decks Only - Domestic)
0130	5405811	3	SPINDLE ASSEMBLY
0130-10	1737352	1	HOUSING, Spindle
0130-20	1735399	2	BEARING, Ball, 20mm
0130-30	1735326	1	SHAFT, Spindle
0130-40	1735323	2	SHIELD, Arbor, 2-1/16 OD
0130-50	1735328	2	SPACER, Bearing
0130-60	1960766	2	RING, Self Locking
0130-70	1704314	3	FITTING, Lubrication
0160	1735733	1	PULLEY, 5-1/2 OD (52" Decks Only)
0170	1739567	1	SPACER, Pulley, 46" Mower
0180	1926110	1	CAPSCREW, Hex Head, 7/16-14 x 2-3/4, G5
0190	1918199	2	LOCKWSHER, Spring, 7/16
0200	1735579	2	SPACER, Lower Drive (46" Decks Only)
0210	1736519BM	1	BRACKET, Belt, Cover, Rear
0220	1735752	1	COVER, Belt, R.H. (46" & 52" Decks)
0230	1931277	4	NUT, Whix Lock, 5/16-18
0240	1736518BM	1	BRACKET, Belt, Cover, Front
0250	7012542	2	PUSHNUT, 5/16
0260	1736366	1	ROD, Deflector
0270	1735447	1	DEFLECTOR, Discharge
0280	1736364	1	SPRING, Deflector, 2-5/32 Long (46" Decks Only)
0290	1737359BM	1	PLATE, Deflector, Close Off
0300	1736365A	1	HINGE, Deflector (46" Decks Only)
0300	1737418BM	1	HINGE, Deflector (52" Decks Only)
0310	1931333	2	BOLT, Carriage, 5/16-18 x 7/8, G5 (46" Decks Only)
0310	1931334	2	BOLT, Carriage, 5/16-18 x 7/8, G5 (52" Decks Only)
0320	1737279BM	1	BAFFLE
0330	1736898	1	WASHOUT PORT, Connector
0340	1735686	3	PULLEY, 4-5/8 OD (46" Decks Only)

### Footnotes

---

#### The above parts group applies to the following Mfg. Nos.:

1695551 - 46" Mower  
1695768 - 52" Mower  
2690948 - Broadmoor  
2690949 - Broadmoor

# 50" Mower Deck - Clutch & Support Group

2984271

**NOTE:** Unless noted otherwise,  
use the standard hardware torque  
specification chart.

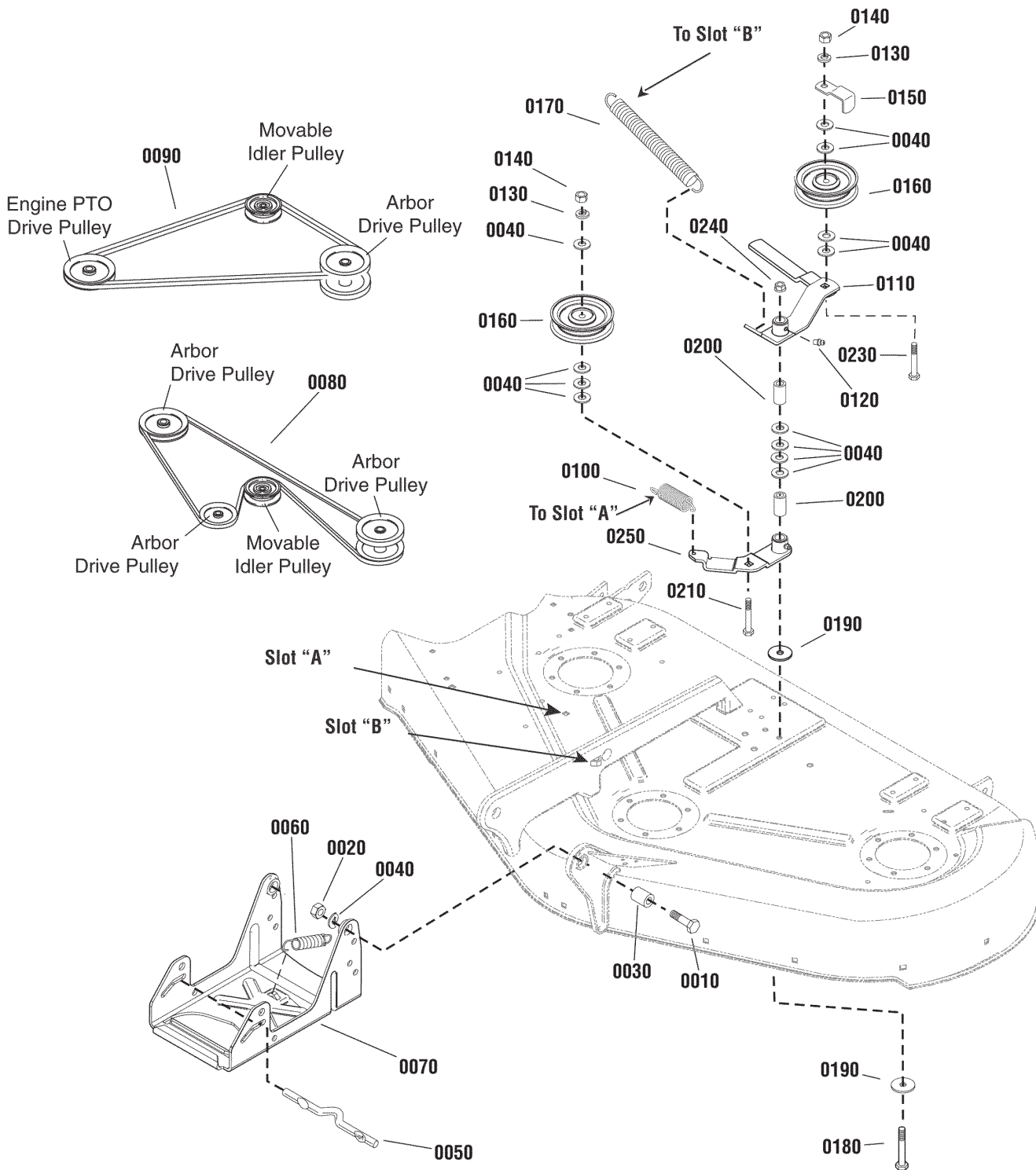

**The above parts group applies to the following Mfg. Nos.:**

2691112-00 - Broadmoor

## 50" Mower Deck - Clutch & Support Group

REF NO	PART NO.	QTY.	DESCRIPTION
0090	1707740	1	V-BELT, Mower Drive
0080	1703836	1	V-BELT, Arbor Drive
0240	1960339	1	NUT, Hex, 3/8-16
0130	1916965	2	WASHER, Lock, 3/8
0150	1677135A	1	BELT STOP, Idler
0040	1924940	14	WASHER, 3/8
0160	1724387	2	PULLEY, Idler
0140	1916950	2	NUT, Hex Flange, 3/8-16, MAC Lock Large, Black
0170	1715435	1	SPRING
0200	1674669	2	SPACER, 25/64 x 5/8 x 1-1/8, Case Hardened
0120	2812808	1	GREASE FITTING
0110	1704658	1	LEVER ASSEMBLY, Idler
0230	1960315	1	CARRIAGE BOLT, 3/8-16 x 2
0250	1718561	1	LEVER ASSEMBLY, Idler Arm
0190	1924356	2	WASHER, 3/8, Black
0210	1931352	1	CARRIAGE BOLT, 3/8-16 x 1-1/2
0100	1656936	1	SPRING
0180	1923938	1	CAPSCREW, Hex Head, 3/8-16 x 3-1/2
0010	1921968	2	CAPSCREW, Hex Head, 3/8-16 x 1-3/8
0030	2157081	2	SPACER, 3/8 x 3/4 x 1/2
0020	2860681	2	NUT, Hex Toplock Spirallock Flange, 3/8-16
0060	2156302	1	SPRING
0070	1707432A	1	HITCH ASSEMBLY
0050	1715759	1	ROD, Latch

### Footnotes

---

The above parts group applies to the following Mfg. Nos.:

2691112-00 - Broadmoor

# 50" Mower Deck - Electric Height Adjustment & Roller Group

987880

NOTE: Unless noted otherwise,  
use the standard hardware torque  
specification chart.

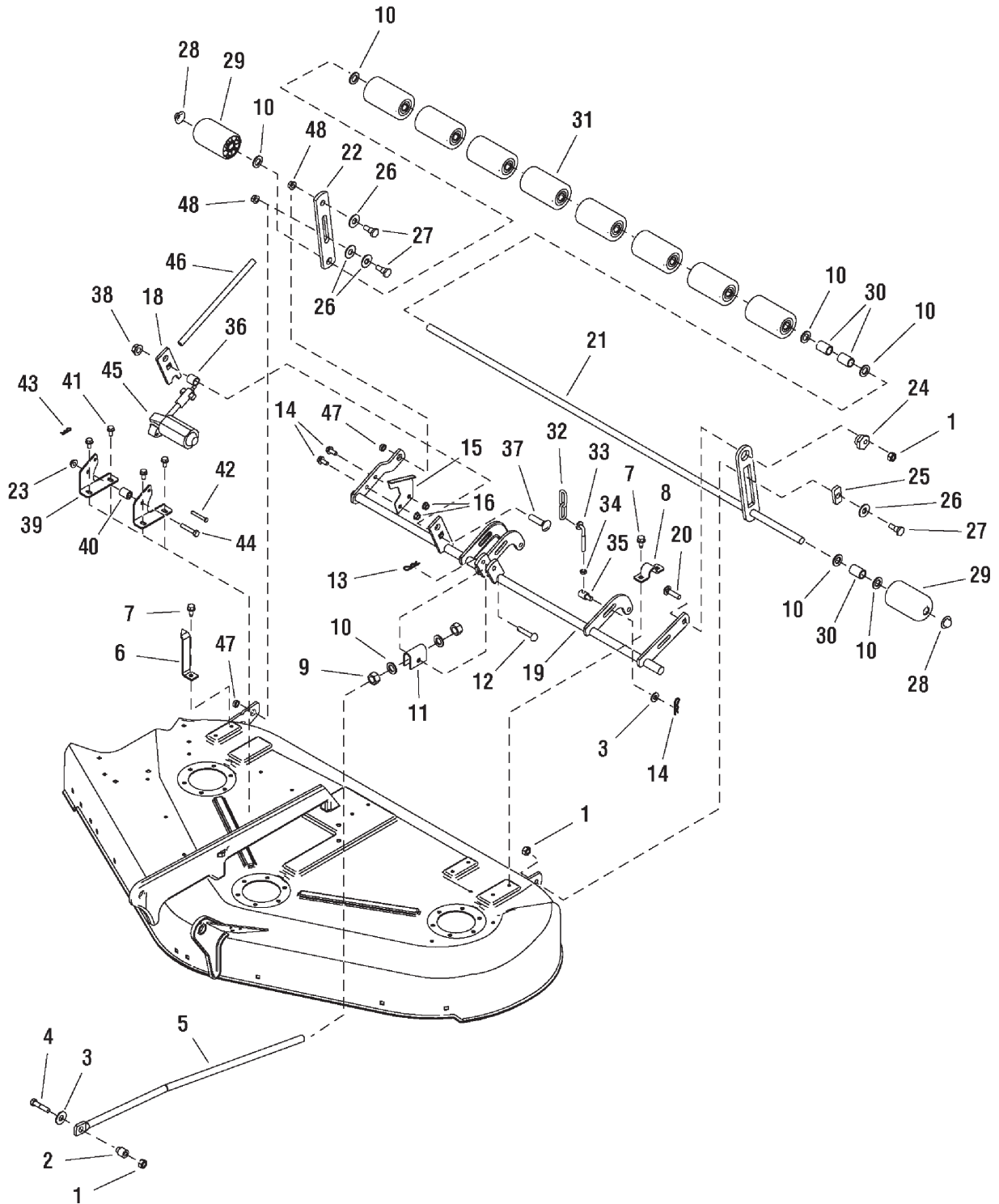

The above parts group applies to the following Mfg. Nos.:

2691112-00 - Broadmoor

## 50" Mower Deck - Electric Height Adjustment & Roller Group

REF NO	PART NO.	QTY.	DESCRIPTION
1	2860681SM	3	NUT, Hex TopLock Spiral Lock Flange 3/8-16
2	1706644SM	1	SPACER, 3/8 x 3/4 x 15/17
3	1924940SM	3	WASHER, 3/8
4	1922606SM	1	CAPSCREW, Hex Head 3/8-16 x 1-3/4 G8
5	1722995SM	1	ROD, Adjusting
6	1720643ASM	1	INDICATOR, Height
7	1664847SM	6	SCREW, Hex Washer Head Taptite 5/16-18 x 3/4
8	1665374SM	3	STRAP
9	1915726SM	2	NUT, Hex 5/8-11
10	1924366SM	8	WASHER, 5/8
11	1706645ASM	1	TRUNNION
12	2118053SM	1	PIN, Round Head Drilled 3/8 x 2
13	1960074SM	3	CLIP, Hair Pin
14	1930591SM	2	SCREW, Hex Whiz Lock Flange 5/16-18 x 3/4
15	1704116ASM	1	BRACKET, Height of Cut 16GA
16	1931277SM	2	NUT, Hex Flange 5/16-18 Whiz Lock Small
18	1733386ASM	1	ARM, Rear
19	1733522ASM	1	SHAFT ASSEMBLY, Rocker 50"
20	1931352SM	1	CARRIAGE BOLT, 3/8-16 x 1-1/2 G5
21	1716155ASM	1	SHAFT & BAR ASSEMBLY, Roller
22	1704074ASM	1	BAR, Roller
23	1927557SM	1	NUT, Hex Flange 5/16-18 Whiz Lock Large
24	1704082SM	1	NUT, Hex Adjusting
25	1677507SM	1	SLIDE
26	1924361SM	4	WASHER, 1/2
27	2172622SM	3	BOLT, Shoulder 3/8-16 G5
28	1960520SM	2	NUT, Push for 5/8 Diameter Stud Capped
29	1722036SM	2	ROLLER
30	1709195SM	3	SPACER
31	1668513SM	8	ROLLER
32	1731383ASM	2	CHAIN, Link
33	1731384SM	2	ROD, Height Adjusting
34	1920161SM	2	NUT, Hex Jam 5/16-18
35	1731382SM	2	TRUNNION
36	1602946SM	1	SPACER
37	1960706SM	1	CARRIAGE BOLT, 1/2-13 x 2 G5
38	1960689SM	1	NUT, Hex Toplock Flange 1/2-13
39	1733828ASM	2	BRACKET, Mounting
40	1733068SM	1	SPACER
41	1930601SM	4	SCREW, Hex Washer Head Taptite 5/16-18 x 5/8
42	1668344SM	1	PIN, Shear
43	1960221SM	1	CLIP, Hairpin
44	1922127SM	1	CAPSCREW, Hex Head 5/16-18 x 1-3/4 G5
45	1733513SM	1	MOTOR, Electric

### Footnotes

The above parts group applies to the following Mfg. Nos.:

2691112-00 - Broadmoor

# 50" Mower Deck - Electric Height Adjustment & Roller Group

987880

NOTE: Unless noted otherwise,  
use the standard hardware torque  
specification chart.

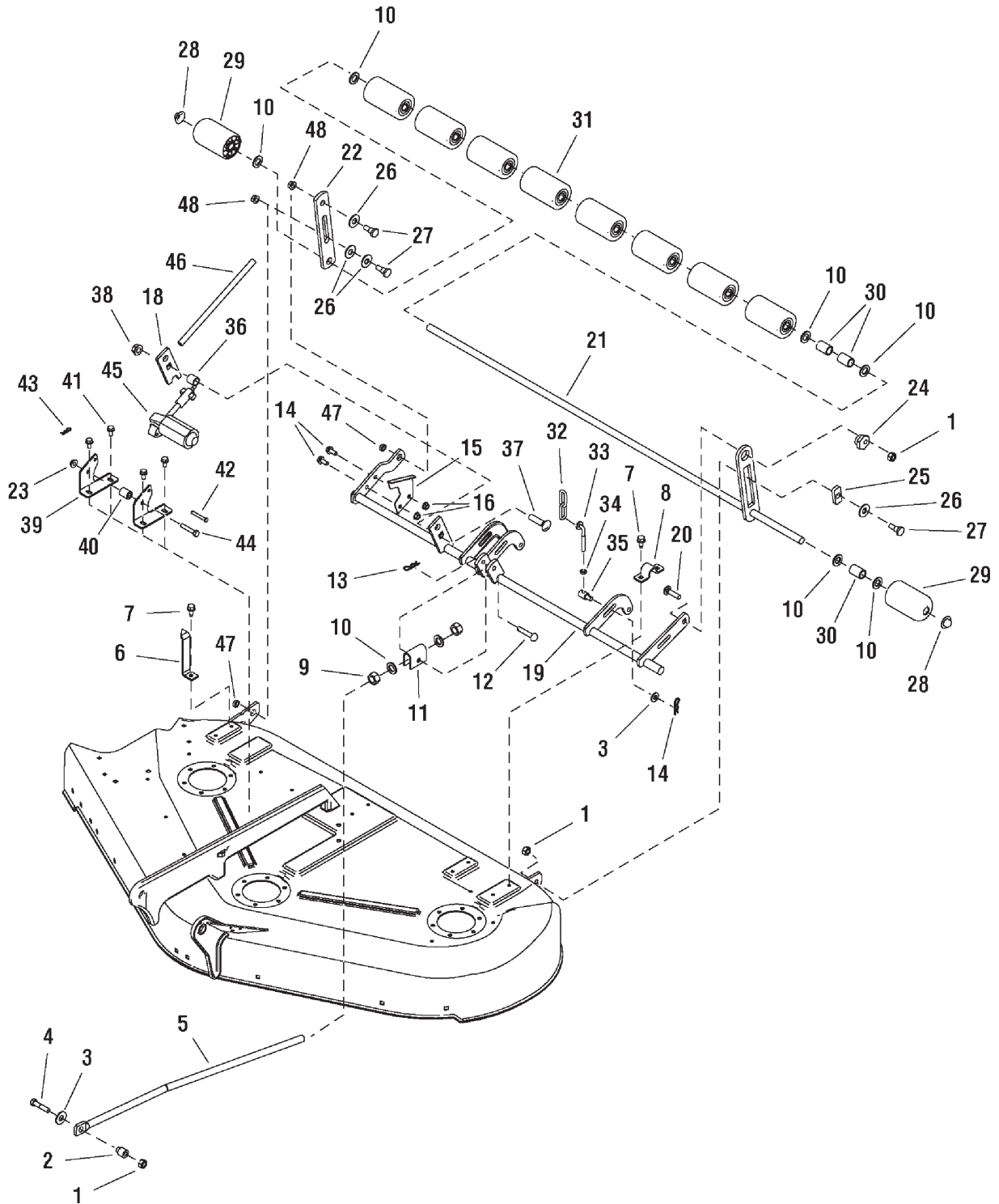

The above parts group applies to the following Mfg. Nos.:

2691112-00 - Broadmoor

## **50" Mower Deck - Electric Height Adjustment & Roller Group**

---

<b>REF NO</b>	<b>PART NO.</b>	<b>QTY.</b>	<b>DESCRIPTION</b>
46	1733895SM	1	TUBE
47	1663752SM	2	SPACER
48	1960339SM	2	NUT, Hex Flange 3/8-16 Machine Lock Large

---

### **Footnotes**

---

**The above parts group applies to the following Mfg. Nos.:**

2691112-00 - Broadmoor

# 50" Mower Deck - Housing, Arbors & Blades Group

2987520

**NOTE:** Unless noted otherwise, use the standard hardware torque specification chart.

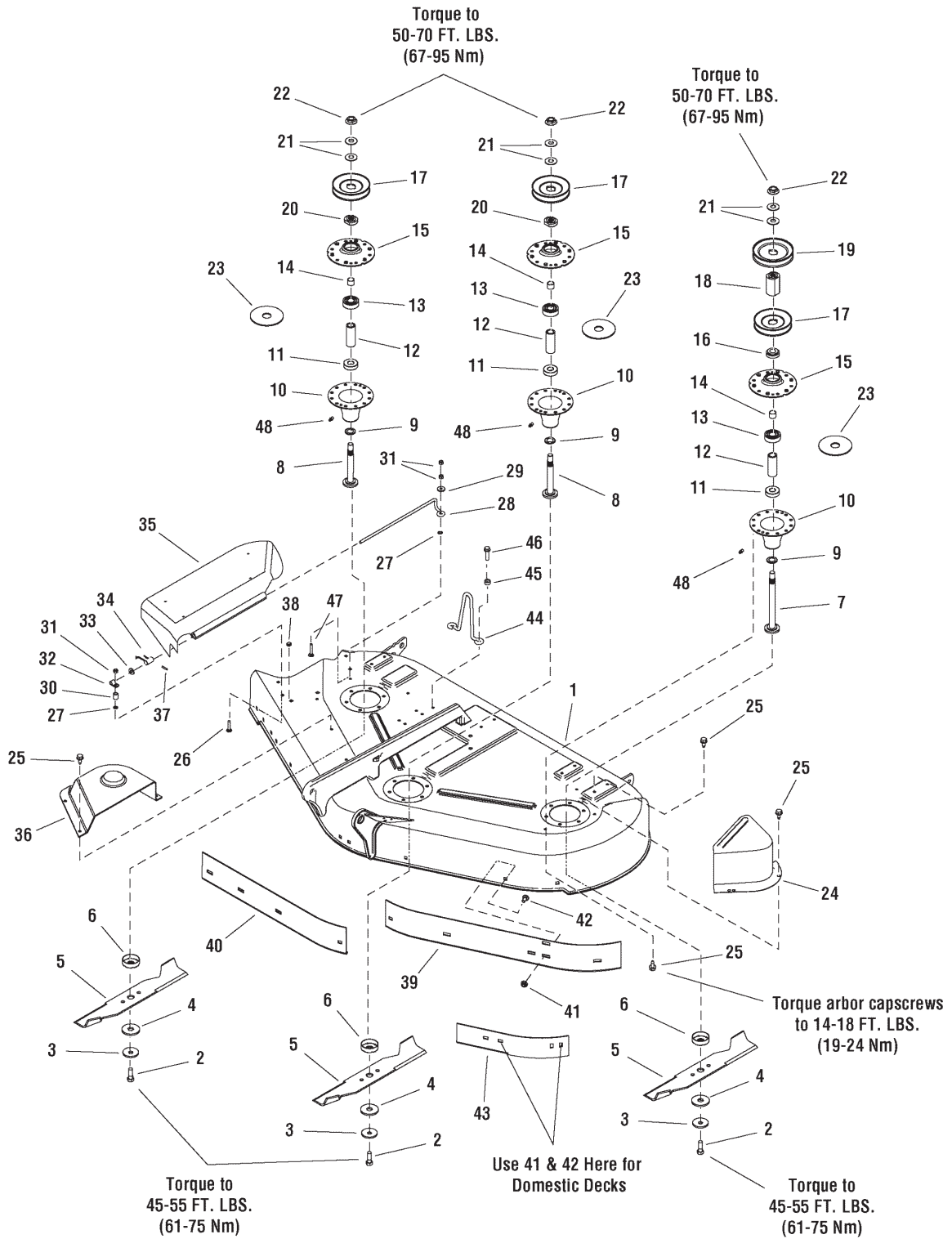

**The above parts group applies to the following Mfg. Nos.:**

2691112-00 - Broadmoor



## 50" Mower Deck - Housing, Arbors & Blades Group

REF NO	PART NO.	QTY.	DESCRIPTION
1	1687325	1	HOUSING ASSEMBLY, 50" (Orange)
2	2823471	3	CAPSCREW, Hex Head 7/16-14 x 1-1/4 G8
3	1656916	3	WASHER, Spring
4	1713089	3	WASHER, Hex, 11/16 x 2
5	1726453A	3	BLADE, Mower 50"
6	1713196	3	SHIELD, Grass Lower Arbor Heat Treat
7	1713612	1	SHAFT, Arbor
8	1713195	2	SHAFT, Arbor
9	1713619	3	WASHER, Cup
10	1713338A	3	HOUSING, Arbor Bottom w/Lube Fitting (Includes Ref. No. 48)
11	1705897	3	BEARING, Ball, 11/16 x 1-9/16 x 15/32
12	1732544	3	SPACER, Powdered Metal
13	2108202	3	BEARING, Ball
14	1715724	3	SPACER, 21/32 x 3/4 x 5/8
15	1655729A	3	HOUSING, Arbor Top
16	1713533	1	HUB, Powdered Metal
17	1713098	3	PULLEY
18	1713158	1	HUB, Serated Powdered Metal
19	1732951	1	PULLEY
20	1713197	2	HUB, Pulley, Center & R.H.
21	1713675	6	WASHER, Bellville
22	1714419	3	NUT, Hex Flange 9/16-18
23	1707335	3	GASKET, Foam Poly
24	1720560A	1	COVER, Arbor
25	1664847SM	27	SCREW, Hex Washer Head Taptite 5/16-18 x 3/4
26	1931320	2	CARRIAGE BOLT, 1/4-20 x 1-1/4 G5
27	1960518	2	NUT, Push for 1/4 Diameter Thread
28	1706709	1	ROD, Deflector E-Coat
29	1960353	1	WASHER
30	1710703	2	SPACER, Powdered Metal
31	1920397	2	NUT, Hex Lock ESNA Light 1/4-20
32	1704873	1	CLAMP, Wire
33	1919326	1	WASHER, 5/16
34	7101082	1	SPRING, Torsion Chute
35	1705449	1	DEFLECTOR
36	1715673	1	COVER, Arbor
37	1723323	1	CAP
38	1705115	1	PLUG, Button
39	1716870A	1	BAFFLE, Blowout 50" L.H. (CE/Export)
40	1735184A	1	BAFFLE, Blowout 50" R.H. (CE/Export)
41	1927557	3	NUT, Hex Flange 5/16-18 Whiz Lock Large
42	1931333	3	BOLT, Carriage, 5/16-18 x 3/4
43	1724538A	1	BAFFLE, Blowout (Domestic)

### Footnotes

The above parts group applies to the following Mfg. Nos.:

2691112-00 - Broadmoor

# 50" Mower Deck - Housing, Arbors & Blades Group

2987520

**NOTE:** Unless noted otherwise, use the standard hardware torque specification chart.

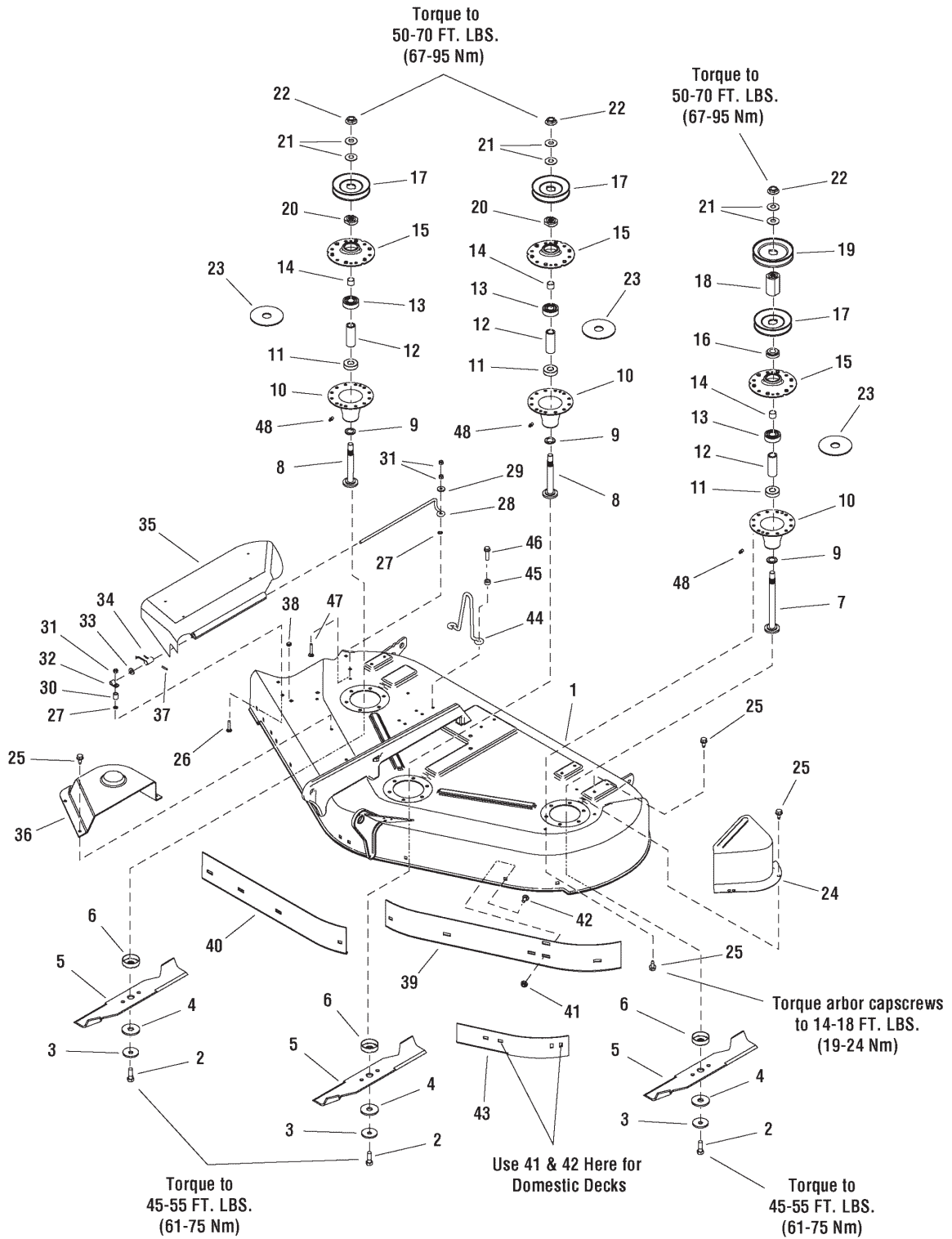

**The above parts group applies to the following Mfg. Nos.:**

2691112-00 - Broadmoor

## **50" Mower Deck - Housing, Arbors & Blades Group**

---

<b>REF NO</b>	<b>PART NO.</b>	<b>QTY.</b>	<b>DESCRIPTION</b>
44	1722748A	1	UPSTOP
45	1611705	2	SPACER
46	1931202	2	SCREW, Hex Washer Taptite
47	1960633	2	CARRIAGE BOLT, 1/4-20 x 1-1/2 G5
48	1704314	3	FITTING, Grease, 1/4 Drive

---

### **Footnotes**

---

**The above parts group applies to the following Mfg. Nos.:**

2691112-00 - Broadmoor

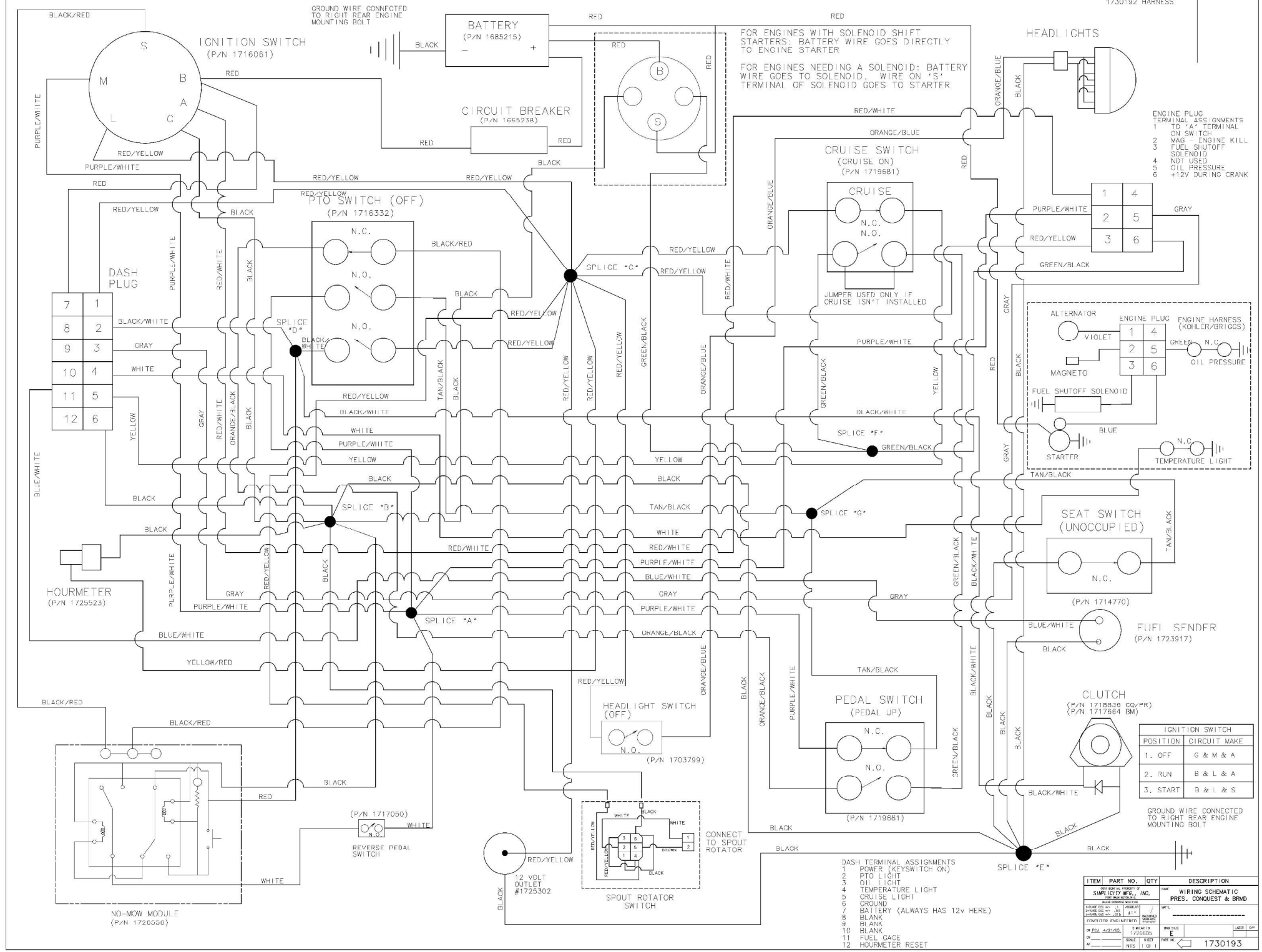

ENGINE PLUG TERMINAL ASSIGNMENTS TO 7-TERM. SWITCH

1	4
2	5
3	6

1 MAG. ENGINE KILL  
 2 FUEL SHUT-OFF SOLENOID  
 3 NOT USED  
 4 OIL PRESSURE  
 5 +12V DURING CRANK

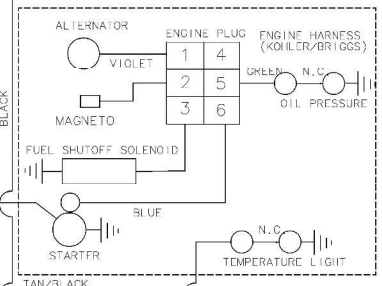

IGNITION SWITCH	
POSITION	CIRCUIT MAKE
1. OFF	G & M & A
2. RUN	B & L & A
3. START	B & L & S

GROUND WIRE CONNECTED TO RIGHT REAR ENGINE MOUNTING BOLT

- DASH TERMINAL ASSIGNMENTS
- 1 POWER (KEYSWITCH ON)
  - 2 PTO LIGHT
  - 3 OIL LIGHT
  - 4 TEMPERATURE LIGHT
  - 5 CRUISE LIGHT
  - 6 GROUND
  - 7 BATTERY (ALWAYS HAS 12V HERE)
  - 8 BLANK
  - 9 BLANK
  - 10 BLANK
  - 11 FUEL GAGE
  - 12 HOURMETER RESET

ITEM	PART NO.	QTY	DESCRIPTION
PREPARED BY: PRES. CONQUEST & BRND WIRING SCHEMATIC DATE: _____			
CHECKED BY: _____ DATE: _____			
DRAWN BY: _____ DATE: _____			
SCALE: _____ SHEET NO. 1 OF 1			







# Hardware Identification & Torque Specifications

Torque Specification Chart								
FOR STANDARD METRIC MACHINE HARDWARE (Tolerance ± 20%)								
Property Class	5.6		8.8		10.9		12.9	
	Class 5.6		Class 8.8		Class 10.9		Class 12.9	
Size Of Hardware	in/lbs	Nm.	in/lbs	Nm.	in/lbs	Nm.	in/lbs	Nm.
	ft/lbs		ft/lbs		ft/lbs		ft/lbs	
M3	5.88	.56	13.44	1.28	19.2	1.80	22.92	2.15
M4	13.44	1.28	30.72	2.90	43.44	4.10	52.56	4.95
M5	26.4	2.50	60.96	5.75	5.97	8.10	7.15	9.7
M6	44.64	4.3	7.3	9.9	10.3	14	12.1	16.5
M7	5.2	7.1	12.1	16.5	16.9	23	19.9	27
M8	7.7	10.5	17.7	24	25	34	29	40
M10	15	21	35	48	50	67	59	81
M12	26	36	61	83	86.2	117	103	140
M14	42	58	101	132	136	185	162	220
M16	64	88	147	200	210	285	250	340
M18	89	121	202	275	287	390	346	470
M20	126	171	290	390	405	550	486	660
M22	169	230	390	530	559	745	656	890
M24	217	295	497	375	708	960	840	1140
M27	320	435	733	995	1032	1400	1239	1680
M30	435	590	995	1350	1401	1900	1681	2280
M33	590	800	1349	1830	1902	2580	2278	3090
M36	759	1030	1740	2360	2441	3310	2935	3980
M39	988	1340	2249	3050	3163	4290	3798	5150

The guides and ruler furnished below are designed to help you select the appropriate hardware.



**Nut, M8**

Thread Diameter (mm)  
Inside Diameter (in)  
Threads per inch

**Nut, 1/2-16**

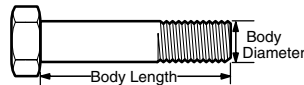

**Screw, M8 - 1.25 x 25**

Thread Diameter (mm)  
Body Diameter  
Distance between threads (mm)  
Threads per inch  
Body Length (mm)  
Body Length (in)

**Screw, 1/2- 16 x 2**

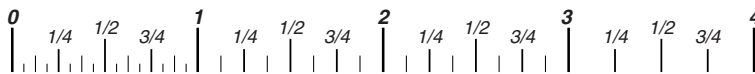

## Standard Hardware Sizing

When a washer or nut is identified as **1/2"** (M8), this is the *Nominal size*, meaning the *inside diameter* is 1/2 inch (8mm metric thread diameter); if a second number is present it represents the *threads per inch* (distance between threads).

When bolt or capscrew is identified as **1/2 - 16 x 2"** (M8 - 1.25 x 50 ), this means the *Nominal size*, or body diameter is 1/2 inch (8mm metric thread diameter), the second number, 16, represents the *threads per inch*, (1.25 thread diameter). The final number is the body length of the bolt or screw, 2 inches (50mm).

Torque Specification Chart						
FOR STANDARD MACHINE HARDWARE (Tolerance ± 20%)						
Hardware Grade	No Marks		SAE Grade 5		SAE Grade 8	
	SAE Grade 2		SAE Grade 5		SAE Grade 8	
Size Of Hardware	in/lbs	Nm.	in/lbs	Nm.	in/lbs	Nm.
	ft/lbs		ft/lbs		ft/lbs	
8-32	19	2.1	30	3.4	41	4.6
8-36	20	2.3	31	3.5	43	4.9
10-24	27	3.1	43	4.9	60	6.8
10-32	31	3.5	49	5.5	68	7.7
1/4-20	66	7.6	8	10.9	12	16.3
1/4-28	76	8.6	10	13.6	14	19.0
5/16-18	11	15.0	17	23.1	25	34.0
5/16-24	12	16.3	19	25.8	29	34.0
3/8-16	20	27.2	30	40.8	45	61.2
3/8-24	23	31.3	35	47.6	50	68.0
7/16-14	30	40.8	50	68.0	70	95.2
7/16-20	35	47.6	55	74.8	80	108.8
1/2-13	50	68.0	75	102.0	110	149.6
1/2-20	55	74.8	90	122.4	120	163.2
9/16-12	65	88.4	110	149.6	150	204.0
9/16-18	75	102.0	120	163.2	170	231.2
5/8-11	90	122.4	150	204.0	220	299.2
5/8-18	100	136	180	244.8	240	326.4
3/4-10	160	217.6	260	353.6	386	525.0
3/4-16	180	244.8	300	408.0	420	571.2
7/8-9	140	190.4	400	544.0	600	816.0
7/8-14	155	210.8	440	598.4	660	897.6
1-8	220	299.2	580	788.8	900	1,244.0
1-12	240	326.4	640	870.4	1,000	1,360.0

## NOTES

- These torque values are to be used for all hardware excluding: locknuts, self-tapping screws, thread forming screws, sheet metal screws and socket head setscrews.
- Recommended seating torque values for locknuts:
  - for prevailing torque locknuts - use 65% of grade 5 torques.
  - for flange whizlock nuts and screws - use 135% of grade 5 torques.
- Unless otherwise noted on assembly drawings, all torque values must meet this specification.

## Common Hardware Types

Hex Head Capscrew



Washer

Carriage Bolt



Lockwasher



Hex Nut

## Wrench & Fastener Size Guide

1/4" Bolt or Nut Wrench—7/16"	5/16" Bolt or Nut Wrench—1/2"	3/8" Bolt or Nut Wrench—9/16"	7/16" Bolt or Nut Wrench (Bolt)—5/8" Wrench (Nut)—11/16"	1/2" Bolt or Nut Wrench—3/4"
M6 Bolt or Nut Wrench—10mm	M8 Bolt or Nut Wrench—13mm	M10 Bolt or Nut Wrench—17mm	M12 Bolt or Nut Wrench—19mm	M14 Bolt or Nut Wrench—22mm



**IT IS THE POLICY OF BRIGGS & STRATTON CORP. TO IMPROVE ITS PRODUCTS  
WHENEVER IT IS POSSIBLE AND PRACTICAL TO DO SO. WE RESERVE THE RIGHT TO  
MAKE CHANGES OR ADD IMPROVEMENTS AT ANY TIME WITHOUT INCURRING ANY  
OBLIGATION TO MAKE SUCH CHANGES ON PRODUCTS.**

**Briggs & Stratton Yard Power Products Group**

---

3515 N. 124 Street / PO Box 702  
Wauwatosa, WI 53222 USA

[www.simplicitymfg.com](http://www.simplicitymfg.com)

© Copyright 2013 by Briggs & Stratton Corporation  
Milwaukee, WI, USA. All rights reserved