



# Parts Manual



## Coronet / 400 / 2400

### Series Riders & Mower Decks

#### 13.5HP Product

Mfg. No.	Description
2690800	Coronet, 13.5HP Hydro RMO and 30" Mower Deck

#### 13HP Product

Mfg. No.	Description
1694462	Coronet, 13HP Hydro
1694464	2413H, 13HP Hydro
1694510	Coronet, 13HP Hydro (CE/Export)
1694536	2413, 13HP Hydro (CE/Export)

#### 16HP Product

Mfg. No.	Description
1694463	Coronet, 16HP Hydro
2690802	Coronet, 16HP Hydro RMO and 34" Mower Deck

#### Mower Decks

Mfg. No.	Description
1692543	30" Mower Deck
1694053	30" Mower Deck
1694511	30" Mower Deck (CE/Export)
1694537	30" Mower Deck
1692545	34" Mower Deck

Manual Part No. 1731142

Revision B

Rev. Date: 7/8/2010



---

<b>PRODUCT COMPONENTS</b>	<b>PAGES</b>
Frame & Fuel System Group .....	4
Steering & Lift Group .....	8
Engine Group - 13HP Briggs & Stratton (CE/Export) .....	10
Engine Group - 13HP Briggs & Stratton Intek .....	12
Engine Group - Electric Clutch - 13HP Briggs & Stratton, INTEK .....	14
Engine Group - Electric Clutch - 16HP Kohler CV460 .....	16
Engine Group .....	18
Engine Group .....	20
Transmission Group - Hydro-Gear 340-0510 .....	22
Transmission SERVICE PARTS - Hydro-Gear 340-0510 .....	26
Electrical Group .....	32
Electrical Group .....	34
Electrical Group .....	38
Front Column & Dash Group .....	40
Wheels & Tires Group .....	44
Decals Group - Brand & Model .....	46
Decals Group - Common & Safety .....	48
30" Mower Deck - Drive & Arbor .....	50
30" Mower Deck - Housing & Height Adjustment (CE/Export) .....	52
30" Mower Deck - Housing, Hitch & Height Adjustment .....	56
34" Mower Deck - Drive & Arbor .....	60
34" Mower Deck - Height Adjustment .....	62
34" Mower Deck - Housing, Hitch & Deflector .....	64
<b>Torque Specification Chart .....</b>	<b>Inside Back Cover</b>

# Frame & Fuel System Group

986408

NOTE: Unless noted otherwise,  
use the standard hardware torque  
specification chart.

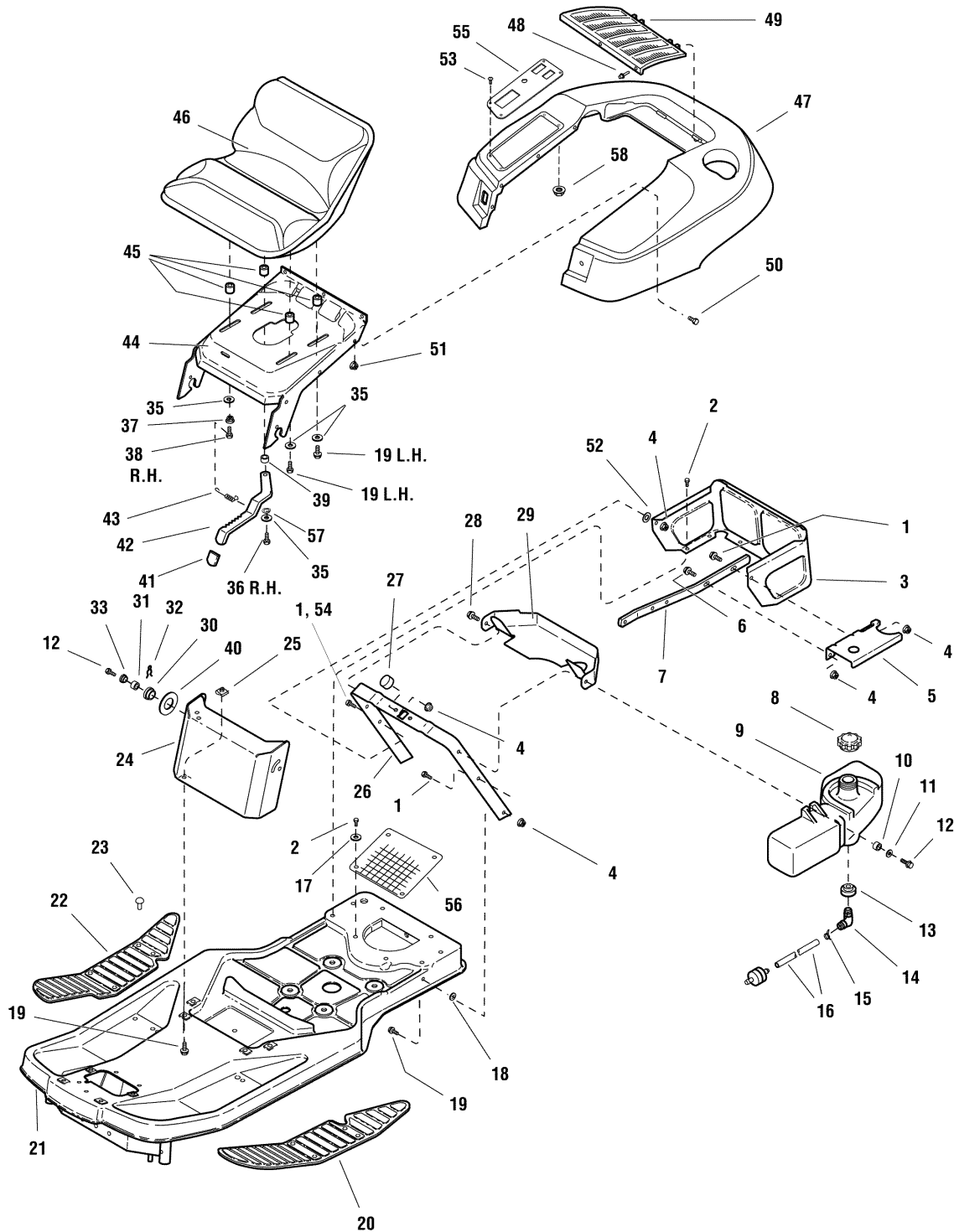

The above parts group applies to the following Mfg. Nos.:

- 1694462 - Coronet      2690802 - Coronet
- 1694463 - Coronet
- 1694464 - 2413H
- 1694510 - Coronet
- 1694536 - 2413
- 2690800 - Coronet

## Frame & Fuel System Group

REF NO	PART NO.	QTY.	DESCRIPTION
1	1921333SM	2	CAPSCREW, Hex Head, 5/16-18 x 1
2	1925003SM	8	CAPSCREW, Hex Head, Taptite, 1/4-20 x 1/2
3	1715962ASM	1	SHROUD, Rear
4	1931277SM	5	NUT, Hex, Flange, Whizlock, 5/16-18
5	1726558ASM	1	SUPPORT, Fuel Tank
6	1931333SM	1	CARRIAGE BOLT, 5/16-18 x 3/4
7	1708362ASM	1	STRAP, Fuel Tank, Brace
8	1714020SM	1	CAP, Fuel Tank, Vented
9	1726635SM	1	TANK, Fuel
10	1710437SM	1	SPACER, 21/64 x 1/2 x 21/64
11	1924940SM	1	WASHER, Plain, 13/32 x 7/8 x 5/64
12	1931202SM	1	CAPSCREW, Taptite, 5/16-18 x 1-1/4 Black (16HP Models)
12	1960373SM	1	CAPSCREW, Hex, Taptite, 5/16-18 x 1 Black (13 HP Models)
13	1726400SM	1	BUSHING, Rubber
14	1674792SM	1	ELBOW, Fitting with Screen
15	791850	2	CLAMP, Hose
16	1734981SM	1	HOSE, Fuel Line
17	1960044SM	2	WASHER, Plain
18	1933988SM	2	PUSH NUT, 5/16
19	1930591SM	10	CAPSCREW, Hex Head, Whizlock, 5/16-18 x 3/4
20	1708525SM	1	PAD, Foot Rest, LH
21	1660915ASM	1	FRAME ASSEMBLY
22	1708524SM	1	PAD, Foot Rest, RH
23	1704351SM	14	FASTENER
24	1727685ASM	1	PANEL, Front
25	1935255SM	4	PAL NUT, 5/16-18
26	1726563ASM	1	SUPPORT, "U", Seat (16 HP Models)
26	1726563ASM	1	SUPPORT, "U", Seat (13 HP Models)
27	1715970SM	2	BUMPER, Rubber
28	1924856SM	1	CAPSCREW, Hex Head, Taptite, 5/16 x 1/2
29	1708725ASM	1	DUCT, Air Inlet (13 HP Models)
29	1726971ASM	1	DUCT, Air Inlet (16 HP Models)
30	1704626SM	2	SPACER, Plastic
31	1705249SM	2	SPACER
32	1704628SM	2	PIN, Quick
33	1705248SM	2	PIVOT, Hood
35	1917356SM	4	WASHER
36	1921221SM	1	CAPSCREW, Hex Head, 5/16-18 x 1-1/2
37	1917372SM	1	NUT, Hex, 5/16-18
38	1921977SM	1	CAPSCREW, 5/16-18 x 1-1/4
39	1703900SM	1	SPACER
40	2860208SM	2	WASHER, 1"
41	1708881SM	1	CAP, Black, Vinyl

### Footnotes

---

#### The above parts group applies to the following Mfg. Nos.:

1694462 - Coronet      2690802 - Coronet  
 1694463 - Coronet  
 1694464 - 2413H  
 1694510 - Coronet  
 1694536 - 2413  
 2690800 - Coronet

## Frame & Fuel System Group

986408

NOTE: Unless noted otherwise,  
use the standard hardware torque  
specification chart.

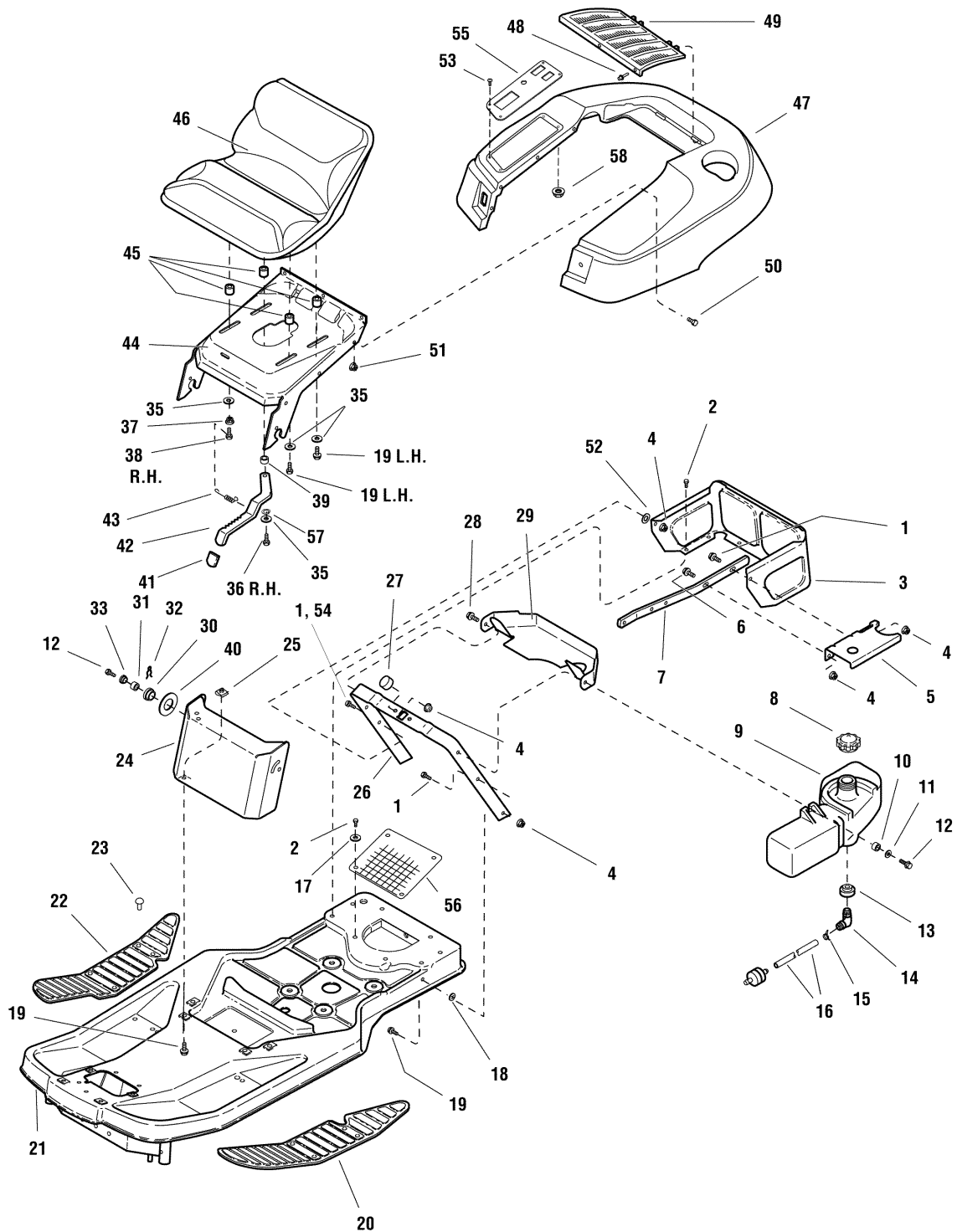

The above parts group applies to the following Mfg. Nos.:

- 1694462 - Coronet      2690802 - Coronet
- 1694463 - Coronet
- 1694464 - 2413H
- 1694510 - Coronet
- 1694536 - 2413
- 2690800 - Coronet

## Frame & Fuel System Group

REF NO	PART NO.	QTY.	DESCRIPTION
42	1725532ASM	1	ADJUSTER, Seat
43	1667286SM	1	SPRING, Extension
44	1725531ASM	1	SUPPORT, Seat
45	1708511SM	4	SPACER
46	1725486SM	1	SEAT ASSEMBLY
47	1734144SM	1	DECK, Seat, Orange Simplicity
47	1734145SM	1	DECK, Seat, Red
47	1686638SM	1	DECK, Seat, Orange Agco Allis
48	1673320SM	3	RIVET
49	7102141SM	1	SCREEN, Seat Deck Top
50	1960295SM	7	CAPSCREW, Hex Head, Whizlock, 1/4-20 x 5/8
51	1930642SM	7	NUT, Hex, Flange Lock, 1/4-20
52	1919381SM	1	WASHER, 5/16
53	1960715SM	4	SCREW, Truss Head, 1/4-20 x 3/4
54	1922127SM	1	CAPSCREW, Hex Head, 5/16-18 x 1-3/4 (16 HP Models)
55	1726836ASM	1	PLATE, Control
56	1724598SM	1	SCREEN
57	1919381SM	4	WASHER, 11/32 x 1 x 1/8
58	1920397SM	1	NUT, ESNA 1/4-20

## Footnotes

---

### The above parts group applies to the following Mfg. Nos.:

1694462 - Coronet      2690802 - Coronet  
1694463 - Coronet  
1694464 - 2413H  
1694510 - Coronet  
1694536 - 2413  
2690800 - Coronet

## Steering & Lift Group

984685SL

**NOTE:** Unless noted otherwise,  
use the standard hardware torque  
specification chart.

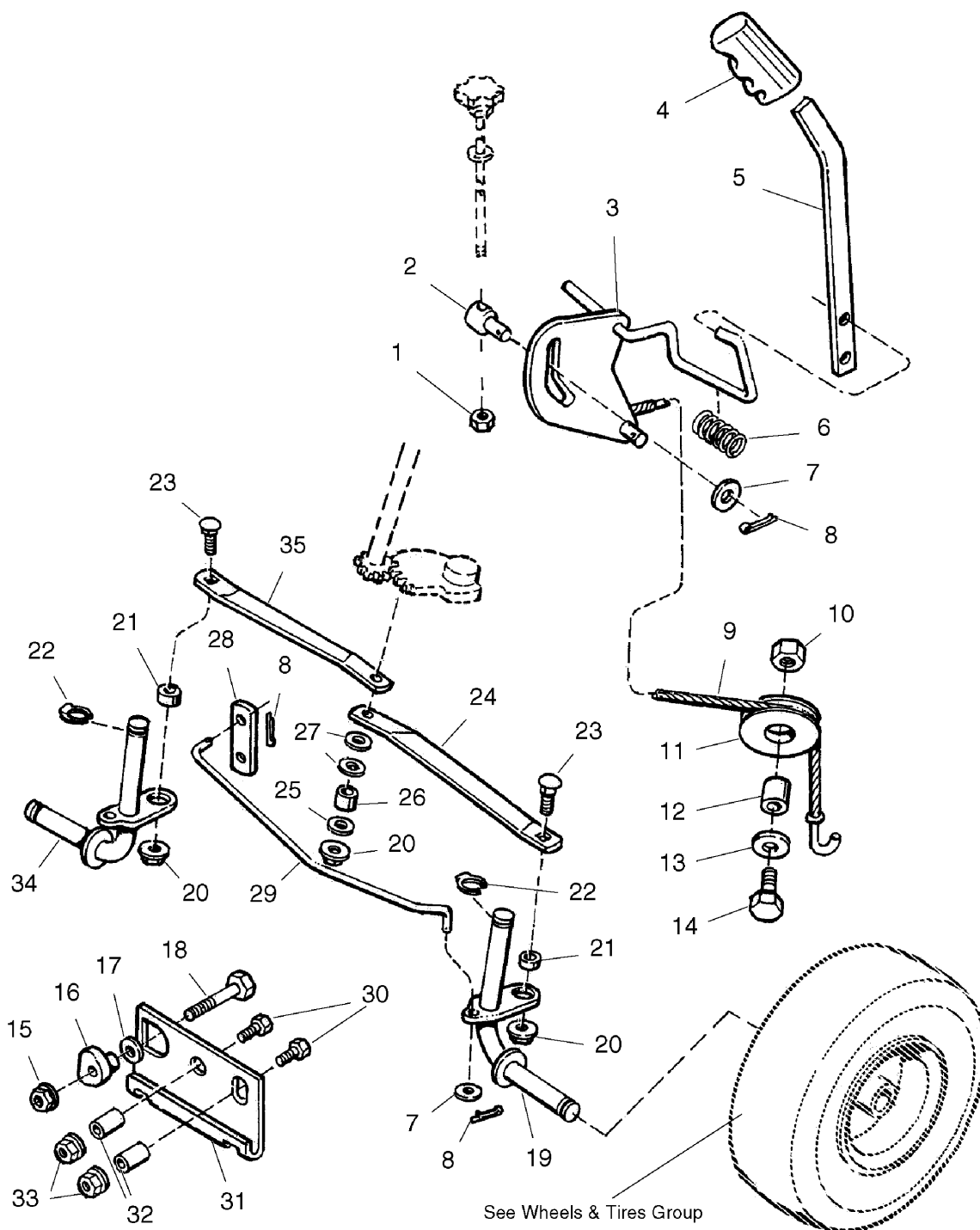

**The above parts group applies to the following Mfg. Nos.:**

1694462 - Coronet      2690802 - Coronet  
1694463 - Coronet  
1694464 - 2413H  
1694510 - Coronet  
1694536 - 2413  
2690800 - Coronet



## Steering & Lift Group

REF NO	PART NO.	QTY.	DESCRIPTION
1	1930645SM	1	NUT, Hex, 3/8-16
2	2108512SM	1	PIVOT
3	1708955ASM	1	ARM ASSEMBLY, Lift
4	1708966SM	1	GRIP, Lever
5	1708557ASM	1	LEVER, Lift
6	1708884SM	1	SPRING, Compression
7	1924940SM	3	WASHER, Plain, 13/32 x 7/8 x 5/64
8	1918447SM	3	COTTER PIN, 3/32 x 3/4
9	1708556SM	1	CABLE ASSEMBLY, Lift
10	1919439SM	1	NUT, Hex, Esna Lock, 3/8-16
11	1708559SM	1	PULLEY, Lift
12	1708973SM	1	SPACER
13	1924356SM	1	WASHER, Plain, 13/32 x 1-1/2 x 1/8
14	1921969SM	1	CAPSCREW, Hex Head, 3/8-16 x 1-1/2
15	1930645SM	1	NUT, Hex, Flange Lock, 3/8-16
16	1708514SM	1	ECCENTRIC
17	1922755SM	1	WASHER, 13/32 x 7/8 x 1/8
18	1921971SM	1	CAPSCREW, Hex Head, 3/8-16 x 1-3/4
19	1706011SM	1	SPINDLE ASSEMBLY, LH
20	1935048SM	3	NUT, Hex, Flange Lock, 5/16-18
21	1960236SM	2	SPACER
22	1611710SM	2	KLIP RING
23	1960655SM	2	CARRIAGE BOLT, 5/16-18 x 1-1/4
24	1708501ASM	1	TIE ROD, LH
25	1919381SM	1	WASHER
26	1710703SM	1	SPACER, 21/64 x 1/2 x 5/8
27	1960170SM	2	WASHER
28	1708516ASM	1	LEVER
29	1708521SM	1	ROD, Hitch
30	1920328SM	2	CAPSCREW, Hex Head, 1/2-13 x 1-1/2
31	1709237ASM	1	HITCH, Hook
32	1709235SM	2	SPACER
33	1930644SM	2	NUT, Hex, Flange Lock, 1/2-13
34	1706011SM	1	SPINDLE ASSEMBLY, RH
35	1708500ASM	1	TIE ROD, RH

## Footnotes

---

### The above parts group applies to the following Mfg. Nos.:

1694462 - Coronet      2690802 - Coronet  
1694463 - Coronet  
1694464 - 2413H  
1694510 - Coronet  
1694536 - 2413  
2690800 - Coronet

# Engine Group - 13HP Briggs & Stratton (CE/Export)

986570

NOTE: Unless noted otherwise,  
use the standard hardware torque  
specification chart.

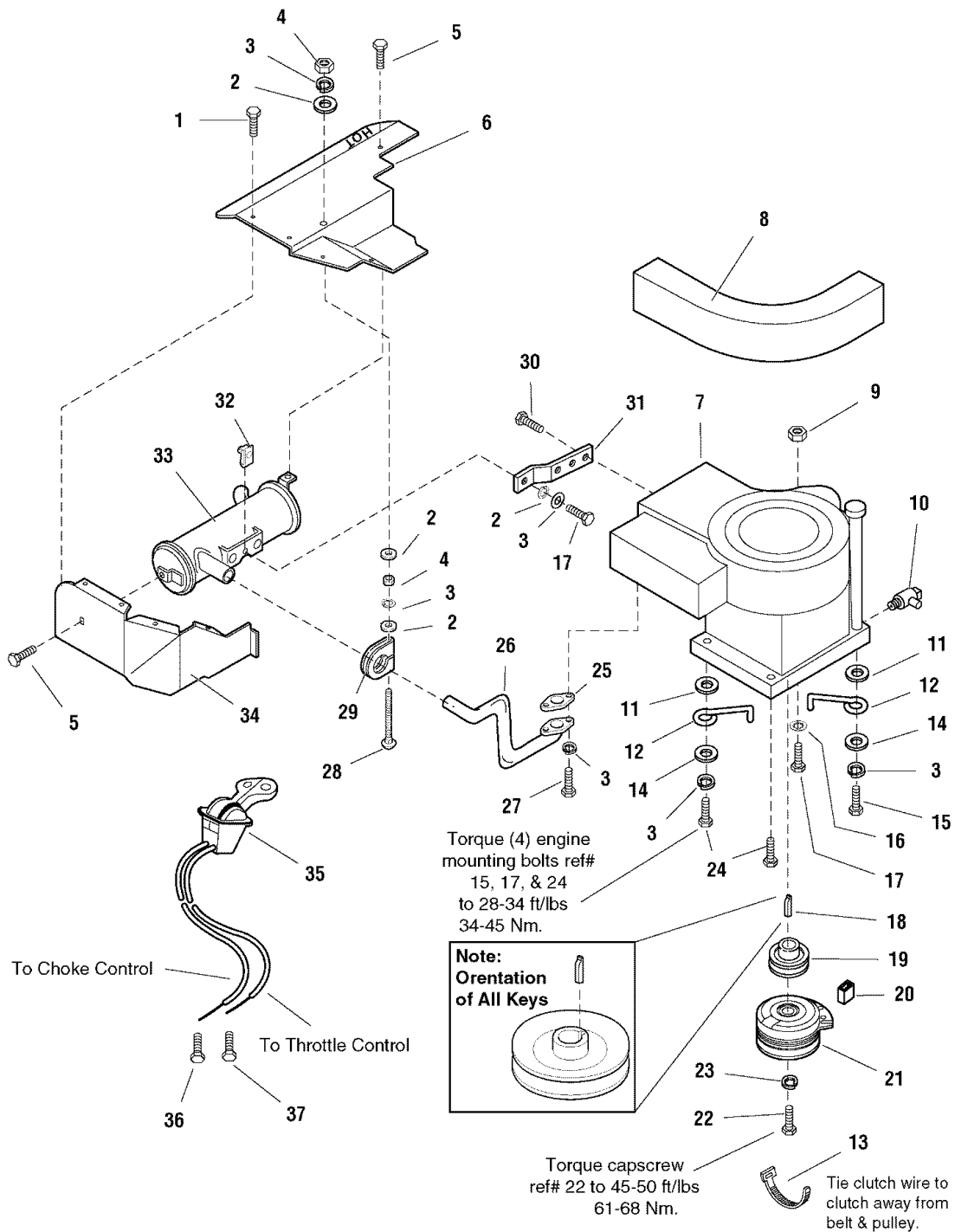

The above parts group applies to the following Mfg. Nos.:

1694536 - 2413

## Engine Group - 13HP Briggs & Stratton (CE/Export)

REF NO	PART NO.	QTY.	DESCRIPTION
1	1960720SM	4	CAPSCREW, Self-Tapping, #10-16 x 1/2
2	1919326SM	4	WASHER, 5/16
3	1917356SM	8	LOCKWASHER, 5/16
4	1917372SM	2	NUT, Hex, 5/16-18
5	1924856SM	2	CAPSCREW, Hex Head, Taptite, 5/16-18 x 1/2
6	1724426ASM	1	DUCT, R.H., Top
7	*	1	ENGINE, Briggs & Stratton, 13HP, Model 21A907922858
8	1709055SM	1	SEAL, Air Inlet
9	1931277SM	3	NUT, Flange, Whizlock, 5/16-18
10	1708405SM	1	VALVE, Shut-Off
11	1933263SM	2	WASHER, Plain
12	1704419SM	2	BELT STOP
13	1701011SM	1	TIE, Self Locking
14	1922755SM	2	WASHER, 3/8
15	2860361SM	1	CAPSCREW, Taptite, 3/8-16 x 2
16	1933988SM	1	PUSH NUT, 5/16-18
17	1933689SM	1	CAPSCREW, Hex, Whizlock, Flange, 5/16-18 x 1-1/2
18	2171241SM	1	** KEY
19	1709218SM	1	PULLEY, Engine
20	1708537SM	1	SLEEVE, Clutch Anchor
21	1686882SM	1	CLUTCH, Electric, Kit
22	1960370SM	1	CAPSCREW, Hex Head, 7/16-20 x 2-1/2
23	1918199SM	1	LOCKWASHER, 7/16
24	1930598SM	2	CAPSCREW, Taptite, 3/8-16 x 1-1/2
25	1650670SM	1	GASKET, Muffler
26	1724466SM	1	PIPE, Exhaust
27	1936228SM	2	CAPSCREW, Socket Head, 5/16-18 x 3/4
28	1960748SM	1	CARRIAGE BOLT, 5/16-18 x 3-1/4
29	1676183SM	1	CLAMP, Muffler
30	1960568SM	2	CAPSCREW, Hex Head, 1/4-20 x 7/8
31	1724428ASM	1	SUPPORT, Muffler
32	1935255SM	1	SPEED NUT, 5/16-18
33	1708416SM	1	MUFFLER ASSEMBLY
34	1724427ASM	1	DUCT, L.H.
35	1727223SM	1	CONTROL, Throttle Double 39" Long w/Knobs
36	1726787SM	1	SCREW, Thread Forming W/Washer, B&S #95220
37	1726788SM	1	SCREW, Hex, Washer Head, B&S #94909
38	1708442SM	1	STOP, Throttle (Not Pictured, Export Models Only)

### Footnotes

Note\* See your local Briggs & Stratton distributor for parts & service.

Note\*\* Key MUST be installed as shown to prevent damage to electric clutch.

---

**The above parts group applies to the following Mfg. Nos.:**

1694536 - 2413

# Engine Group - 13HP Briggs & Stratton Intek

986489

**NOTE:** Unless noted otherwise,  
use the standard hardware torque  
specification chart.

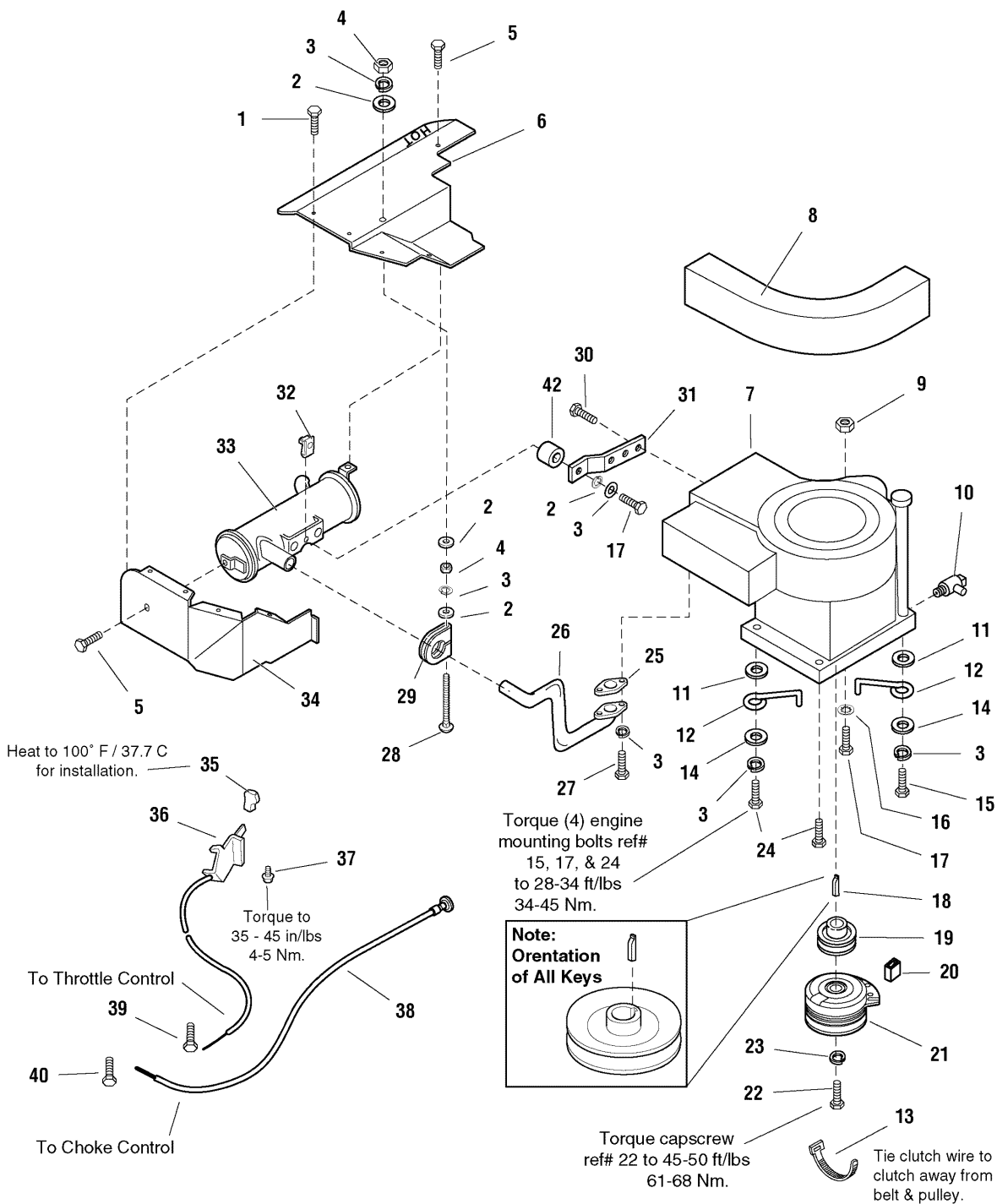

**The above parts group applies to the following Mfg. Nos.:**

1694510 - Coronet

## Engine Group - 13HP Briggs & Stratton Intek

REF NO	PART NO.	QTY.	DESCRIPTION
1	1960720SM	4	CAPSCREW, Self-Tapping, #10-16 x 1/2
2	1919326SM	4	WASHER, 5/16
3	1917356SM	7	LOCKWASHER, 5/16
4	1917372SM	2	NUT, Hex, 5/16-18
5	1924856SM	2	CAPSCREW, Hex Head, Taptite, 5/16-18 x 1/2
6	1724426ASM	1	DUCT, R.H., Top
7	*	1	ENGINE, Briggs & Stratton, 13HP, Model 21A907922858
8	1709055SM	1	SEAL, Air Inlet
9	1931277SM	3	NUT, Flange, Whizlock, 5/16-18
10	1708405SM	1	VALVE, Shut-Off
11	1933263SM	2	WASHER, Plain
12	1704419SM	2	BELT STOP
13	1701011SM	1	TIE, Self Locking
14	1922755SM	2	WASHER, 3/8
15	2860361SM	1	CAPSCREW, Taptite, 3/8-16 x 2
16	1933988SM	1	PUSH NUT, 5/16-18
17	1933689SM	1	CAPSCREW, Hex, Whizlock, Flange, 5/16-18 x 1-1/2
18	2171241SM	1	** KEY
19	1709218SM	1	PULLEY, Engine
20	1708537SM	1	SLEEVE, Clutch Anchor
21	1686882SM	1	CLUTCH, Electric, Kit
22	1960370SM	1	CAPSCREW, Hex Head, 7/16-20 x 2-1/2
23	1918199SM	1	LOCKWASHER, 7/16
24	1930598SM	2	CAPSCREW, Taptite, 3/8-16 x 1-1/2
25	1650670SM	1	GASKET, Muffler
26	1724466SM	1	PIPE, Exhaust
27	1936228SM	2	CAPSCREW, Socket Head, 5/16-18 x 3/4
28	1960748SM	1	CARRIAGE BOLT, 5/16-18 x 3-1/4
29	1676183SM	1	CLAMP, Muffler
30	1960568SM	2	CAPSCREW, Hex Head, 1/4-20 x 7/8
31	1724428ASM	1	SUPPORT, Muffler
32	1935255SM	1	SPEED NUT, 5/16-18
33	1708416SM	1	MUFFLER ASSEMBLY
34	1724427ASM	1	DUCT, L.H.
35	1713846SM	1	KNOB, Throttle
36	1714040SM	1	THROTTLE CONTROL ASSEMBLY
37	1960536SM	2	SCREW, Plastite, 1/4-10 x 1/2
38	1704344SM	1	CABLE, Choke Control
39	1726788SM	1	SCREW, Hex, Washer Head, B&S #94909
40	1726787SM	1	SCREW, Thread Forming W/Washer, B&S #95220
41	1708442SM	1	STOP, Throttle (Not Pictured, Export Models Only)
42	2157081SM	1	SPACER

### Footnotes

Note\* See your local Briggs & Stratton distributor for parts & service.

Note\*\* Key MUST be installed as shown to prevent damage to electric clutch.

---

**The above parts group applies to the following Mfg. Nos.:**

1694510 - Coronet

# Engine Group - Electric Clutch - 13HP Briggs & Stratton, INTEK

986211

NOTE: Unless noted otherwise,  
use the standard hardware torque  
specification chart.

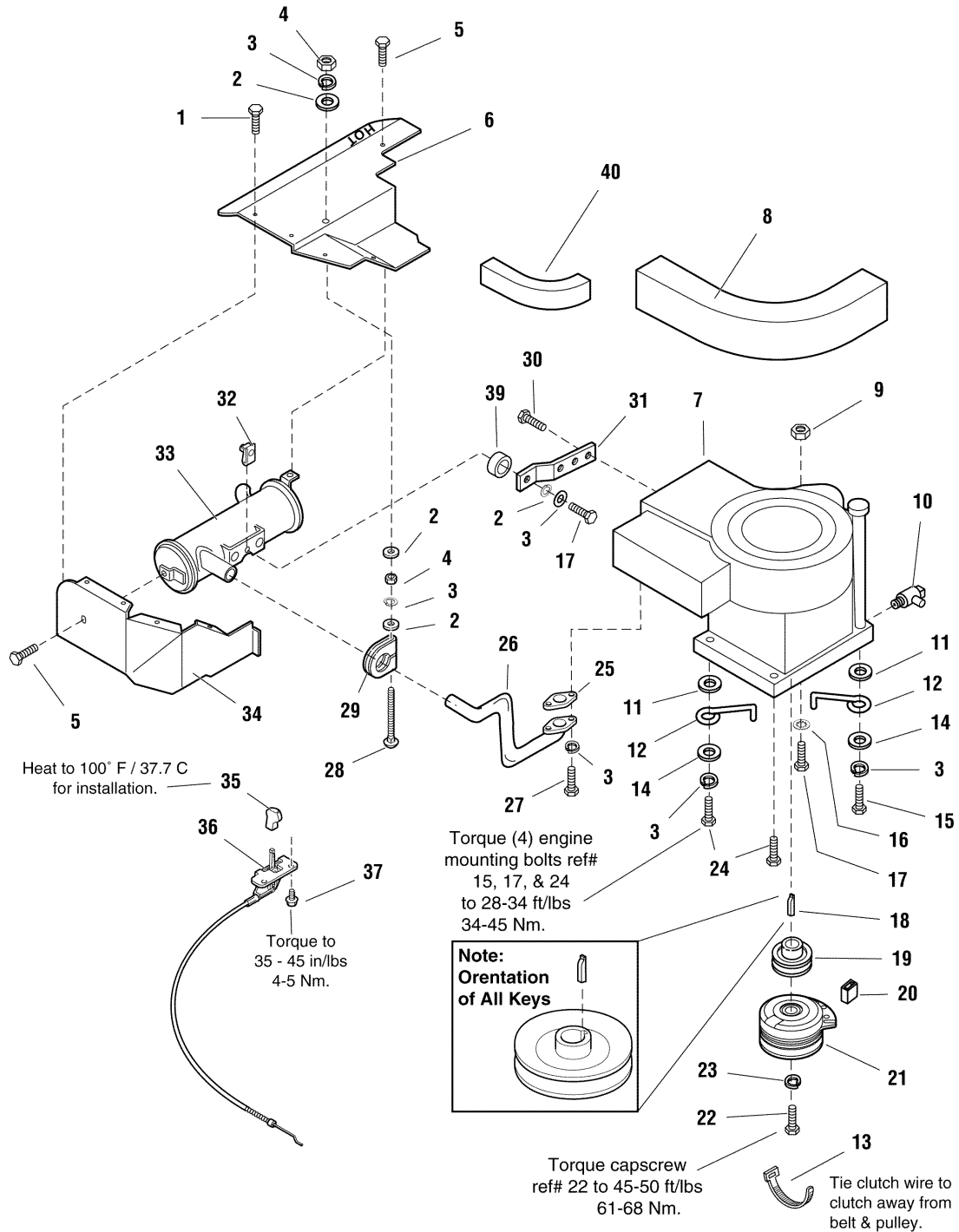

The above parts group applies to the following Mfg. Nos.:

- 1694462 - Coronet
- 1694464 - 2413H

## Engine Group - Electric Clutch - 13HP Briggs & Stratton, INTEK

REF NO	PART NO.	QTY.	DESCRIPTION
1	1960720SM	5	CAPSCREW, Self-Tapping, #10-16 x 1/2
2	1919326SM	4	WASHER, 5/16
3	1917356SM	8	LOCKWASHER, 5/16
4	1917372SM	2	NUT, Hex, 5/16-18
5	1924856SM	2	CAPSCREW, Hex Head, Taptite, 5/16-18 x 1/2
6	1724426ASM	1	DUCT, R.H., Top
7	*	1	ENGINE, Briggs & Stratton, 13HP, Model 21A907922858
8	1709055SM	1	SEAL, Air Inlet
9	1931277SM	3	NUT, Flange, Whizlock, 5/16-18
10	1708405SM	1	VALVE, Shut-Off
11	1933263SM	2	WASHER, Plain
12	1704419SM	2	BELT STOP
13	1701011SM	1	TIE, Self Locking
14	1922755SM	2	WASHER, 3/8
15	2860361SM	1	CAPSCREW, Taptite, 3/8-16 x 2
16	1933988SM	1	PUSH NUT, 5/16-18
17	1933689SM	1	CAPSCREW, Hex, Whizlock, Flange, 5/16-18 x 1-1/2
18	2171241SM	1	** KEY
19	1709218SM	1	PULLEY, Engine
20	1708537SM	1	SLEEVE, Clutch Anchor
21	1686882SM	1	CLUTCH, Electric, Kit
22	1960370SM	1	CAPSCREW, Hex Head, 7/16-20 x 2-1/2
23	1918199SM	1	LOCKWASHER, 7/16
24	1930598SM	2	CAPSCREW, Taptite, 3/8-16 x 1-1/2
25	1650670SM	1	GASKET, Muffler
26	1724466SM	1	PIPE, Exhaust
27	1936228SM	2	CAPSCREW, Socket Head, 5/16-18 x 3/4
28	1960748SM	1	CARRIAGE BOLT, 5/16-18 x 3-1/4
29	1676183SM	1	CLAMP, Muffler
30	1960568SM	2	CAPSCREW, Hex Head, 1/4-20 x 7/8
31	1724428ASM	1	SUPPORT, Muffler
32	1935255SM	1	SPEED NUT, 5/16-18
33	1708416SM	1	MUFFLER ASSEMBLY
34	1724427ASM	1	DUCT, L.H.
35	1713846SM	1	KNOB, Throttle
36	1714040SM	1	THROTTLE CONTROL ASSEMBLY
37	1960536SM	2	SCREW, Plastite, 1/4-10 x 1/2
38	1708442SM	1	STOP, Throttle (Not Pictured, Export Models Only)
39	2157081SM	1	SPACER
40	1718648SM	1	SEAL, Edging

### Footnotes

Note\* See your local Briggs & Stratton distributor for parts & service.

Note\*\* Key MUST be installed as shown to prevent damage to electric clutch.

---

### The above parts group applies to the following Mfg. Nos.:

1694462 - Coronet

1694464 - 2413H

# Engine Group - Electric Clutch - 16HP Kohler CV460

**NOTE:** Unless noted otherwise, use the standard hardware torque specification chart.

E986007

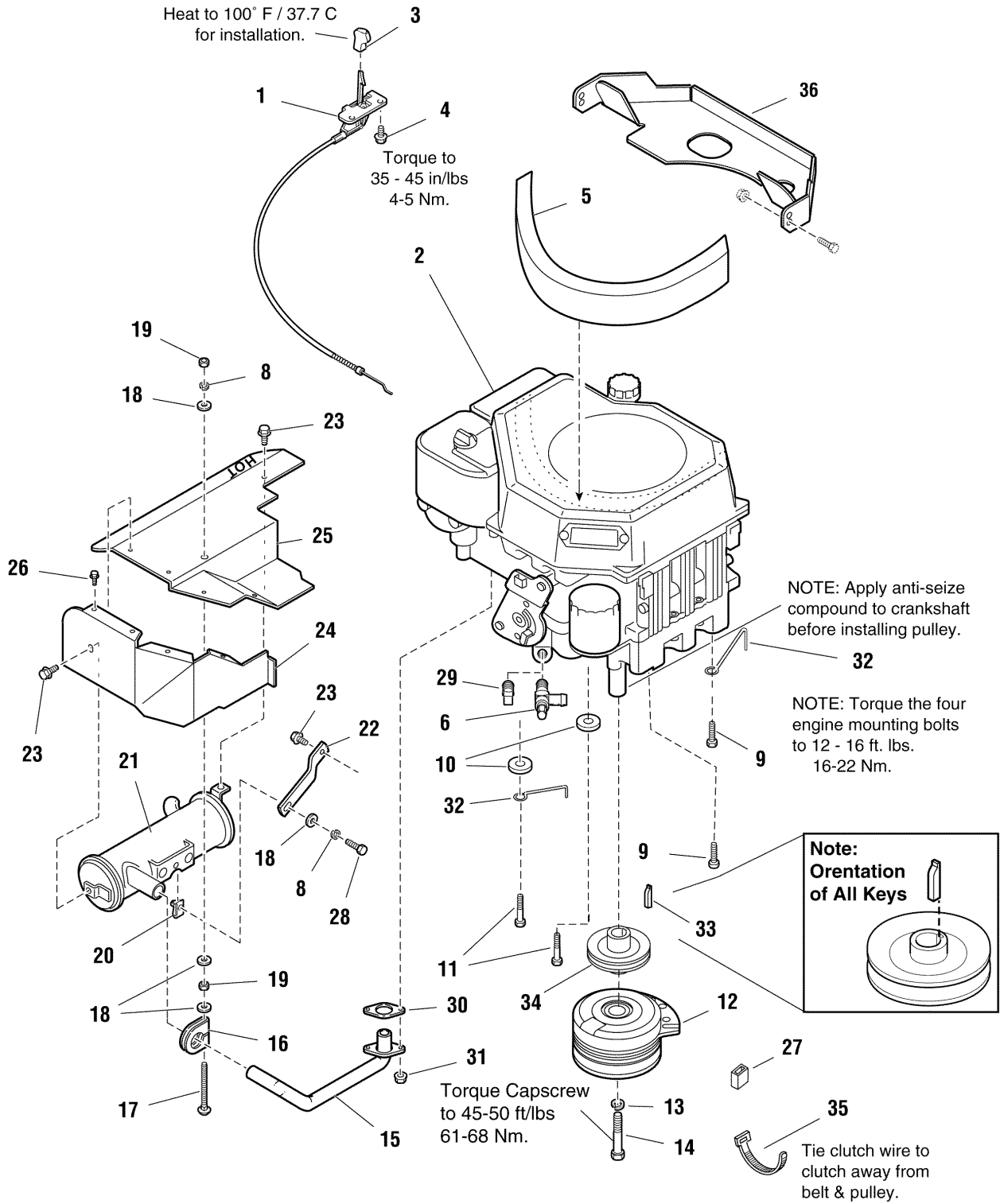

The above parts group applies to the following Mfg. Nos.:

1694463 - Coronet



## Engine Group - Electric Clutch - 16HP Kohler CV460

REF NO	PART NO.	QTY.	DESCRIPTION
1	1714065SM	1	THROTTLE CONTROL ASSEMBLY
2	*	1	ENGINE ASSEMBLY, 16 HP Kohler, Model CV 460, Type PA 26507
3	1713846SM	1	KNOB, Throttle
4	1960536SM	2	SCREW, Plastite, 1/4-10 x 1/2
5	1709055SM	1	SEAL, Air Inlet
6	1708405SM	1	VALVE, Shut Off
7	1919381SM	4	WASHER, Plain, 5/16
8	1917356SM	2	LOCKWASHER, 5/16
9	1928635SM	2	CAPSCREW, Hex Head TapTite 3/8-16 x 1-1/4
10	1933263SM	2	WASHER, Plain
11	1927187SM	2	CAPSCREW, Hex Head Washer TapTite 3/8-16 x 1, Black
12	1686882SM	1	CLUTCH, Electric, Kit
13	1918199SM	1	LOCKWASHER, 7/16
14	1960370SM	1	CAPSCREW, Hex, 7/16-20 x 2-1/2
15	1713502SM	1	PIPE, Exhaust
16	1676183SM	1	CLAMP, Muffler
17	1960748SM	1	CARRIAGE BOLT, 5/16-18 x 3-1/4
18	1919326SM	4	WASHER, 5/16
19	1917372SM	2	NUT, Hex, 5/16-18
20	1935255SM	1	NUT, Speed, 5/16-18
21	1708416SM	1	MUFFLER ASSEMBLY
22	1713557ASM	1	SUPPORT, Muffler
23	1924856SM	3	CAPSCREW, Hex, Taptite, 5/16-18 x 1/2
24	1722621ASM	1	AIR DUCT, Bottom
25	1726418SM	1	SHIELD, Muffler
26	1960720SM	5	CAPSCREW, Hex,Washer Head Thd. Form, #10-16 x 3/8
27	1708537SM	1	SLEEVE, Anchor, Clutch
28	1921333SM	1	CAPSCREW, Hex Head, 5/16-18 x 1
29	*	1	PLUG, Oil Drain
30	*	1	GASKET, Muffler
31	*	2	NUT, Hex Flange
32	1704419SM	2	BELT STOP
33	2171241SM	1	** KEY
34	1709218SM	1	PULLEY
35	1701011SM	1	TIE, Self Locking
36	1726971SM	1	AIR DUCT

### Footnotes

Note\* See your local Kohler distributor for parts & service.

Note\*\* Key MUST be installed as shown to prevent damage to electric clutch.

---

**The above parts group applies to the following Mfg. Nos.:**

1694463 - Coronet

# Engine Group

NOTE: Unless noted otherwise, use the standard hardware torque specification chart.

2988034

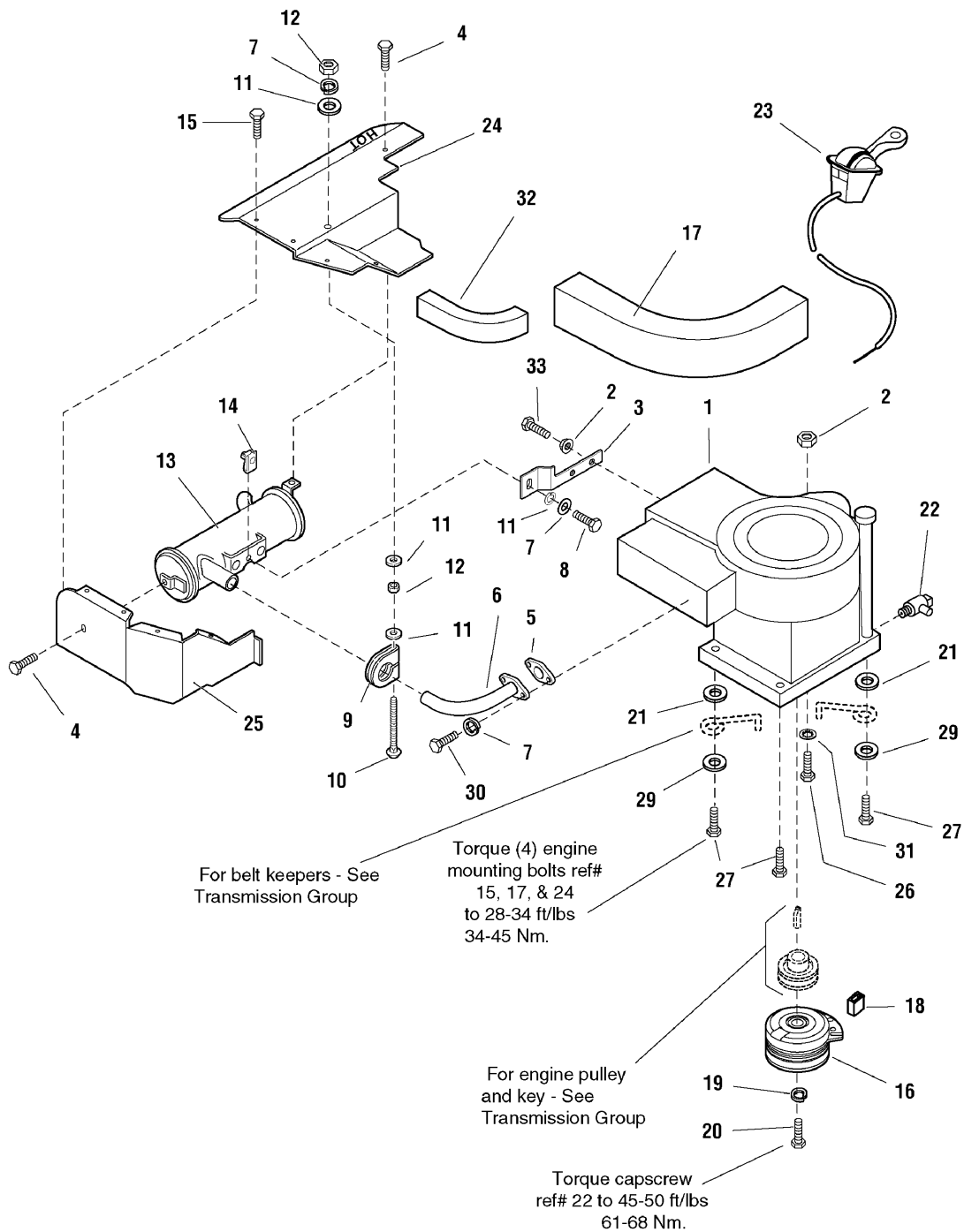

The above parts group applies to the following Mfg. Nos.:

2690800 - Coronet

## Engine Group

REF NO	PART NO.	QTY.	DESCRIPTION
1	20B9070203G1	1	ENGINE, Briggs & Stratton, 13.5HP * (20B9070203G1)
2	1931277SM	1	NUT, Hex Flange, 5/16-18
3	1724428ASM	1	SUPPORT, Muffler
4	1924856SM	2	CAPSCREW, Taptite, 5/16-18 x 1/2
5	1650670SM	1	GASKET, Muffler
6	1724466SM	1	PIPE, Exhaust
7	1917356SM	4	LOCKWASHER, 5/16
8	1921333SM	1	CAPSCREW, 5/16-18 x 1
9	1676183SM	1	CLAMP, Muffler
10	1960748SM	1	BOLT, Carriage, 5/16-18 x 3-1/4
11	1919326SM	4	WASHER, 5/16
12	1917372SM	2	NUT, Hex, 5/16-18
13	1708416SM	1	MUFFLER ASSEMBLY
14	1935255SM	1	NUT, Speed, 5/16-18
15	1960720SM	5	SCREW, #10-16 x 1/2
16	1686882SM	1	CLUTCH, Electric
17	1709055SM	1	SEAL, Air Inlet
18	1708537SM	1	SLEEVE, Clutch Anchor
19	1918199SM	1	LOCKWASHER, 7/16
20	1960370SM	1	CAPSCREW, 7/16-20 x 2-12
21	1933263SM	2	WASHER, Flat, 7/16
22	1708405SM	1	VALVE, Shut Off
23	1722955SM	1	THROTTLE CONTROL, Single
24	1724426ASM	1	DUCT, Top, R.H.
25	1724427ASM	1	DUCT, Bottom
26	1933689SM	1	CAPSCREW, Hex, Whiz, 5/16-18 x 1-1/2
27	1930598SM	3	CAPSCREW, Taptite, 3/8-16 x 1-1/2
29	1922755SM	2	WASHER, 3/8
30	1936228SM	2	CAPSCREW, Socket HEad, 5/16-18 x 3/4
31	1933988SM	1	PUSHNUT, 5/16
32	1718648SM	1	EDGING, Seal
33	1960568SM	2	CAPSCREW, Taptite, 1/4-20 x 7/8

### Footnotes

Note\* See your local Briggs & Stratton distributor for parts and service.

---

**The above parts group applies to the following Mfg. Nos.:**

2690800 - Coronet

# Engine Group

NOTE: Unless noted otherwise, use the standard hardware torque specification chart.

2988039

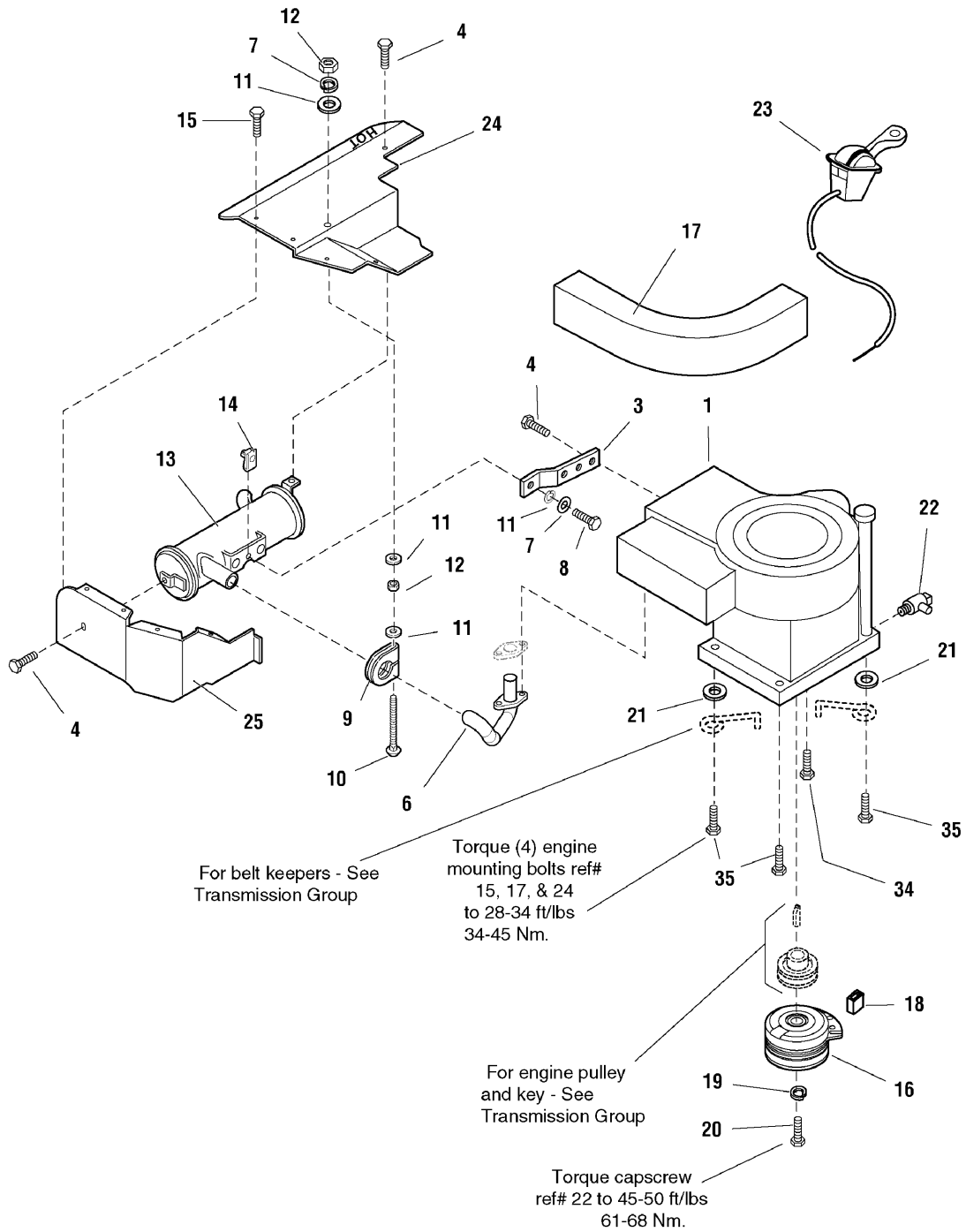

The above parts group applies to the following Mfg. Nos.:

2690802 - Coronet

## Engine Group

REF NO	PART NO.	QTY.	DESCRIPTION
1	-----	1	ENGINE, Briggs & Stratton, 16HP *
3	1713557ASM	1	SUPPORT, Muffler
4	1924856SM	3	CAPSCREW, Taptite, 5/16-18 x 1/2
6	1713502SM	1	PIPE, Exhaust
7	1917356SM	2	LOCKWASHER, 5/16
8	1921333SM	1	CAPSCREW, 5/16-18 x 1
9	1676183SM	1	CLAMP, Muffler
10	1960748SM	1	BOLT, Carriage, 5/16-18 x 3-1/4
11	1919326SM	4	WASHER, 5/16
12	1917372SM	2	NUT, Hex, 5/16-18
13	1708416SM	1	MUFFLER ASSEMBLY
14	1935255SM	1	NUT, Speed, 5/16-18
15	1960720SM	5	SCREW, #10-16 x 1/2
16	1708536YP	1	CLUTCH, Electric
17	1709055SM	1	SEAL, Air Inlet
18	1708537SM	1	SLEEVE, Clutch Anchor
19	1918199SM	1	LOCKWASHER, 7/16
20	1960370SM	1	CAPSCREW, 7/16-20 x 2-12
21	1933263SM	2	WASHER, Flat, 7/16
22	1708405SM	1	VALVE, Shut Off
23	1722955SM	1	THROTTLE CONTROL, Single
24	1726418ASM	1	DUCT, Top, R.H.
25	1722621ASM	1	DUCT, Bottom
34	2827187SM	2	CAPSCREW, Taptite, 3/8-16 x 1
35	2828635SM	2	CAPSCREW, Taptite, 3/8-16 x 1-1/4

### Footnotes

Note\* See your local Briggs & Stratton distributor for parts and service.

---

**The above parts group applies to the following Mfg. Nos.:**

2690802 - Coronet

# Transmission Group - Hydro-Gear 340-0510

986402

NOTE: Unless noted otherwise,  
use the standard hardware torque  
specification chart.

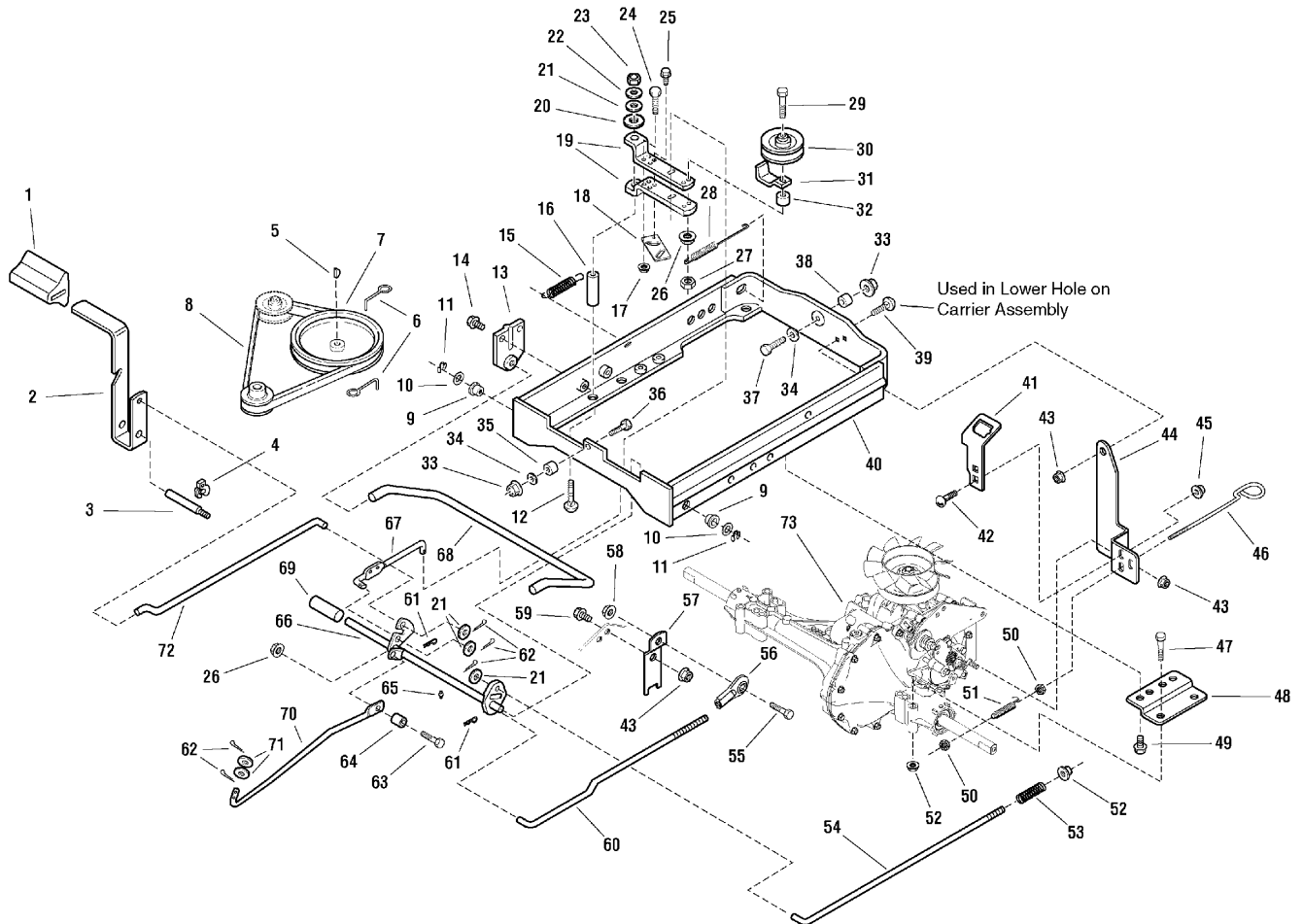

## The above parts group applies to the following Mfg. Nos.:

- 1694462 - Coronet
- 1694463 - Coronet
- 1694464 - 2413H
- 1694510 - Coronet
- 1694536 - 2413
- 2690800 - Coronet
- 2690802 - Coronet

## Transmission Group - Hydro-Gear 340-0510

REF NO	PART NO.	QTY.	DESCRIPTION
1	1704849SM	1	PAD, Brake
2	1723348ASM	1	LEVER, Clutch
3	1708409SM	1	PIVOT, Brake
4	1708554SM	1	RING, Klipping Extension
5	2171241SM	1	KEY, Hi-Pro
6	1704419SM	2	STOP, Belt
7	1723497SM	1	PULLEY & HUB ASSEMBLY, Engine
8	1707346SM	1	V - BELT
9	1715025SM	2	BUSHING
10	1924361SM	2	WASHER, 1/2
11	1703805SM	1	RING, Klipping Extension
12	1931342SM	1	CARRIAGE BOLT, 5/16 - 18 x 2-1/4 G5
13	1708367SM	2	BRACKET, Torsion Bar
14	1924856SM	4	SCREW, Hex, Washer Head, Taptite, 5/16 - 18 x 1/2
15	2159106SM	1	SPRING, Extension
16	1709345SM	1	SPACER
17	1930641SM	1	NUT, Hex, Flange, 1/4 - 20, Whiz Lock LG
18	1725839ASM	1	PLATE, Idler 10GA
19	1709221SM	2	CLEVIS HALF
20	1924366SM	1	WASHER, 5/8
21	1919326SM	5	WASHER, 5/16
22	1917356SM	1	LOCKWASHER, Spring 5/16
23	1917372SM	1	NUT, Hex 5/16 - 18
24	1923341SM	1	CAPSCREW, Hex Head, 1/4 - 20 x 3/4 G5
25	1927429SM	1	SCREW, Hex, Washer Head, Taptite, 1/4 - 20 x 5/8
26	1928352SM	2	NUT, Hex Flange,, 3/8 - 16 Whiz Lock LG
27	1928731SM	1	NUT, Hex, Toplock, Jam, 3/8 - 16
28	1725250SM	1	SPRING, Extension
29	1922918SM	1	CAPSCREW, Hex Head, 3/8 - 16 x 3-1/4 G5
30	1668827SM	1	PULLEY
31	1708352ASM	1	GUARD, Spring
32	1725838SM	1	SPACER
33	1930644SM	1	NUT, 1/2 - 13, Two-Way Lock
34	1924361SM	1	WASHER, 1/2
35	1719683SM	1	SPACER
36	1921176SM	1	CAPSCREW, Hex Head, 1/2 - 20 x 1-1/4 G5
37	1923114SM	1	CAPSCREW, Hex Head, 1/2 - 13 x 1 G5
38	1719725SM	1	SPACER
39	1931332SM	1	CARRIAGE BOLT, 5/16 - 18 x 5/8 G5
40	1687051SM	1	CARRIER ASSEMBLY
41	1726554ASM	1	BRACKET, Switch Mounting (No-Mow Models Only)
42	1931317SM	2	CARRIAGE BOLT, 1/4 - 20 x 3/4, G5 (No-Mow Models Only)
43	1931277SM	3	NUT, Hex Flange, 5/16 - 18, Whiz Lock Small
44	1726555ASM	1	STRAP, Torque (No-Mow Models Only)

### Footnotes

---

#### The above parts group applies to the following Mfg. Nos.:

1694462 - Coronet      2690802 - Coronet  
1694463 - Coronet  
1694464 - 2413H  
1694510 - Coronet  
1694536 - 2413  
2690800 - Coronet

# Transmission Group - Hydro-Gear 340-0510

986402

**NOTE:** Unless noted otherwise,  
use the standard hardware torque  
specification chart.

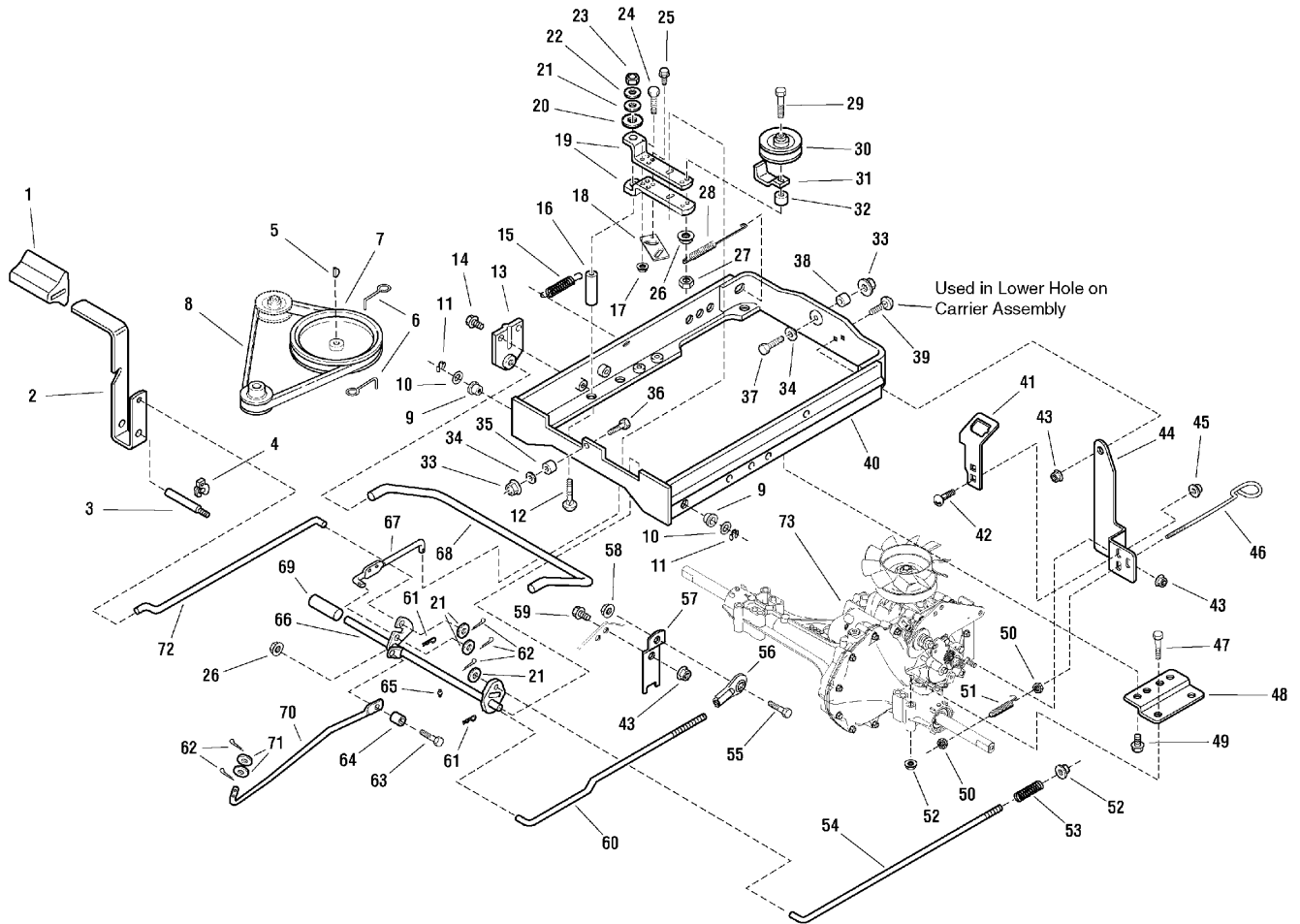

**The above parts group applies to the following Mfg. Nos.:**

- 1694462 - Coronet      2690802 - Coronet
- 1694463 - Coronet
- 1694464 - 2413H
- 1694510 - Coronet
- 1694536 - 2413
- 2690800 - Coronet



## Transmission Group - Hydro-Gear 340-0510

REF NO	PART NO.	QTY.	DESCRIPTION
44	1726555ASM	1	STRAP, Torque
45	1960694SM	2	NUT, Hex Flange, 1/4 - 20 ESNA (No-Mow Models Only)
46	1733995SM	1	ROD, Bypass
47	1921719SM	4	CAPSCREW, Hex Head, 5/16 - 18 x 2-1/2 G5
48	1725706ASM	2	BRACKET, Mounting
49	1664847SM	4	SCREW, Hex, Washer Head, Taptite, 5/16 - 18 x 3/4
50	1916621SM	2	NUT, Hex Machine Screw
51	1726327SM	1	SPRING, Extension
52	1935048SM	5	NUT, Hex Flange, 5/16 - 18, Two-Way Lock
53	1708360SM	1	SPRING
54	1725166SM	1	ROD, Brake
55	1921210SM	1	CAPSCREW, Hex Head, 3/8 - 16 x 1 G5
56	1726559SM	1	ROD, End
57	1725736ASM	1	LEVER, Control
58	1930645SM	1	NUT, Hex Flange, 3/8 - 16, Two-Way Lock
59	1925205SM	1	CAPSCREW, Hex Head, 5/16 - 18 x 5/8 G5
60	1725167SM	1	ROD, Control
61	1722460SM	2	PIN, Quick
62	1918447SM	6	PIN, Cotter
63	2860709SM	1	SCREW, Hex, Whiz Lock, Flange, 3/8 - 16 x 1-3/4
64	1666804SM	1	SPACER
65	2821133SM	1	FITTING, Lube, 1/4 Drive
66	1725768SM	1	SHAFT & ARMS ASSEMBLY, Pivot
67	1709220SM	1	CLUTCH, Rear
68	1708366SM	1	BAR, Torsion
69	1709850SM	1	TUBE
70	1725767SM	1	ROD, Shift, Front
71	1924359SM	2	WASHER, 1/2
72	1706260SM	1	ROD, Clutch, Front
73	1725620SM	1	TRANSMISSION ASSEMBLY, Hydro Gear

### Footnotes

---

**The above parts group applies to the following Mfg. Nos.:**

1694462 - Coronet      2690802 - Coronet  
1694463 - Coronet  
1694464 - 2413H  
1694510 - Coronet  
1694536 - 2413  
2690800 - Coronet

# Transmission SERVICE PARTS - Hydro-Gear 340-0510

1725620

**NOTE: Unless noted otherwise,  
use the standard hardware torque  
specification chart.**

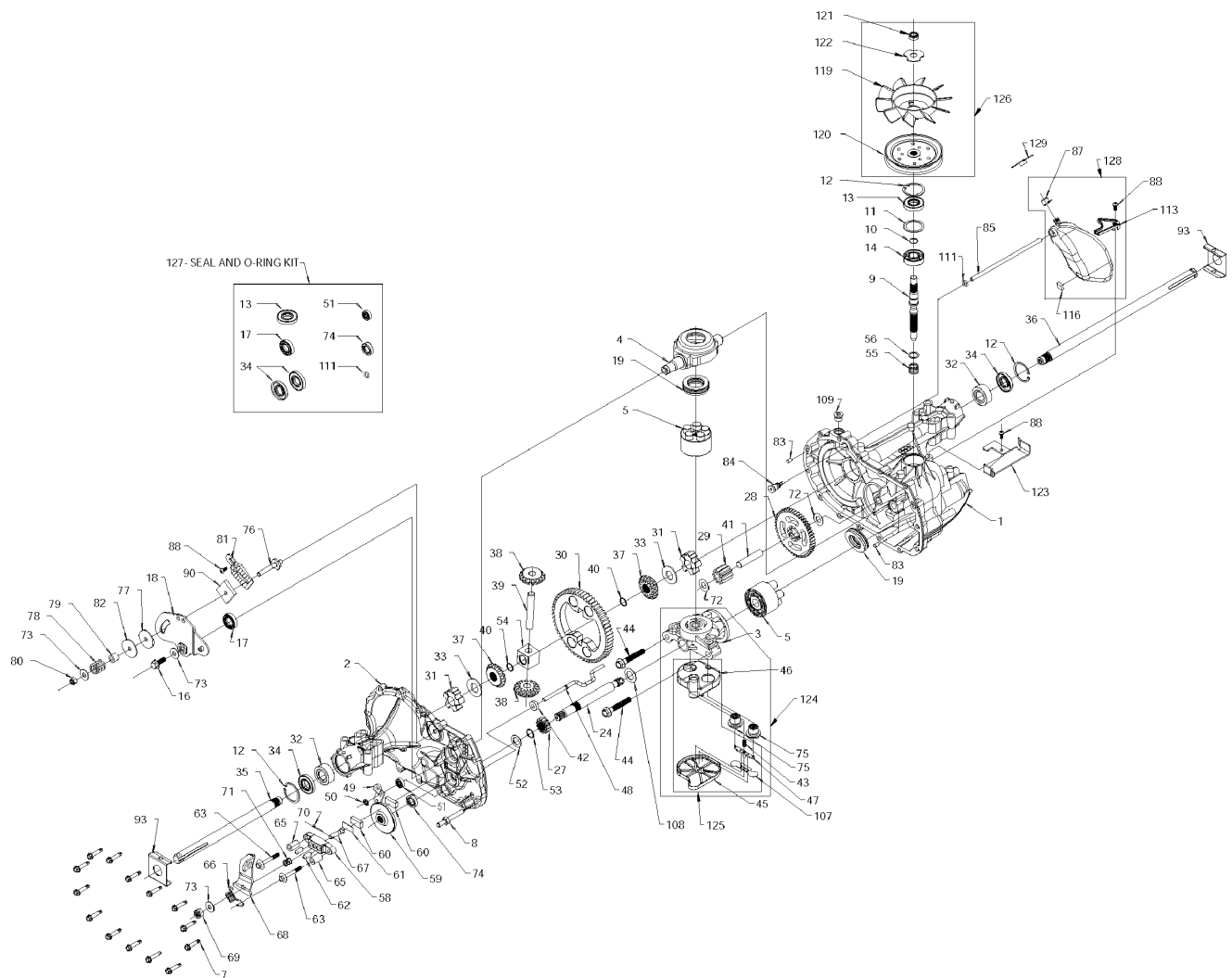

**The above parts group applies to the following Mfg. Nos.:**

- 1694462 - Coronet      2690802 - Coronet
- 1694463 - Coronet
- 1694464 - 2413H
- 1694510 - Coronet
- 1694536 - 2413
- 2690800 - Coronet

## Transmission SERVICE PARTS - Hydro-Gear 340-0510

REF NO	PART NO.	QTY.	DESCRIPTION
1	*	1	MAIN HOUSING, ASSEMBLY
2	*	1	SIDE HOUSING, ASSEMBLY
3	*	1	CENTER SECTION, ASSEMBLY
4	*	1	SWASHPLATE, TRUNNION MACHINED
5	*	2	BLOCK - ASSEMBLY
6	*	10.5	SEALANT (Not Shown)
7	1730269SM	14	HEX FLANGE SCREW 1/4-20 X 1.25
8	1730270SM	1	STUD, 5/16-24 HEX DOUBLE END
9	1730271SM	1	SHAFT, INPUT
10	1715270SM	1	RING - RETAINING
11	1730272SM	1	SPACER
12	1730273SM	1	RING - RETAINING
13	**	1	SEAL, LIP .67 X 1.58 X .276
14	1730274SM	1	BALL BRG 17MM ID X 40MM OD X 12MM
16	1730275SM	1	HEX FLANGE HEAD SCREW 5/16-24 X 0.75
17	**	1	LIP SEAL 18 X 32 X 7
18	1730276SM	1	ARM, CONTROL
19	*	1	BEARING, 30X52X13 THRUST
24	*	1	SHAFT, MOTOR
27	*	1	GEAR - PINNION, 13T
28	*	1	10T/48T GEAR
29	*	1	GEAR, 10T JACKSHAFT
30	*	1	60T BULL GEAR
31	*	2	SLEEVE BEARING .75 X 1.750 X .625
32	1730277SM	2	SLEEVE BEARING (OUTBOARD) .75 X 1.575 X .625
33	*	2	WASHER, 3/4 ID X 1-1/2 OD X .13 THK
34	**	2	LIP SEAL AXLE SEAL
35	1730278SM	1	SHAFT, AXLE .75 x 11.39 (KEY, R.H.)
36	1730279SM	1	SHAFT, AXLE .75 X 16.99 (KEY, L.H.)
37	*	2	MITER GEAR (SPLINED)
38	*	2	MITER GEAR 15T (0.5 ID)
39	*	1	SHAFT
40	*	2	RING, SPIRAL RETAINING
41	*	1	PIN, JACKSHAFT
42	*	1	MAGNET, RING
43	*	1	SPRING, BYPASS
44	*	2	BOLT, HEX FLANGE 3/8-24 X 2.5
45	*	1	BOTTOM, FILTER
46	*	1	BASE, FILTER W/POPPET
47	*	1	ACTUATOR, BYPASS
48	*	1	ROD, BYPASS ACTUATOR
49	1730280SM	1	ARM, BYPASS
50	1730281SM	1	RETAINING RING .250 EXTERNAL
51	**	1	SEAL, LIP .741 X .250 x .250 TC

### Footnotes

Note\* Not serviced seperately, order complete transmission.

Note\* Not serviced seperately, order complete transmission.

### The above parts group applies to the following Mfg. Nos.:

1694462 - Coronet      2690802 - Coronet  
 1694463 - Coronet  
 1694464 - 2413H  
 1694510 - Coronet  
 1694536 - 2413  
 2690800 - Coronet

# Transmission SERVICE PARTS - Hydro-Gear 340-0510

**NOTE: Unless noted otherwise,  
use the standard hardware torque  
specification chart.**

1725620

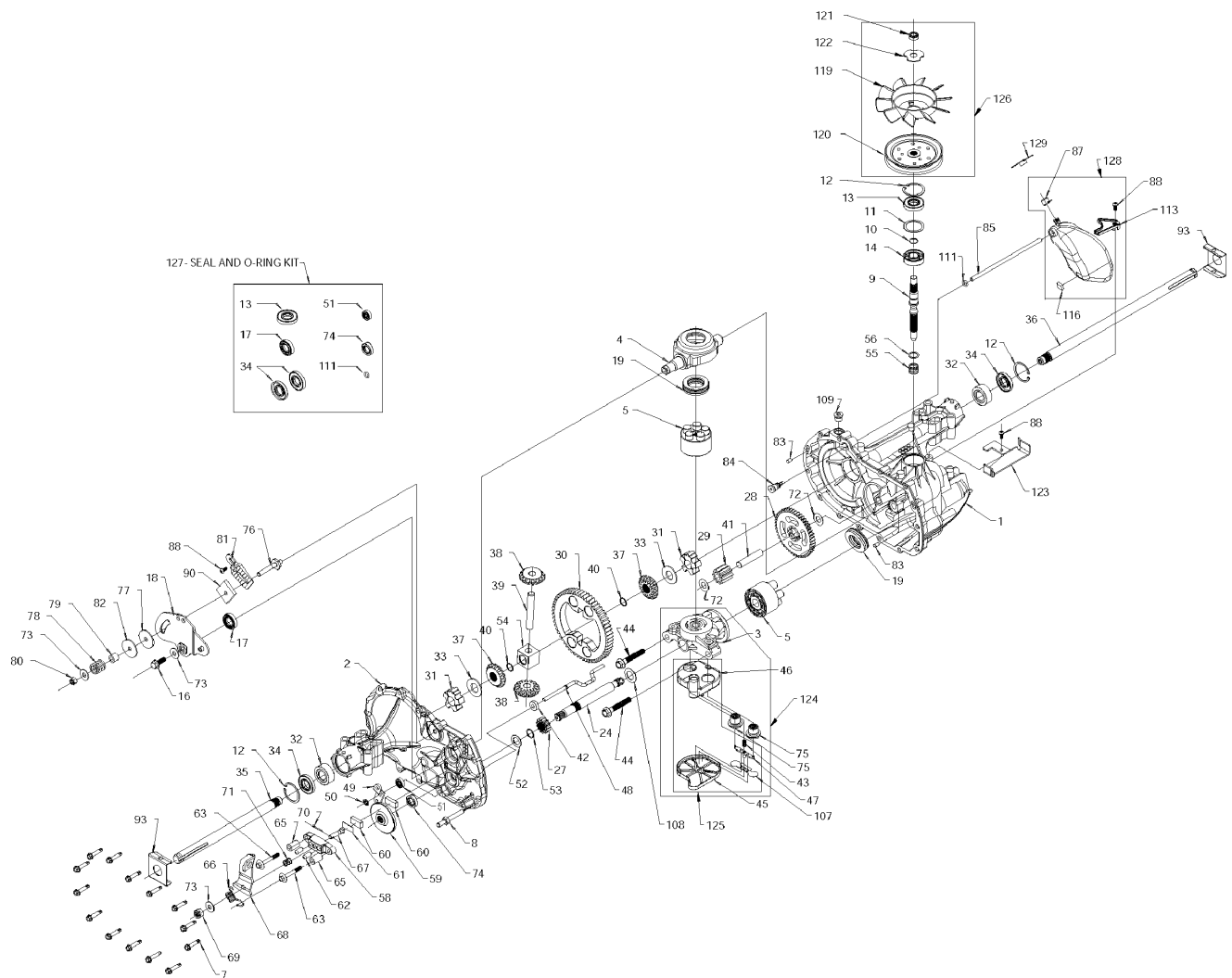

**The above parts group applies to the following Mfg. Nos.:**

- 1694462 - Coronet      2690802 - Coronet
- 1694463 - Coronet
- 1694464 - 2413H
- 1694510 - Coronet
- 1694536 - 2413
- 2690800 - Coronet

## Transmission SERVICE PARTS - Hydro-Gear 340-0510

REF NO	PART NO.	QTY.	DESCRIPTION
52	*	1	FLAT WASHER, 5/8 ID X 1.0 OD X .05 THK
53	*	1	RETAINING RING
54	*	1	BEARING, CENTER BLOCK
55	1715171SM	1	SPRING - HELICAL COMPRESSION
56	1715172SM	1	WASHER
57		78.8	20W-50 OIL (Not Shown)
58	1730282SM	1	BRAKE YOKE
59	1730283SM	1	ROTOR, BRAKE
60	1706146SM	2	BRAKE PUCK
61	1706145SM	1	PUCK PLATE
62	1706141SM	2	BRAKE ACTUATING PIN
63	1730284SM	2	HFHCS 1/4-20 X 2 W/PATCH
65	1715199SM	2	SPACER
66	1730285SM	1	SPRING, BRAKE ARM BIAS
67	1706160SM	1	SQ.HD.BOLT 5/16-24- RIBBED
68	1730286	1	ARM, BRAKE
69	1714431SM	1	SLOTTED HEX NUT 5/16-24
70	1730287	1	COTTER PIN 3/32 X 3/4
71	1730288	1	SPRING, COMPRESSION
72	*	2	WASHER, HT .5 X 1 X .032
73	1730289	3	FLAT - WASHER 11/32 I.D. X 7/8 O.D
74	**	1	OIL SEAL .625 X 1.0 X.25
75	*	2	CHECK PLUG ASSEMBLY, .027, WASHER
76	1714741SM	1	STUD, 5/16-24 FRICTION PACK
77	1730290	1	PUCK, .330 X 1.50 X .0975
78	1714739SM	1	SPRING, HELICAL COMP
79	1714740SM	1	SPACER
80	1715178SM	1	HEX LOCK NUT 5/16-24 UNJF
81	1730291	1	WEDGE, FRICTION PACK
82	1730292	1	WASHER .316 X 1.50 X .1046 (PLATED)
83	*	2	PIN, STANDARD HEADLESS
84	*	1	FITTING, 5/16 SAE 5/32 TUBE
85	1730293	1	HOSE, EXPANSION TANK
87	1730294	1	CAP, VENT
88	1714742SM	3	BOLT, SELF TAPPING 10-32 X 1/2
90	1730295	1	PUCK, INNER WEDGE
93	1730296	2	SPRING CLIP - HOUSING THRUST
107	*	1	DEFLECTOR
108	*	1	WASHER, .71 X 1.16 X .030 THK
109	1730297	1	PLUG, SAE #6
111	**	1	O-RING .07 X .301 ID
113	1730298	1	BRACKET,SUPPORT EXPANSION TANK
116	1730299	1	SILICON SPONGE
119	1730300SM	1	FAN 6" 10 BLADE
120	1730301	1	PULLEY 3.86

### Footnotes

Note\* Not serviced seperately, order complete transmission.

Note\* Not serviced seperately, order complete transmission.

### The above parts group applies to the following Mfg. Nos.:

1694462 - Coronet      2690802 - Coronet  
 1694463 - Coronet  
 1694464 - 2413H  
 1694510 - Coronet  
 1694536 - 2413  
 2690800 - Coronet

# Transmission SERVICE PARTS - Hydro-Gear 340-0510

**NOTE: Unless noted otherwise,  
use the standard hardware torque  
specification chart.**

1725620

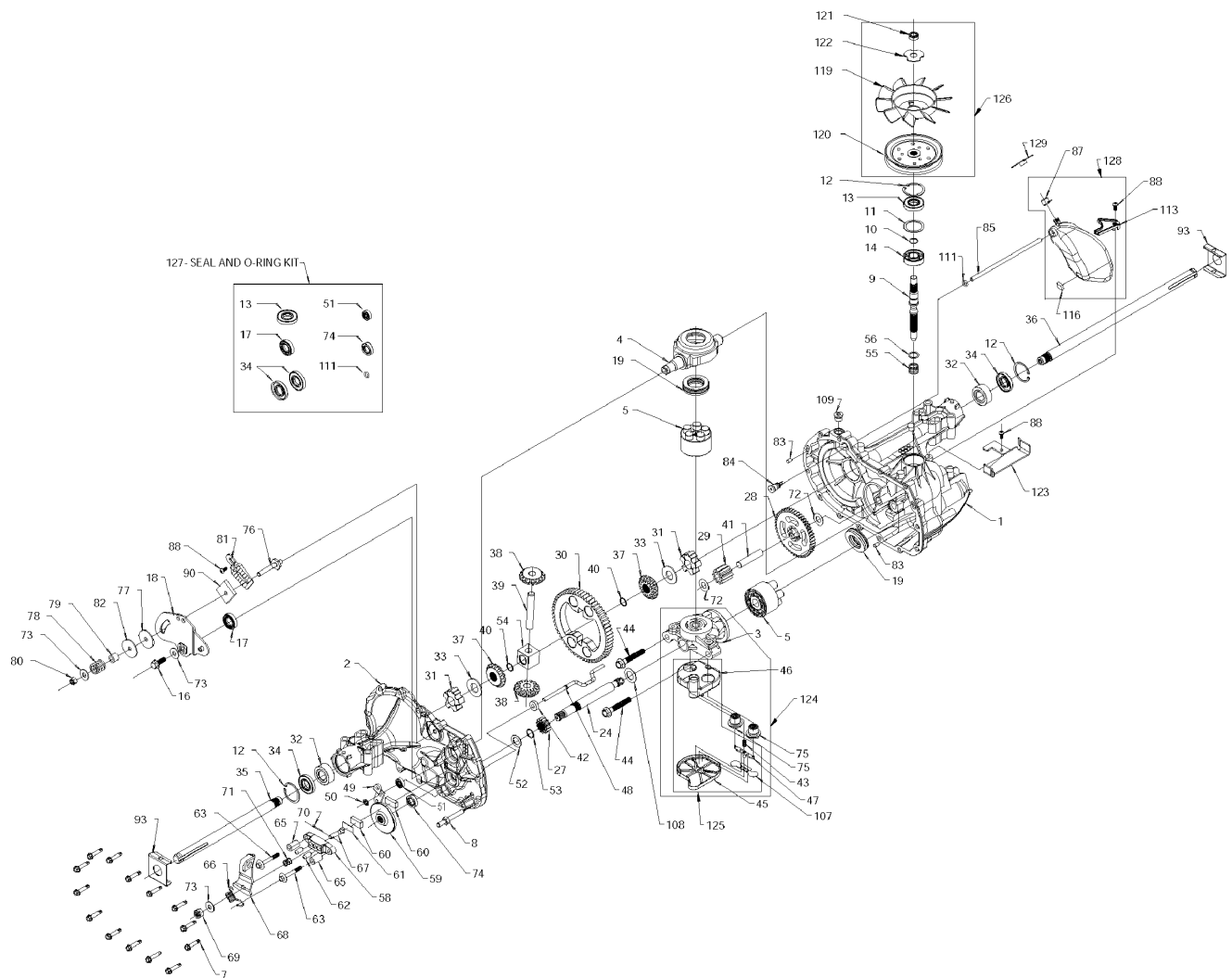

**The above parts group applies to the following Mfg. Nos.:**

- 1694462 - Coronet      2690802 - Coronet
- 1694463 - Coronet
- 1694464 - 2413H
- 1694510 - Coronet
- 1694536 - 2413
- 2690800 - Coronet

## **Transmission SERVICE PARTS - Hydro-Gear 340-0510**

---

<b>REF NO</b>	<b>PART NO.</b>	<b>QTY.</b>	<b>DESCRIPTION</b>
121	1730302	1	NUT, HEX LOCK 1/2-20 (NYLON INSERT)
122	1730303	1	WASHER, OD SLOTTED .53 X 1.63 X .06
123	1730304	1	BELT KEEPER
124	*	1	CENTER SECTION - FILTER - BYPASS ASSEMBLY (Incl Ref No 3, 43, 45, 46, 47, 75 & 107)
125	*	1	FILTER ASSEMBLY (Incl Ref No 43, 45, 46, 47 & 107)
126	1730305	1	KIT, FAN/PULLEY (Incl Ref No 13, 17, 34, 51, 74 & 111)
127	1730306	1	SEAL - O-RING KIT (Incl Ref No 13, 17, 34, 51, 74 & 111)
128	1730307SM	1	KIT, EXPANSION TANK (Incl Ref No 87, 88, 113 & 116)
129	1730308	1	CAP, EXPANSION TANK SHIPPING

### **Footnotes**

Note\* Not serviced seperately, order complete transmission.

Note\* Not serviced seperately, order complete transmission.

---

### **The above parts group applies to the following Mfg. Nos.:**

1694462 - Coronet      2690802 - Coronet

1694463 - Coronet

1694464 - 2413H

1694510 - Coronet

1694536 - 2413

2690800 - Coronet

# Electrical Group

985431

NOTE: Unless noted otherwise,  
use the standard hardware torque  
specification chart.

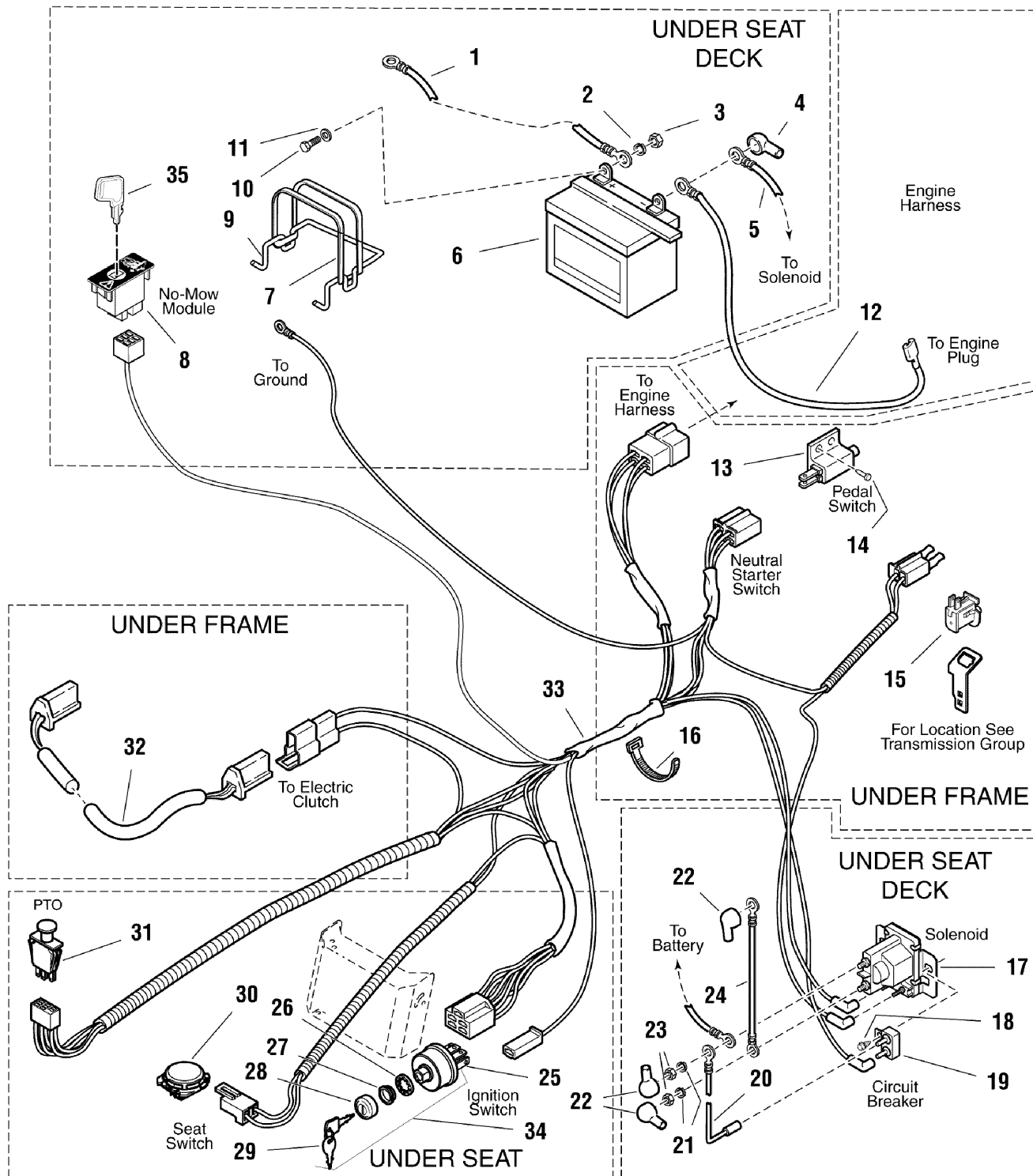

The above parts group applies to the following Mfg. Nos.:

- 1694463 - Coronet
- 1694464 - 2413H



## Electrical Group

REF NO	PART NO.	QTY.	DESCRIPTION
1	1733112SM	1	CABLE, Battery to Ground
2	2816964SM	2	WASHER, Lock, 1/4
3	2816622SM	2	NUT, Hex 1/4-20
4	1709086SM	1	BOOT, Insulator
5	1727668SM	1	CABLE, Battery to Solenoid
6	1685215SM	1	BATTERY
7	1665872SM	1	STRAP, Battery
8	1726556SM	1	SWITCH, RMO Module Only
9	1667805SM	1	BRACE, Battery
10	2823341SM	2	CAPSCREW, Hex Head, 1/4-20 x 3/4
11	2821319SM	2	WASHER
12	1718952SM	1	WIRE ASSEMBLY, 16GA
13	1717050SM	1	SWITCH, Neutral Start
14	1722035SM	2	POP-RIVET
15	1732004SM	1	SWITCH, Push Button (N.O.) (RMO Models Only)
16	1701011SM	2	TIE, Self-Locking
17	1686981SM	1	SOLENOID
18	1925003SM	2	CAPSCREW, Hex Head, Taptite, 1/4-20 x 1/2
19	1665238SM	1	CIRCUIT BREAKER
20	1665237SM	1	WIRE ASSEMBLY
21	1917356SM	1	LOCKWASHER, 5/16
22	2122023SM	3	COVER, Terminal
23	2820263SM	2	NUT, Hex, 5/16-24
24	1709088SM	1	CABLE, Solenoid to Starter
25	**	1	SWITCH, Ignition (6 pole)
26	1960547SM	1	WASHER, Internal Tooth, 5/8
27	1717549SM	1	NUT
28	1717550SM	1	COVER, Keyswitch
29	1717163SM	1	KEYS (Set of 2 Keys)
30	1718981SM	1	SWITCH, Seat
31	1722887SM	1	* SWITCH, PTO, Electric Clutch
32	1726667SM	1	WIRE HARNESS, Clutch (RMO Models Only)
32	1724873SM	1	WIRE HARNESS, Clutch
33	1726654SM	1	HARNESS, Wiring (RMO Models Only)
33	1718946SM	1	HARNESS, Wiring
34	1686734SM	1	IGNITION KEY SWITCH ASSEMBLY
35	1726557SM	1	KEY, RMO Module, Plastic

### Footnotes

Note\* If connection blades do not line up use 1686620 Switch Kit. (Contains switch, adaptor & instruction sheet.)

Note\*\* See reference number 41. Sold as assembly.

---

### The above parts group applies to the following Mfg. Nos.:

1694463 - Coronet

1694464 - 2413H

# Electrical Group

986569

**NOTE:** Unless noted otherwise, use the standard hardware torque specification chart.

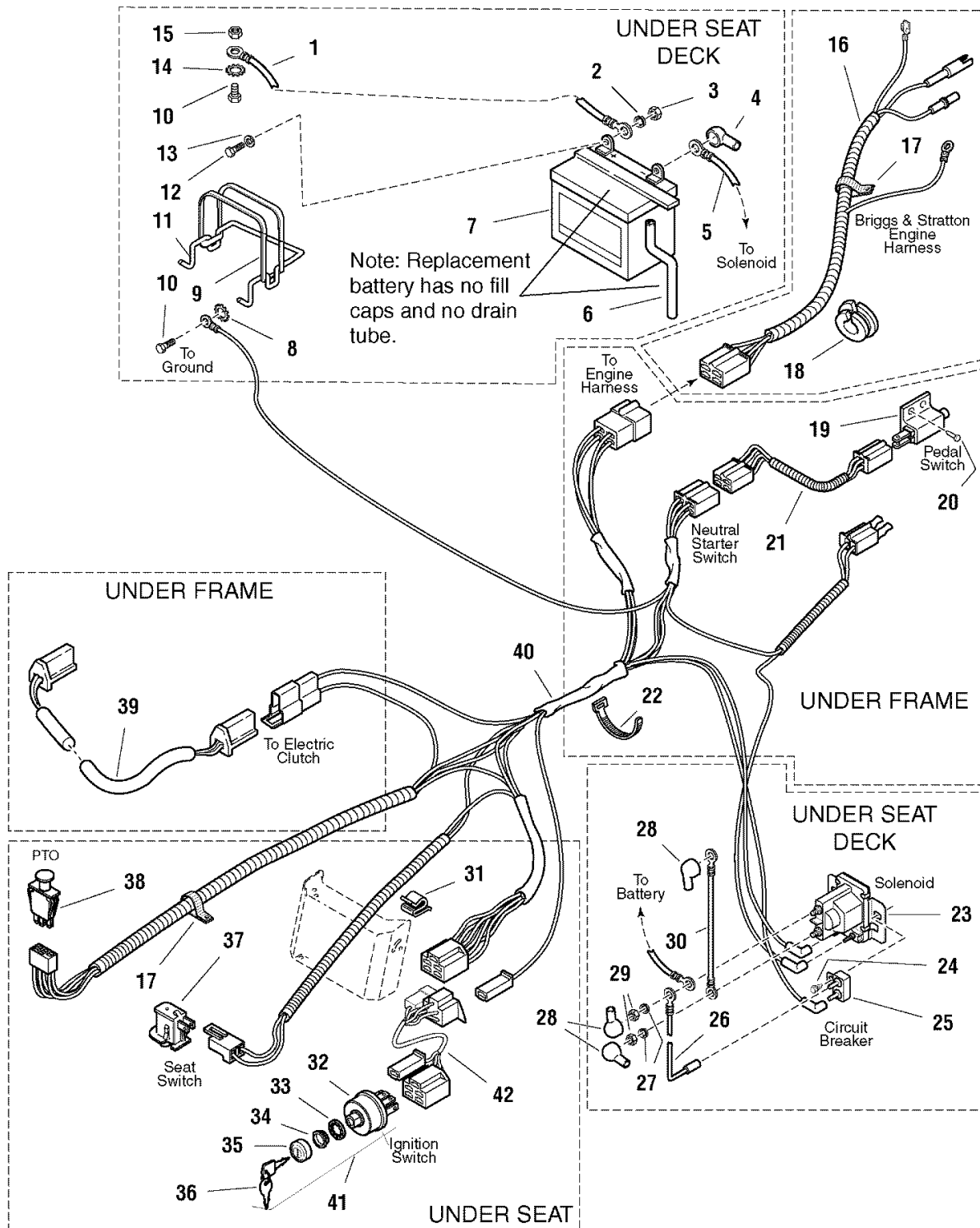

**The above parts group applies to the following Mfg. Nos.:**

- 1694462 - Coronet
- 1694510 - Coronet
- 1694536 - 2413

## Electrical Group

REF NO	PART NO.	QTY.	DESCRIPTION
1	1707056SM	1	CABLE, Battery to Ground
2	2816964SM	2	WASHER, Lock, 1/4
3	2816622SM	2	NUT, Hex 1/4-20
4	1709086SM	1	BOOT, Insulator
5	1707056SM	1	CABLE, Battery to Solenoid (Kohler Models)
5	1713163SM	1	CABLE, Battery to Solenoid (Briggs & Stratton Models)
5	1707056SM	1	CABLE, Battery to Solenoid (Briggs & Stratton Models) (2400 Series Models Only)
6	1612103SM	1	TUBE, Vent (Early Models Only)
7	1685215SM	1	BATTERY
8	2820426SM	1	WASHER, Lock, External Tooth, 5/16
9	1665872SM	1	STRAP, Battery
10	1950018SM	2	CAPSCREW, Metric, M08-1.25 x 20 mm
11	1667805SM	1	BRACE, Battery
12	2823341SM	2	CAPSCREW, Hex Head, 1/4-20 x 3/4
13	2821319SM	2	WASHER
14	2820427SM	1	WASHER, Lock, External Tooth, 3/8
15	2816950SM	1	NUT, Hex, 3/8-16
16	1718948SM	1	WIRE ASSEMBLY, Harness to Engine (Briggs & Stratton Only)
17	1704873SM	2	CLAMP, Wire (11 HP B&S 5-Speed Only)
18	1676648SM	1	GROMMET (11 HP 5-Speed Models Only)
19	1717050SM	1	SWITCH, Neutral Start
20	1722035SM	2	POP-RIVET
21	1718949SM	1	WIRE ASSEMBLY, Neutral Switch (11 HP Coronet Only)
22	1701011SM	2	TIE, Self-Locking
23	1686981SM	1	SOLENOID
24	1925003SM	2	CAPSCREW, Hex Head, Taptite, 1/4-20 x 1/2
25	1665238SM	1	CIRCUIT BREAKER
26	1665237SM	1	WIRE ASSEMBLY
27	1917356SM	1	LOCKWASHER, 5/16
28	2122023SM	3	COVER, Terminal
29	2820263SM	2	NUT, Hex, 5/16-24
30	1709088SM	1	CABLE, Solenoid to Starter
31	1715956SM	2 (1)	CLIP (14 HP Hydro Qty=1)
32	**	1	SWITCH, Ignition (6 pole)
33	1960547SM	1	WASHER, Internal Tooth, 5/8
34	1717549SM	1	NUT
35	1717550SM	1	COVER, Keyswitch
36	1717163SM	1	KEYS (Set of 2 Keys)
37	1718981SM	1	SWITCH, Seat
38	1722887SM	1	* SWITCH, PTO, Electric Clutch
38	1716332SM	1	* SWITCH, PTO, Electric Clutch (2400 Series Models Only)
39	1724873SM	1	WIRE ASSEMBLY, Clutch
40	1718946SM	1	HARNESS, Wiring
41	1686734SM	1	IGNITION KEY SWITCH ASSEMBLY

### Footnotes

Note\* If connection blades do not line up use 1686620 Switch Kit. (Contains switch, adaptor & instruction sheet.)

Note\*\* See reference number 41. Sold as assembly.

### The above parts group applies to the following Mfg. Nos.:

1694462 - Coronet  
 1694510 - Coronet  
 1694536 - 2413

# Electrical Group

986569

**NOTE:** Unless noted otherwise, use the standard hardware torque specification chart.

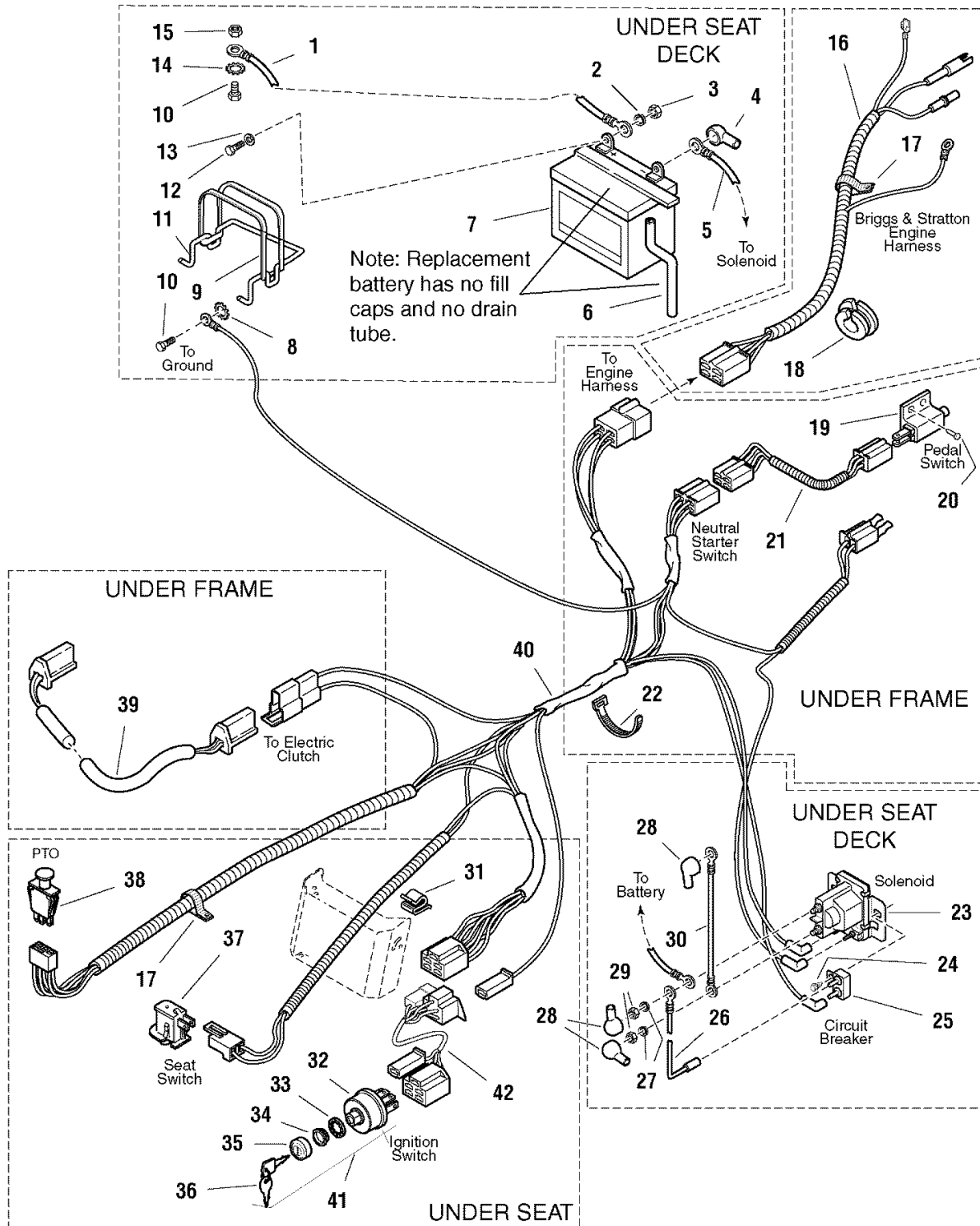

**The above parts group applies to the following Mfg. Nos.:**

- 1694462 - Coronet
- 1694510 - Coronet
- 1694536 - 2413

## ***Electrical Group***

---

<b>REF NO</b>	<b>PART NO.</b>	<b>QTY.</b>	<b>DESCRIPTION</b>
42	1726854SM	1	HARNESS, Wiring Extension (2400 Series Models Only)

---

### **Footnotes**

Note\* If connection blades do not line up use 1686620 Switch Kit. (Contains switch, adaptor & instruction sheet.)

Note\*\* See reference number 41. Sold as assembly.

---

### **The above parts group applies to the following Mfg. Nos.:**

1694462 - Coronet

1694510 - Coronet

1694536 - 2413

## Electrical Group

NOTE: Unless noted otherwise,  
use the standard hardware torque  
specification chart.

2988033

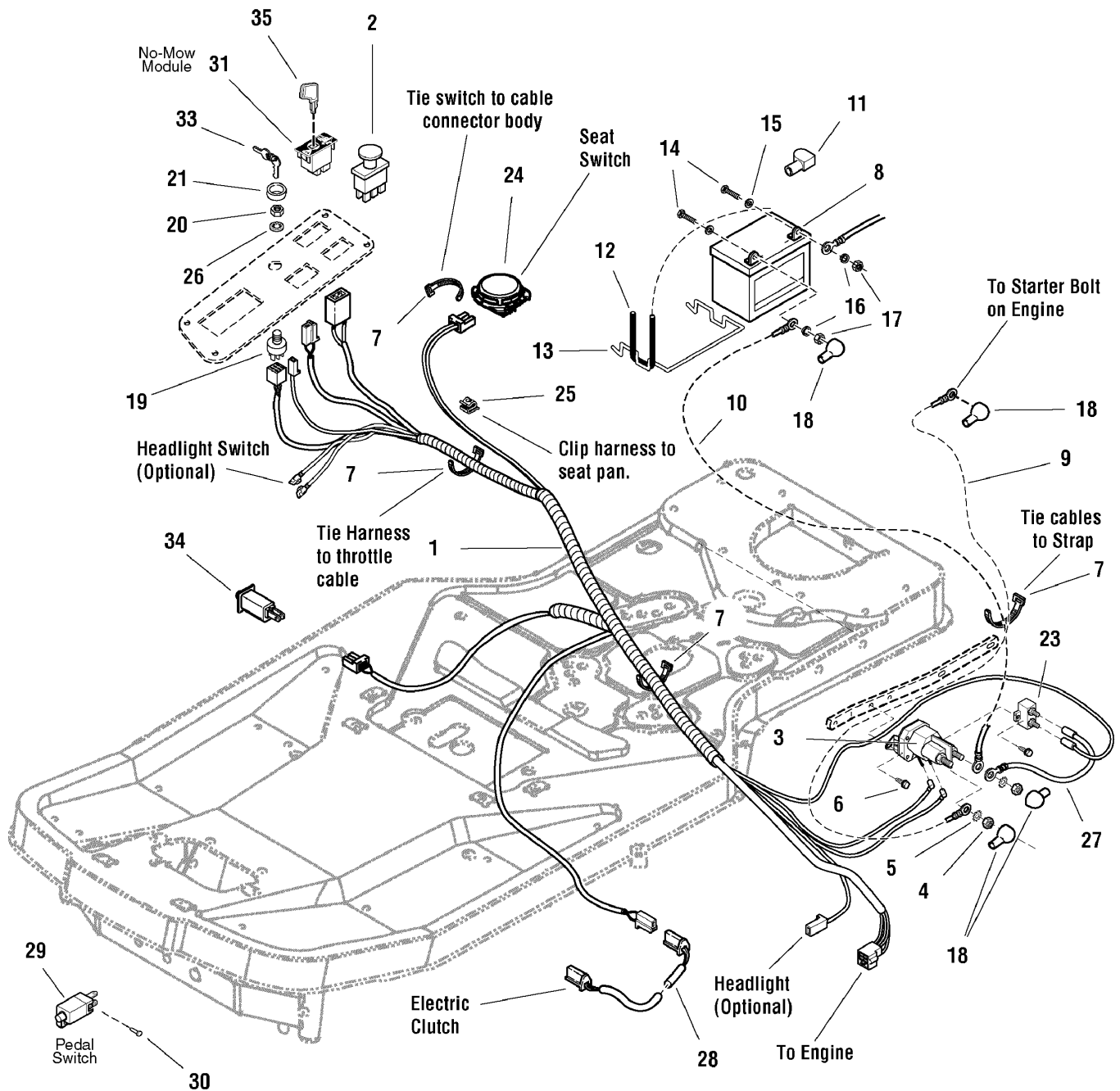

The above parts group applies to the following Mfg. Nos.:

2690800 - Coronet

2690802 - Coronet

## Electrical Group

REF NO	PART NO.	QTY.	DESCRIPTION
1	1736252YP	1	HARNESS, Wiring, Main
2	1722887SM	1	* SWITCH, PTO, Electric Clutch
3	1686981SM	1	SOLENOID, 4 Pole
4	2820263SM	2	NUT, Hex, 5/16-24
5	2820426SM	2	LOCKWASHER, 5/16
6	1925003SM	2	CAPSCREW, Hex Washer, Taptite, 1/4-20 x 1/2
7	1701011SM	2	TIE, Self-Locking
8	1685215SM	1	BATTERY
9	1709088SM	1	CABLE, Solenoid to Starter
10	1727668SM	3	CABLE, Battery to Solenoid, #6 x 15" Long
11	1677296SM	1	BOOT, Insulator
12	1665872SM	1	STRAP, Battery
13	1667805SM	1	BRACE, Battery
14	2823341SM	2	CAPSCREW, Hex Head, 1/4-20
15	2821319SM	2	WASHER, 1/4
16	2816964SM	2	LOCKWASHER, Spring, 1/4
17	2816622SM	2	NUT, Hex, 1/4-20
18	2122023SM	3	COVER, Terminal
19	1686734SM	1	IGNITION KEY SWITCH ASSEMBLY
20	1717549SM	1	NUT, Hex Flange, 5/8 x 32
21	1717550SM	1	COVER, Ignition Switch
23	1665238SM	1	CIRCUIT BREAKER
24	1714771SM	1	SWITCH, Seat
25	1715956SM	1	CLIP
26	1960547SM	1	LOCKWASHER, Internal Toot
27	1665237SM	1	WIRE ASSEMBLY
28	1726667SM	1	HARNESS, Main to Clutch
29	1717050SM	1	SWITCH, Neutral Start
30	1722035SM	2	RIVET, Pop
31	1726556SM	1	SWITCH, RMO Module Only
33	1727185SM	1	KEY, (Set of 2 Keys)
34	1704379SM	1	SWITCH, Push Button
35	1726557SM	1	KEY, RMO Module, Plastic

### Footnotes

Note\* If connection blades do not line up use 1686620 Switch Kit. (Contains switch, adaptor & instruction sheet.)

---

### The above parts group applies to the following Mfg. Nos.:

2690800 - Coronet  
2690802 - Coronet

# Front Column & Dash Group

984685

**NOTE:** Unless noted otherwise,  
use the standard hardware torque  
specification chart.

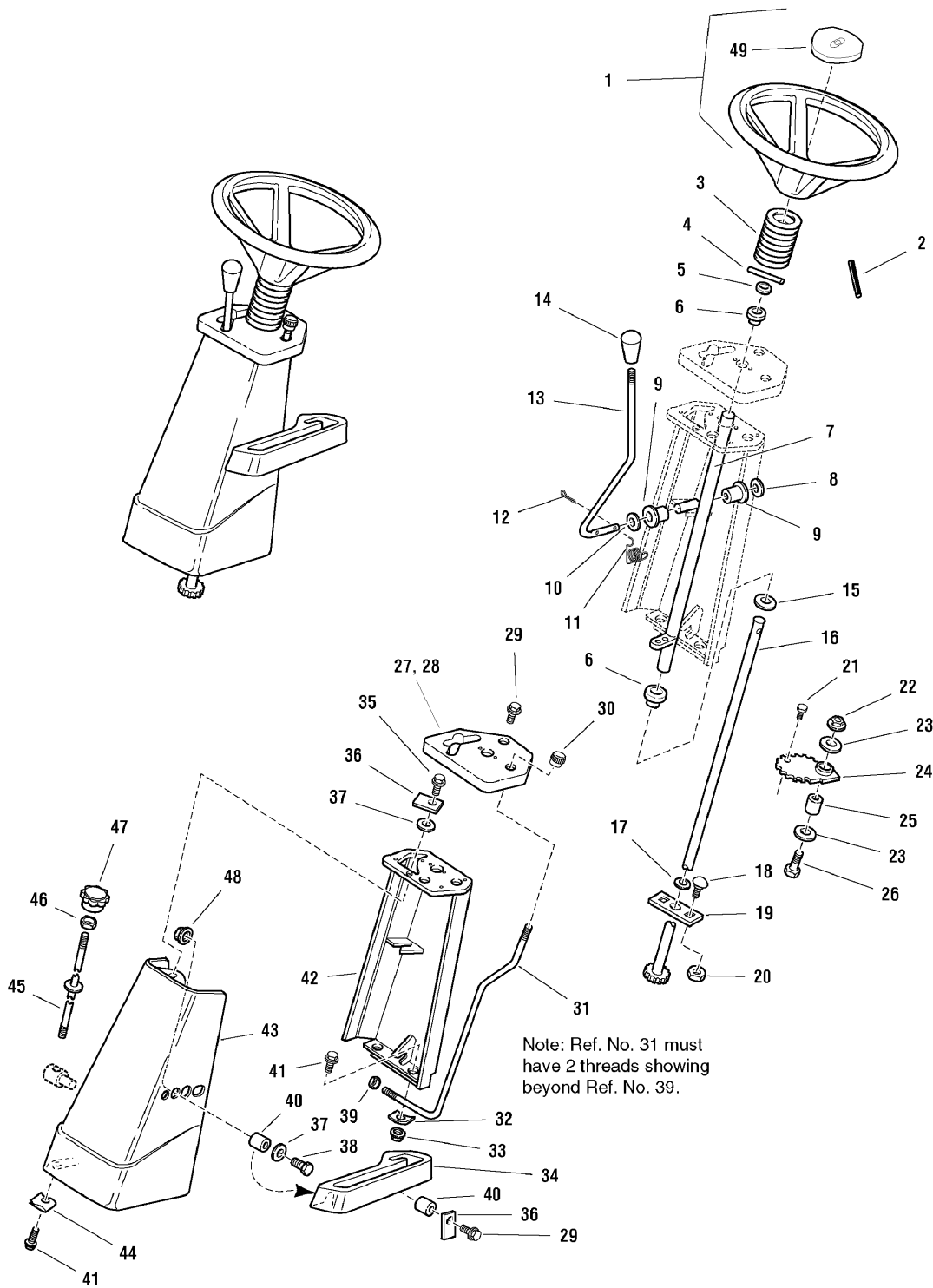

**The above parts group applies to the following Mfg. Nos.:**

- 1694462 - Coronet      2690802 - Coronet
- 1694463 - Coronet
- 1694464 - 2413H
- 1694510 - Coronet
- 1694536 - 2413
- 2690800 - Coronet



## Front Column & Dash Group

REF NO	PART NO.	QTY.	DESCRIPTION
1	1713841SM	1	STEERING WHEEL ASSEMBLY (Includes Ref. No. 49)
2	1960540SM	1	ROLL PIN
3	1678381SM	1	TUBE, Steering
4	2816001SM	1	PIN
5	1960160SM	3	WASHER, 49/64
6	2176440SM	2	BUSHING
7	1709229SM	1	TUBE ASSEMBLY, Shift
8	1960170SM	2	WASHER
9	1704428SM	2	BUSHING
10	1924361SM	1	WASHER, Plain, 17/32 x 1-1/4 x 7/64
11	1707424SM	1	SPRING, Torsion
12	1918447SM	2	COTTER PIN
13	1707375SM	1	ROD, Shift
14	1713843SM	1	KNOB, Rod, Shift
15	1960114SM	1	WASHER, Plain, 11/32 x 1 x 1/8
16	1706014SM	1	SHAFT ASSEMBLY, Steering
17	2173668SM	1	WASHER, Plain
18	1931350SM	2	CARRIAGE BOLT, 3/8-16 x 1
19	1703508ASM	1	PLATE, Steering Mounting
20	1928352SM	2	NUT, Hex, 3/8-16
21	1921221SM	1	CAPSCREW, Hex Head, 5/16-18 x 1-1/2
22	1960339SM	1	NUT, Hex, Flange Lock, 3/8-16
23	1924356SM	3	WASHER, 13/32 x 1-1/2 x 1/8
24	1708426SM	1	GEAR, Steering
25	1666332SM	1	SPACER
26	1923701SM	1	CAPSCREW, Hex Head, 3/8-16 x 2
27	1714081SM	1	DASH, Hydro
28	1714082SM	1	DASH, Gear
29	1925592SM	3	CAPSCREW, Hex, Flange, Taptite, 1/4-20 x 3/4
30	1713855SM	1	KNOB, Rod, Parking Brake
31	1707057SM	1	ROD, Parking Brake
32	1933988SM	2	PUSH NUT, 5/16
33	1931277SM	2	NUT, Hex, Flange, Whizlock, 5/16-18
34	1708965SM	1	QUADRANT, Lift
35	1925003SM	3	CAPSCREW, Hex Head, Taptite, 1/4-20 x 1/2
36	1709075SM	2	CLAMP
37	1921319SM	2	WASHER, Plain, 1/4
38	1924009SM	2	CAPSCREW, Hex Head, 1/4-20 x 7/8
39	1960608SM	1	NUT, Hex, Flange Centerlock, 1/4-20
40	1678392SM	3	SPACER, 17/64 x 3/8 x 21/64
41	1930591SM	6	CAPSCREW, Hex Head, Whizlock, 5/16-18 x 3/4
42	1708990ASM	1	SUPPORT, Steering
43	1708267CSM	1	SHROUD, Front (Orange)
43	1708267DSM	1	SHROUD, Front (Red)

### Footnotes

#### The above parts group applies to the following Mfg. Nos.:

1694462 - Coronet      2690802 - Coronet  
 1694463 - Coronet  
 1694464 - 2413H  
 1694510 - Coronet  
 1694536 - 2413  
 2690800 - Coronet

# Front Column & Dash Group

984685

**NOTE:** Unless noted otherwise,  
use the standard hardware torque  
specification chart.

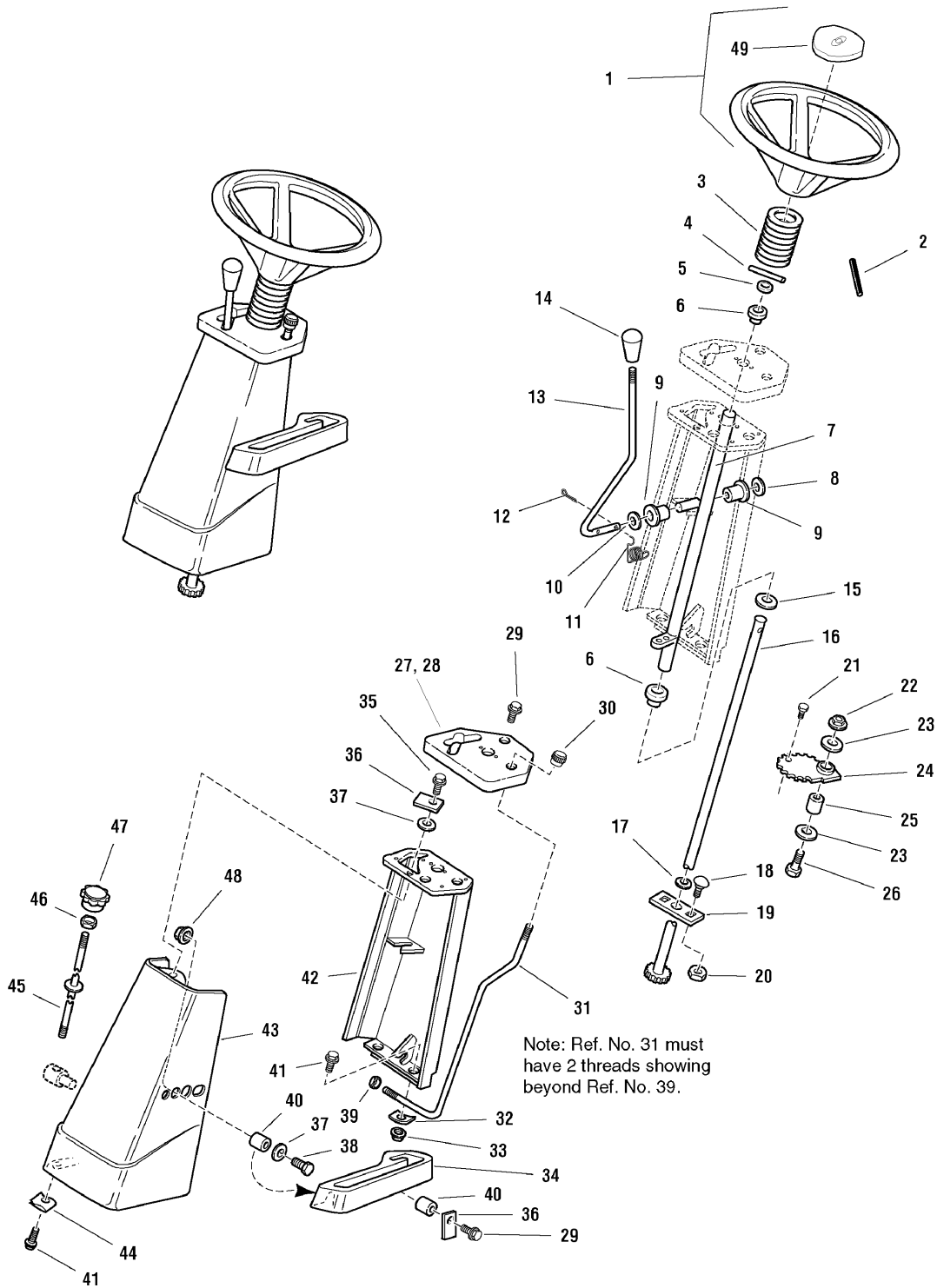

Note: Ref. No. 31 must  
have 2 threads showing  
beyond Ref. No. 39.

**The above parts group applies to the following Mfg. Nos.:**

- 1694462 - Coronet      2690802 - Coronet
- 1694463 - Coronet
- 1694464 - 2413H
- 1694510 - Coronet
- 1694536 - 2413
- 2690800 - Coronet

## Front Column & Dash Group

---

REF NO	PART NO.	QTY.	DESCRIPTION
44	1935255SM	4	PAL NUT, 5/16-18
45	1708971SM	1	ROD, Lift Height
46	1917421SM	2	NUT, Hex, Jam, 1/4-20
47	1713857SM	1	KNOB, Rod, Lift Height
48	1930641SM	2	NUT, Hex, Flange, Whizlock, 1/4-20
49	1714097SM	1	CAP

## Footnotes

---

### The above parts group applies to the following Mfg. Nos.:

1694462 - Coronet      2690802 - Coronet  
1694463 - Coronet  
1694464 - 2413H  
1694510 - Coronet  
1694536 - 2413  
2690800 - Coronet

## Wheels & Tires Group

W986490

NOTE: Unless noted otherwise,  
use the standard hardware torque  
specification chart.

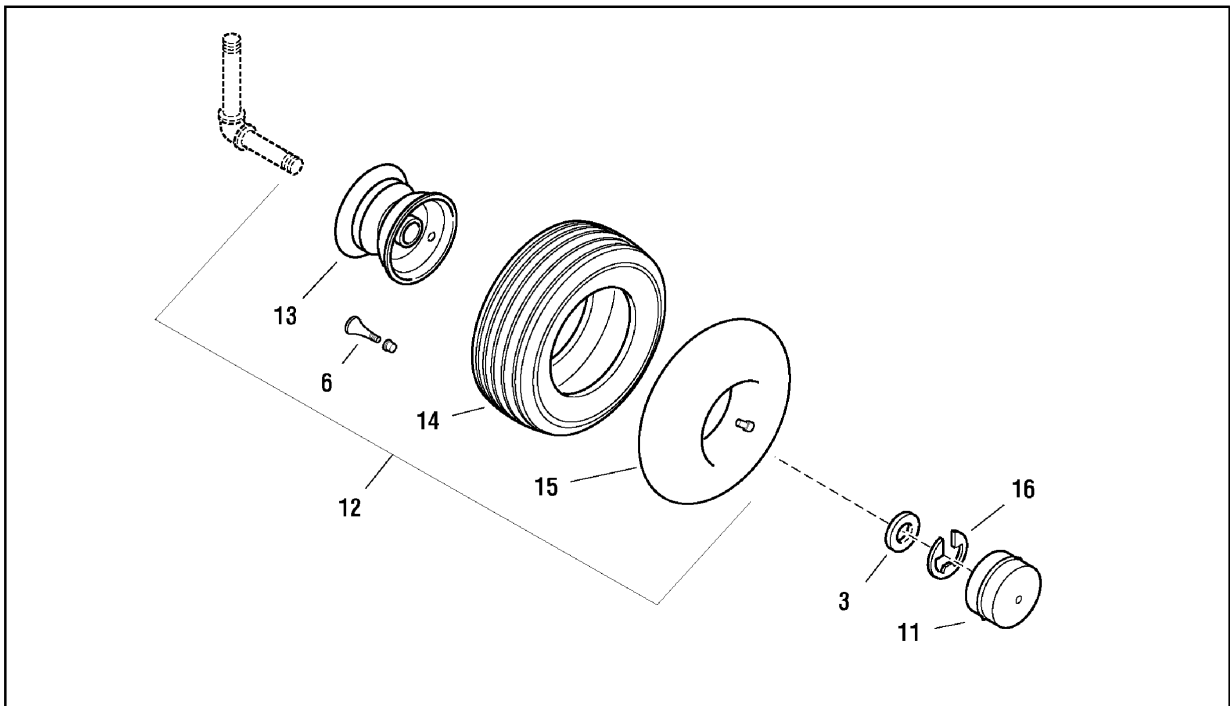
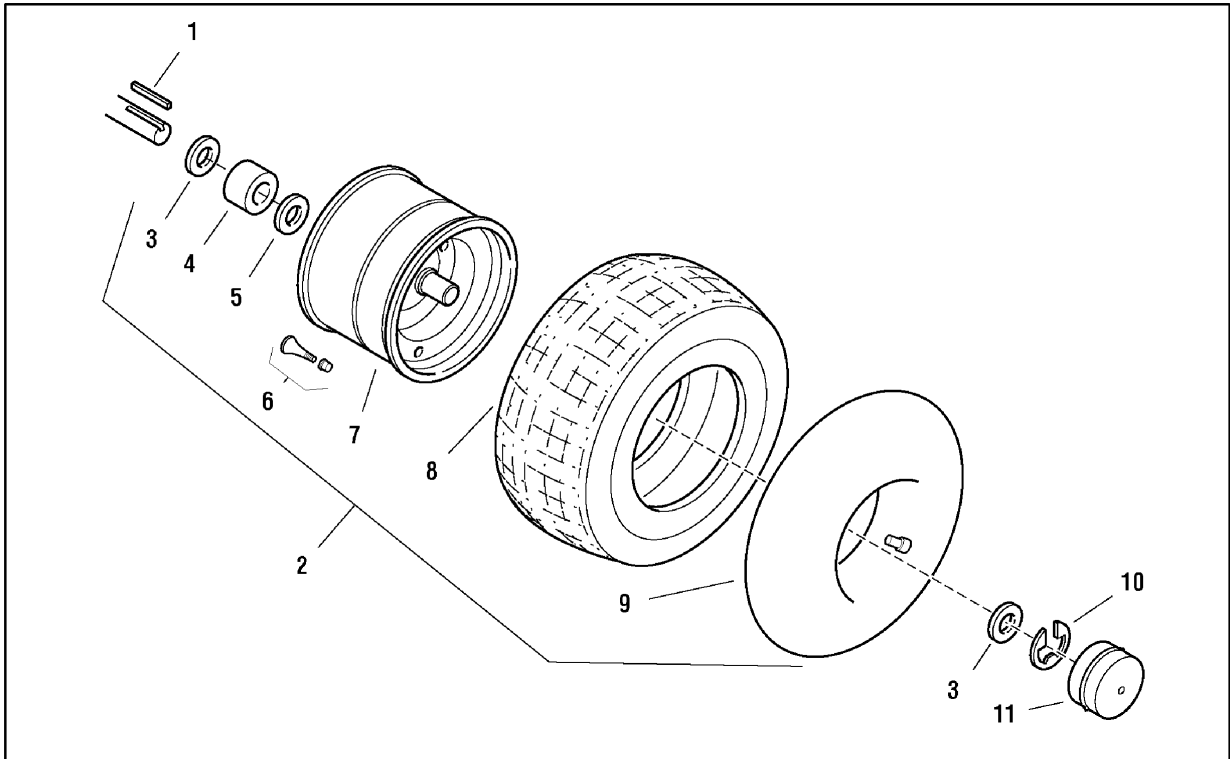

The above parts group applies to the following Mfg. Nos.:

1694462 - Coronet      2690802 - Coronet  
1694463 - Coronet  
1694464 - 2413H  
1694510 - Coronet  
1694536 - 2413  
2690800 - Coronet

## **Wheels & Tires Group**

<b>REF NO</b>	<b>PART NO.</b>	<b>QTY.</b>	<b>DESCRIPTION</b>
1	1729279SM	2	KEY, Square, 3/16 x 3/16 x 1-1/2 long
2	1723171SM	2	REAR WHEEL & TIRE ASSEMBLY, Hoosier, (Includes Ref. Nos. 3, 4, 7 & 8)
3	2860202SM	6	WASHER, 3/4
4	1717451SM	2	SPACER
5	1960114SM	2	WASHER
6	2172353SM	4	VALVE STEM & CAP
7	1723400SM	2	REAR WHEEL ASSEMBLY, Metallic Gray
8	1723399SM	2	TIRE, Rear Wheel, 16 X 6.50-8
9	2164247SM	2	TUBE, Rear Wheel
10	2827794SM	2	E RING
11	1722675SM	4	HUB CAP, Silver
12	1723170SM	2	FRONT WHEEL & TIRE ASSEMBLY, Hoosier, 13 x 5.00-6, Metallic Gray (Includes Ref. Nos. 4, 15, 18 & 19)
13	1723402SM	2	FRONT WHEEL ASSEMBLY 13 x 5.00-6, Metallic Gray (Includes Ref. No. 16)
14	1723401SM	2	TIRE, Front Wheel, 13 x 5.00-6
15	1664090SM	2	TUBE, Front Wheel, 4.10/3.50 x 6
16	1611710SM	2	KLIP RING

## **Footnotes**

---

### **The above parts group applies to the following Mfg. Nos.:**

1694462 - Coronet      2690802 - Coronet  
1694463 - Coronet  
1694464 - 2413H  
1694510 - Coronet  
1694536 - 2413  
2690800 - Coronet

## Decals Group - Brand & Model

NOTE: Unless noted otherwise,  
use the standard hardware torque  
specification chart.

B986490

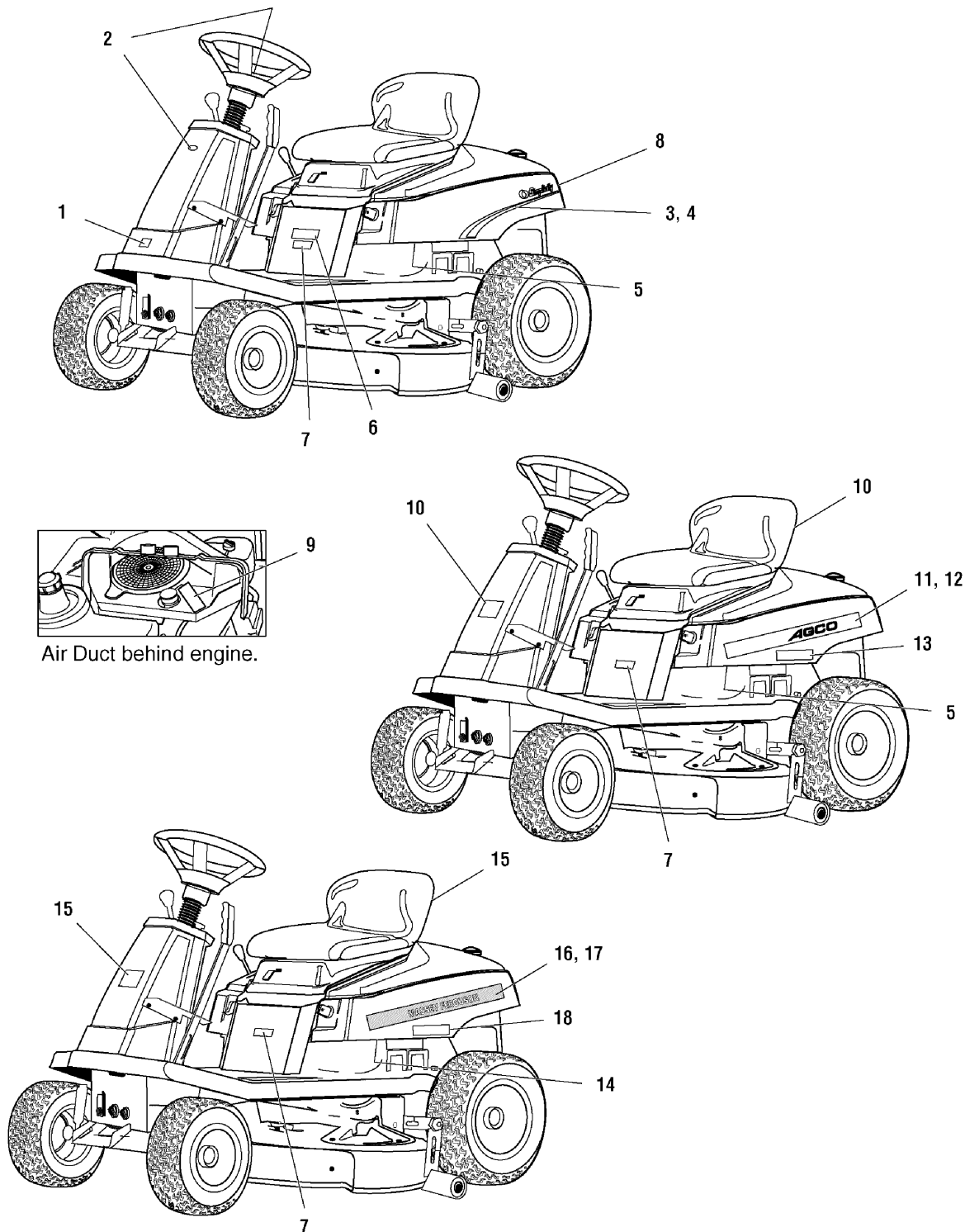

Air Duct behind engine.

### The above parts group applies to the following Mfg. Nos.:

- 1694462 - Coronet      2690802 - Coronet
- 1694463 - Coronet
- 1694464 - 2413H
- 1694510 - Coronet
- 1694536 - 2413
- 2690800 - Coronet

## Decals Group - Brand & Model

REF NO	PART NO.	QTY.	DESCRIPTION
1	*	1	DECAL, CE, (Export Only)
2	1731418SM	2	DECAL, Icon, Simplicity
3	1722768SM	1	DECAL, Seat Deck, LH
4	1722767SM	1	DECAL, Seat Deck, RH
5	1720454SM	1	DECAL, Touch-up Paint, Deep Orange & Charcoal Gray
6	1722769SM	1	DECAL, "CORONET"
7	1722778SM	1	DECAL, 13 HP
7	1736253SM	1	DECAL, 13.5 HP
7	1722549SM	1	DECAL, 16 HP
8	1722551SM	2	DECAL, Simplicity
9	1724468SM	1	DECAL, Briggs & Stratton, 13 HP, INTEK
10	1708926SM	2	DECAL, Logo, AGCO
11	1722853SM	1	DECAL, Seat Deck AGCO, LH
12	1722854SM	1	DECAL, Seat Deck AGCO, RH
13	1722856SM	2	DECAL, Model, 413H
14	1725072SM	1	DECAL, Touch-up Pain, Red & Gray
15	1714363SM	2	DECAL, Logo, Massey Ferguson
16	1722851SM	1	DECAL, Seat Deck, LH
17	1722852SM	1	DECAL, Seat Deck, RH
18	1722859SM	2	DECAL, Model, 2413

### Footnotes

Note\* Not a servicable part.

---

### The above parts group applies to the following Mfg. Nos.:

1694462 - Coronet      2690802 - Coronet  
1694463 - Coronet  
1694464 - 2413H  
1694510 - Coronet  
1694536 - 2413  
2690800 - Coronet

**Decals Group - Common & Safety**

**NOTE: Unless noted otherwise,  
use the standard hardware torque  
specification chart.**

C986490

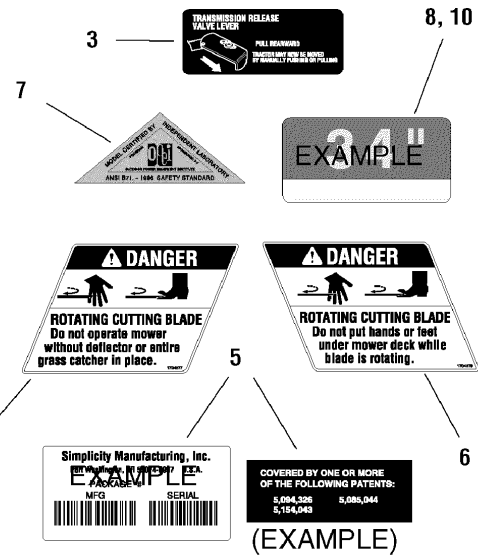
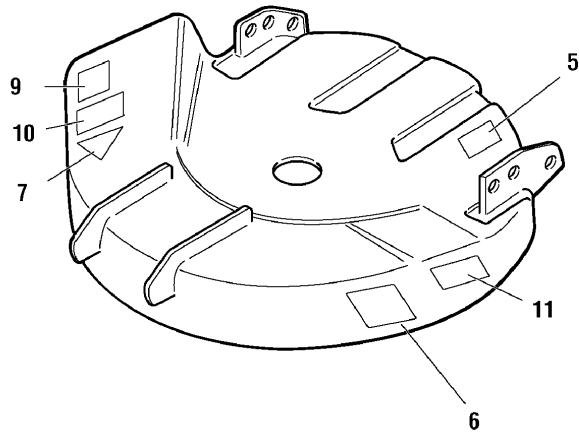
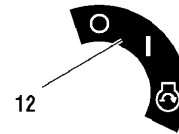
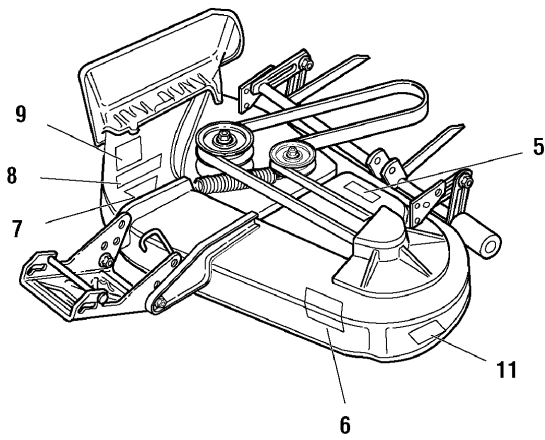
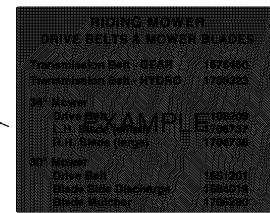
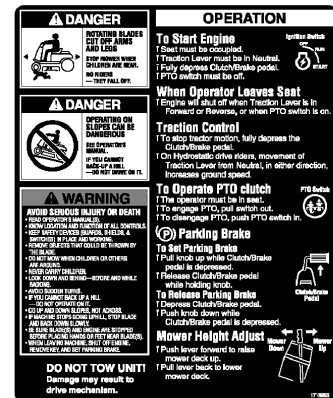
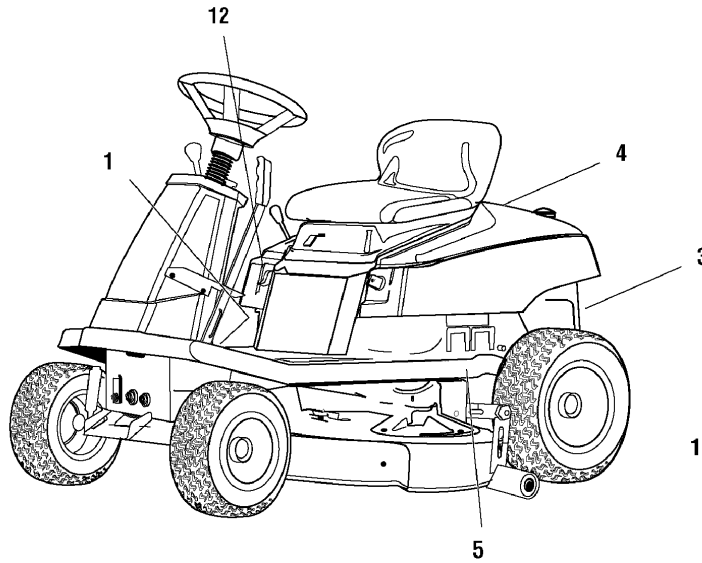

**The above parts group applies to the following Mfg. Nos.:**

- 1694462 - Coronet          2690802 - Coronet
- 1694463 - Coronet
- 1694464 - 2413H
- 1694510 - Coronet
- 1694536 - 2413
- 2690800 - Coronet



## ***Decals Group - Common & Safety***

---

<b>REF NO</b>	<b>PART NO.</b>	<b>QTY.</b>	<b>DESCRIPTION</b>
1	1726347SM	1	DECAL, Operating Instructions, English
1	1726336SM	1	DECAL, Operating Instructions, Export
3	1726341SM	1	DECAL, Transmission Release (Hydro models only)
4	1726335SM	1	DECAL, Belt & Blade Replacement
5	*	1	I.D. PLATE (Not Serviced)
6	1704276SM	1	DECAL, Danger, Rotating Cutting Blade
7	*	1	DECAL, OPEI, (Not Serviced)
8	1722786SM	1	DECAL, Cutting Width - 34", Silver on Black
9	1704277SM	1	DECAL, Danger, Chute In Place
10	1722785SM	1	DECAL, Cutting Width - 30", Silver on Black
11	1722771SM	1	DECAL, Free Floating Mower
12	1722806SM	1	DECAL, Ignition Switch Symbols, White on Black

### **Footnotes**

Note\* Not a servicable part.

---

### **The above parts group applies to the following Mfg. Nos.:**

1694462 - Coronet      2690802 - Coronet  
1694463 - Coronet  
1694464 - 2413H  
1694510 - Coronet  
1694536 - 2413  
2690800 - Coronet

## 30" Mower Deck - Drive & Arbor

984825

**NOTE:** Unless noted otherwise,  
use the standard hardware torque  
specification chart.

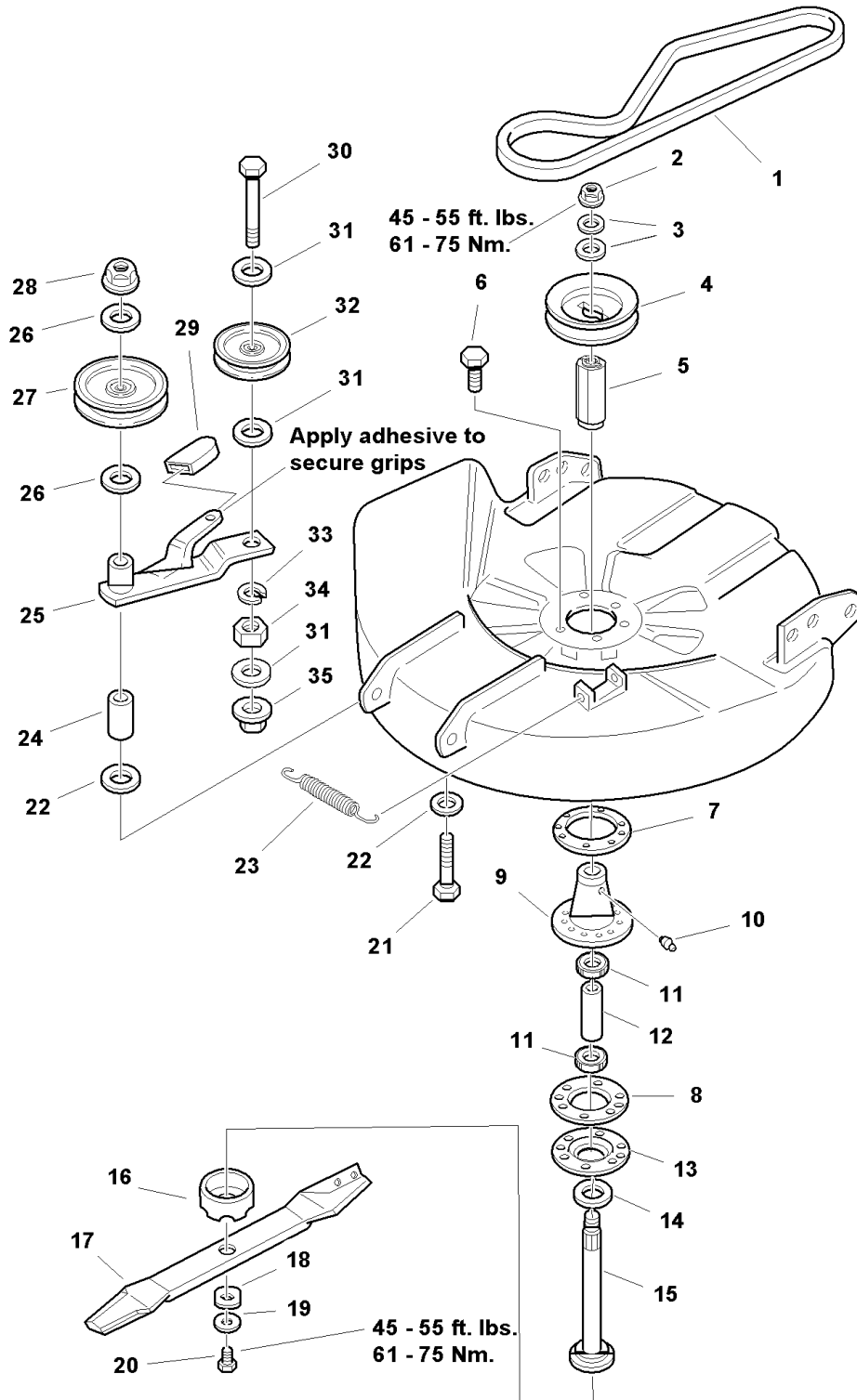

**The above parts group applies to the following Mfg. Nos.:**

1692543 - 30" Mower  
1694053 - 30" Mower  
1694511 - 30" Mower  
1694537 - 30" Mower  
2690800 - Coronet

### 30" Mower Deck - Drive & Arbor

REF NO	PART NO.	QTY.	DESCRIPTION
1	1719746SM	1	V-BELT
2	1714419SM	1	NUT, Hex Flange, 9/16-18
3	1713675SM	2	WASHER, Belleville
4	1713092SM	1	PULLEY
5	1713613SM	1	HUB, Pulley, 1-3/16
6	1960373SM	6	CAPSCREW, Hex Head, Taptite, 5/16-18 x 1
7	1677274ASM	1	ADAPTER, Arbor
8	1707335SM	1	GASKET, Foam
9	1713338ASM	1	HOUSING ASSEMBLY, Arbor Bottom, w/Lube Fitting (Includes Ref. No. 10)
10	1704314SM	1	FITTING, Grease
11	1705897SM	2	BEARING
12	1732543SM	1	SPACER
13	1713199ASM	1	COVER, Arbor Housing
14	1713619SM	1	WASHER, Cupped
15	1713609SM	1	SHAFT, Arbor, 5-53/64"
16	1713196SM	1	SHIELD, Grass, Lower
17	1664019ASM	1	BLADE, Mower, 30"
18	1713089SM	1	WASHER, Hex
19	1656916SM	1	WASHER, Spring
20	2823471SM	1	CAPSCREW, Hex Head, 7/16-14 x 1, GR 8
21	1923903SM	1	CAPSCREW, Hex Head, 3/8-16 x 3
22	1924356SM	2	WASHER, Flat, 3/8 x 1-1/2 x 1/8
23	1715435SM	1	SPRING
24	1669105SM	1	SPACER
25	1708562SM	1	LEVER ASSEMBLY
26	1924940SM	2	WASHER, Plain, 3/8
27	1707435SM	1	PULLEY ASSEMBLY Idler, Fixed, 6" Dia.
28	1928352SM	1	NUT, Hex, Whizlock, 3/8-16
29	1708966SM	1	GRIP, Lever
30	1923701SM	1	CAPSCREW, Hex Head, 3/8-16 x 2
31	1922755SM	3	WASHER, 13/32 x 1 x 1/8
32	1704926SM	1	IDLER PULLEY, Backside
33	1916965SM	1	LOCKWASHER, 3/8
34	1916950SM	1	NUT, Hex, 3/8
35	1928731SM	1	NUT, Hex, Lock, 3/8-16

#### Footnotes

---

**The above parts group applies to the following Mfg. Nos.:**

1692543 - 30" Mower  
1694053 - 30" Mower  
1694511 - 30" Mower  
1694537 - 30" Mower  
2690800 - Coronet

## 30" Mower Deck - Housing & Height Adjustment (CE/Export)

986458

NOTE: Unless noted otherwise,  
use the standard hardware torque  
specification chart.

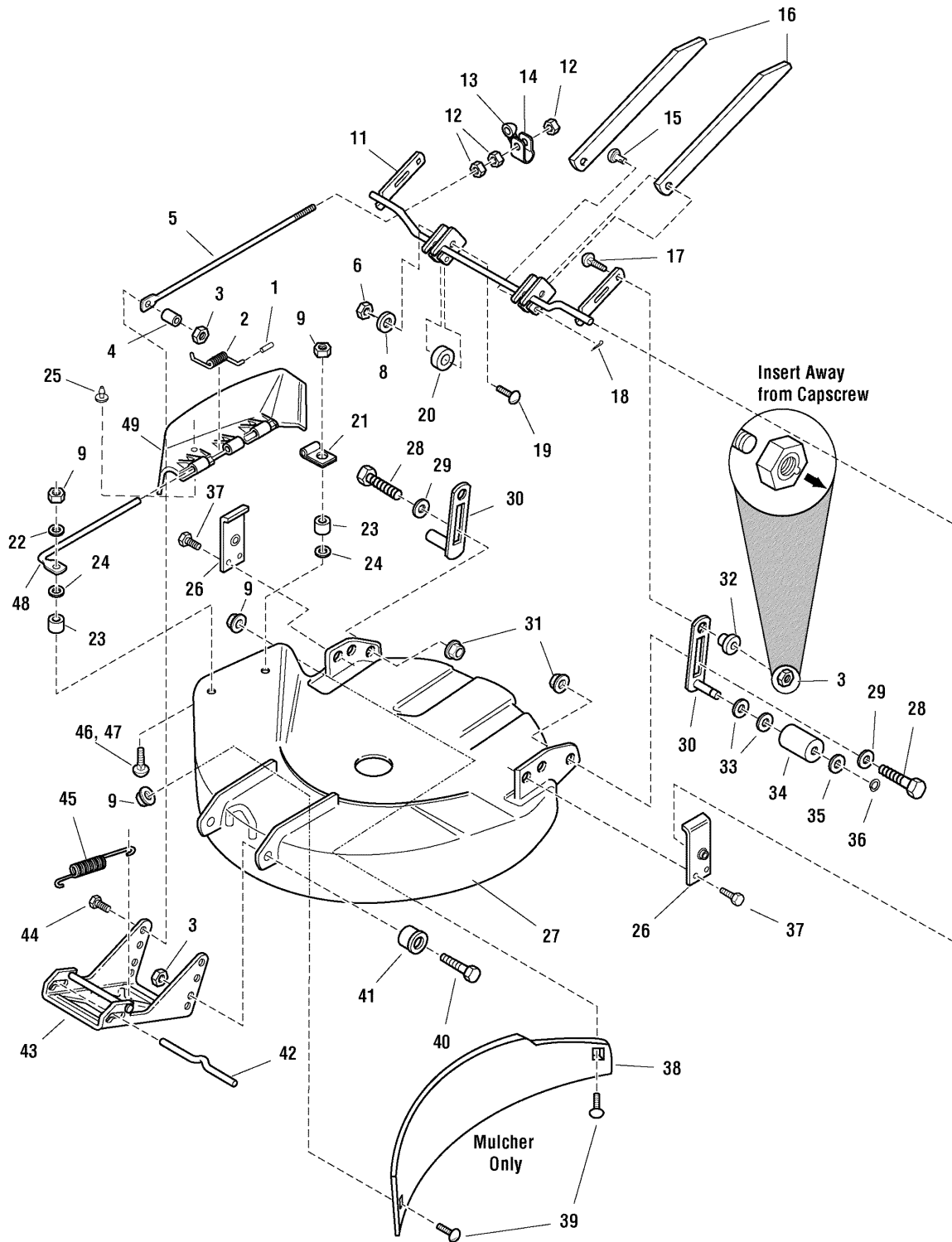

The above parts group applies to the following Mfg. Nos.:

1694511 - 30" Mower

1694537 - 30" Mower

### 30" Mower Deck - Housing & Height Adjustment (CE/Export)

REF NO	PART NO.	QTY.	DESCRIPTION
1	1723323SM	1	CAP, Spring End
2	7101082SM	1	SPRING, Torsion
3	2860681SM	5	NUT, Hex, ALUM Lock, 3/8
4	1611705SM	1	SPACER
5	1707300SM	1	ROD, Adjustment
6	1927557SM	2	NUT, Hex Flange Whiz Lock, 5/16-18
8	1919326SM	2	WASHER
9	1920397SM	4	NUT, Hex ESNA, 1/4-20
11	1707540ASM	1	ARM ASSEMBLY, Mower
12	1913744SM	3	JAMNUT, Hex, 3/8-16
13	1671260SM	1	SPACER
14	1707280ASM	1	TRUNNION
15	1655651SM	2	PIN, Locking
16	1709209ASM	2	BAR, Mower Transport
17	1931352SM	2	CARRIAGE BOLT, 3/8-16 x 1-1/2
18	1960074SM	2	PIN, Retaining
19	1960223SM	2	CARRIAGE BOLT, 5/15-18 x 1-1/4
20	1704716SM	2	SPACER
21	1704873SM	1	CLAMP
22	1921319SM	3	WASHER, Plain (1 Required for Export)
23	1700692SM	2	SPACER (Export)
24	1960518SM	2	PUSHNUT, 1/4
25	1718611SM	1	PLUG, Hole
26	1708250ASM	2	PLATE, Pivot Support
27	1685670SM	1	HOUSING ASSEMBLY, 30" (Orange)
27	1687157SM	1	HOUSING ASSEMBLY, 30" (Red)
27	1687135SM	1	HOUSING ASSEMBLY, 30" (Black)
28	2172622SM	2	BOLT, Shoulder
29	1924361SM	2	WASHER, Flat
30	1708519ASM	2	SUPPORT ASSEMBLY, Roller
31	1928352SM	2	NUT, Hex, Flange, Whizlock, 3/8-16
32	1704082SM	2	NUT, Adjustment
33	1924366SM	4	WASHER, Plain, 21/32 x 1-1/8 x 7/64
34	1668487SM	2	ROLLER
35	1960020SM	2	WASHER, 21/32 x 1-1/8 x 1/16
36	2153124SM	2	RING, Retaining
37	1664847SM	4	CAPSCREW, Taptite, 5/16-18 x 3/4
39	1931333SM	2	CARRIAGE BOLT, 5/16-18 x 3/4, G5
38	1709282ASM	1	PLATE, Discharge (30" Mulcher)
40	1921968SM	2	CAPSCREW, Hex, 3/8-16 x 1 3/8
41	1732443SM	1	SPACER
42	1715759SM	1	ROD, Latch, Hitch

#### Footnotes

The above parts group applies to the following Mfg. Nos.:

1694511 - 30" Mower

1694537 - 30" Mower

# 30" Mower Deck - Housing & Height Adjustment (CE/Export)

986458

NOTE: Unless noted otherwise,  
use the standard hardware torque  
specification chart.

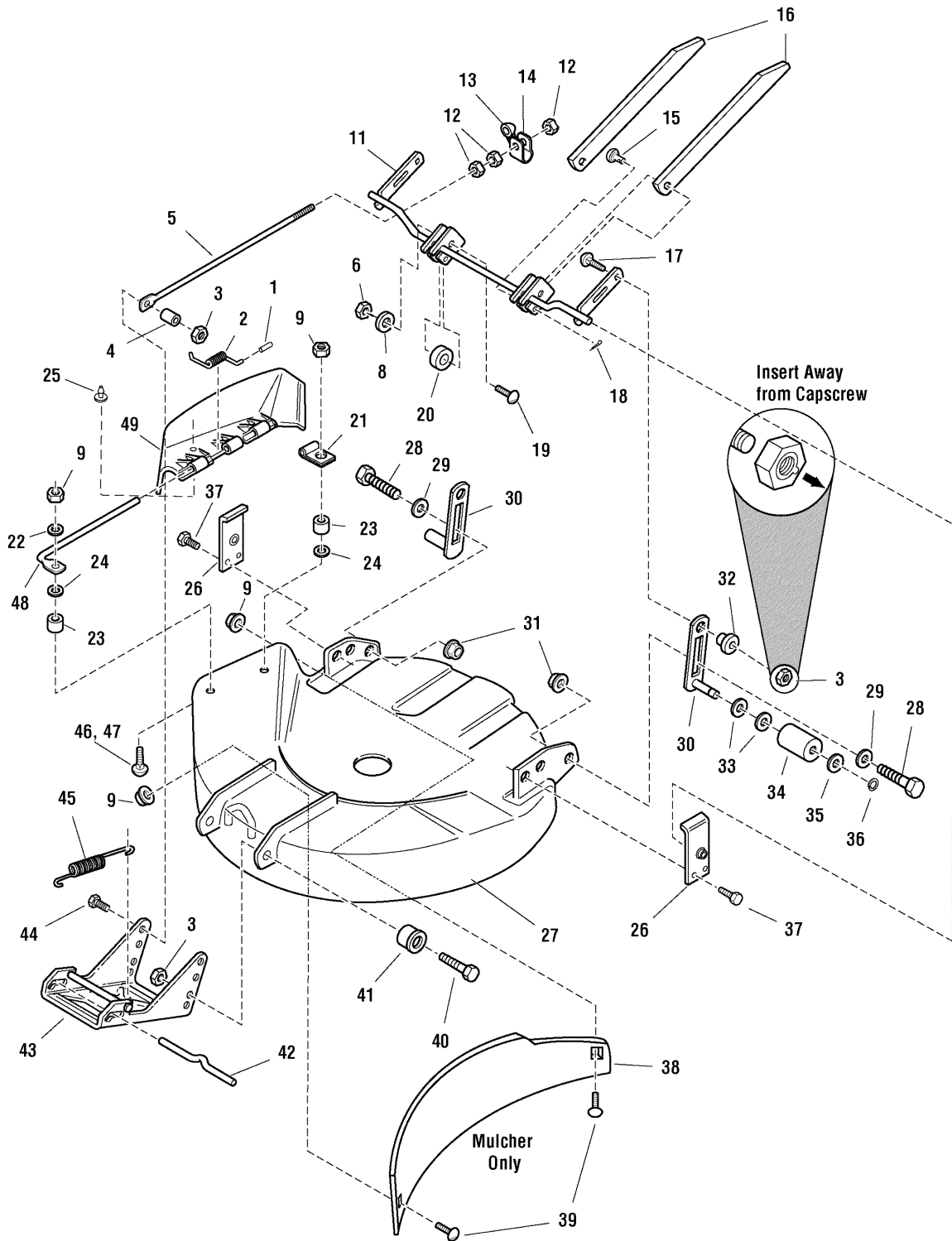

The above parts group applies to the following Mfg. Nos.:

1694511 - 30" Mower

1694537 - 30" Mower

### **30" Mower Deck - Housing & Height Adjustment (CE/Export)**

---

<b>REF NO</b>	<b>PART NO.</b>	<b>QTY.</b>	<b>DESCRIPTION</b>
43	1707432ASM	1	HITCH ASSEMBLY
44	1921210SM	1	CAPSCREW, Hex Head, 3/8-16 x 1
45	2156302SM	1	SPRING
46	1931317SM	2	CARRIAGE BOLT, 1/4-20 x 3/4
47	1931320SM	2	CARRIAGE BOLT, 1/4-20 x 1-1/4 (Export)
48	1664947SM	1	ROD, Deflector
49	1705449SM	1	DEFLECTOR, Plastic

#### **Footnotes**

---

**The above parts group applies to the following Mfg. Nos.:**

1694511 - 30" Mower

1694537 - 30" Mower

# 30" Mower Deck - Housing, Hitch & Height Adjustment

984421

NOTE: Unless noted otherwise,  
use the standard hardware torque  
specification chart.

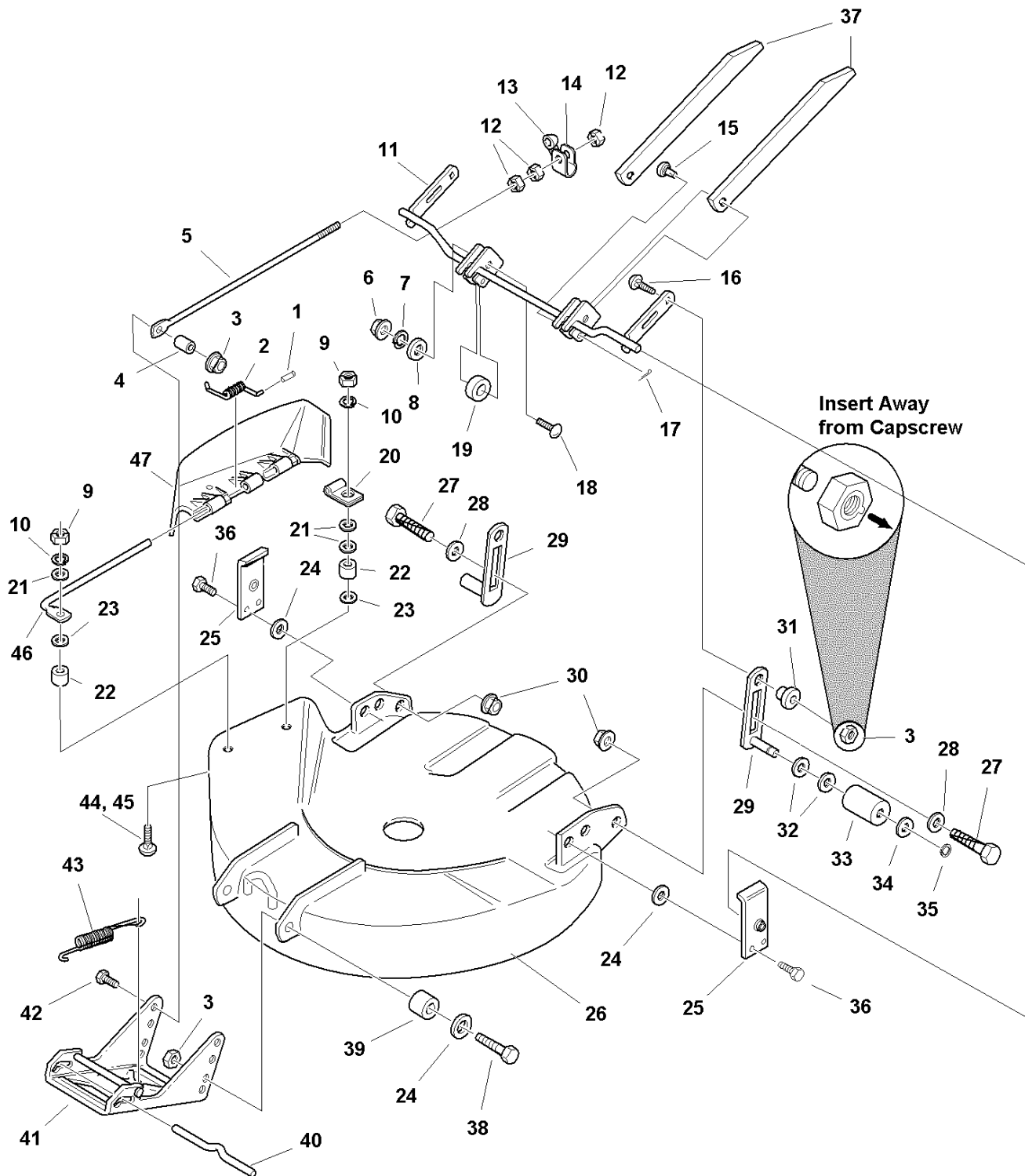

The above parts group applies to the following Mfg. Nos.:

- 1692543 - 30" Mower
- 1694053 - 30" Mower
- 2690800 - Coronet



### 30" Mower Deck - Housing, Hitch & Height Adjustment

REF NO	PART NO.	QTY.	DESCRIPTION
1	1723323SM	1	CAP, Spring End
2	7101082SM	1	SPRING, Torsion
3	2860681SM	5	NUT, Hex, ALUM Lock, 3/8
4	1611705SM	1	SPACER
5	1707300SM	1	ROD, Adjustment
6	1917372SM	2	NUT, Hex, 5/16-18
7	1917356SM	2	LOCKWASHER, 5/16
8	1919326SM	2	WASHER
9	1920397SM	2	NUT, Hex, 1/4-20 ESNA
11	1707540ASM	1	ARM ASSEMBLY, Mower
12	1913744SM	3	JAMNUT, Hex, 3/8-16
13	1671260SM	1	SPACER
14	1707280ASM	1	TRUNNION
15	1733568SM	2	PIN, Locking
16	1931352SM	2	CARRIAGE BOLT, 3/8-16 x 1-1/2
17	1960074SM	2	PIN, Retaining
18	1960223SM	2	CARRIAGE BOLT, 5/15-18 x 1-1/4
19	1704716SM	2	SPACER
20	1704873SM	1	CLAMP
21	1921319SM	3	WASHER, Plain (1 Required for Export)
22	1700692SM	2	SPACER (Export)
23	1960518SM	2	PUSHNUT, 1/4
24	1924940SM	6	WASHER, Flat, 3/8
25	1708250ASM	2	PLATE, Pivot Support
26	1685670SM	1	HOUSING ASSEMBLY, 30" (Orange)
26	1687157SM	1	HOUSING ASSEMBLY, 30" (Red)
26	1687135SM	1	HOUSING ASSEMBLY, 30" (Black)
27	2172622SM	2	BOLT, Shoulder
28	1924361SM	2	WASHER, Flat
29	1708519ASM	2	SUPPORT ASSEMBLY, Roller
30	1928352SM	2	NUT, Hex, Flange, Whizlock, 3/8-16
31	1704082SM	2	NUT, Adjustment
32	1924366SM	4	WASHER, Plain, 21/32 x 1-1/8 x 7/64
33	1668487SM	2	ROLLER
34	1960020SM	2	WASHER, 21/32 x 1-1/8 x 1/16
35	2153124SM	2	RING, Retaining
36	1664847SM	4	CAPSCREW, Taptite, 5/16-18 x 3/4
37	1709209ASM	2	BAR, Mower Transport
38	1921968SM	2	CAPSCREW, Hex, 3/8-16 x 1-3/8
39	2157081SM	2	SPACER
40	1715759SM	1	ROD, Latch, Hitch
41	1707432ASM	1	HITCH ASSEMBLY
42	1921210SM	1	CAPSCREW, Hex Head, 3/8-16 x 1

#### Footnotes

The above parts group applies to the following Mfg. Nos.:

1692543 - 30" Mower  
 1694053 - 30" Mower  
 2690800 - Coronet

## 30" Mower Deck - Housing, Hitch & Height Adjustment

984421

NOTE: Unless noted otherwise,  
use the standard hardware torque  
specification chart.

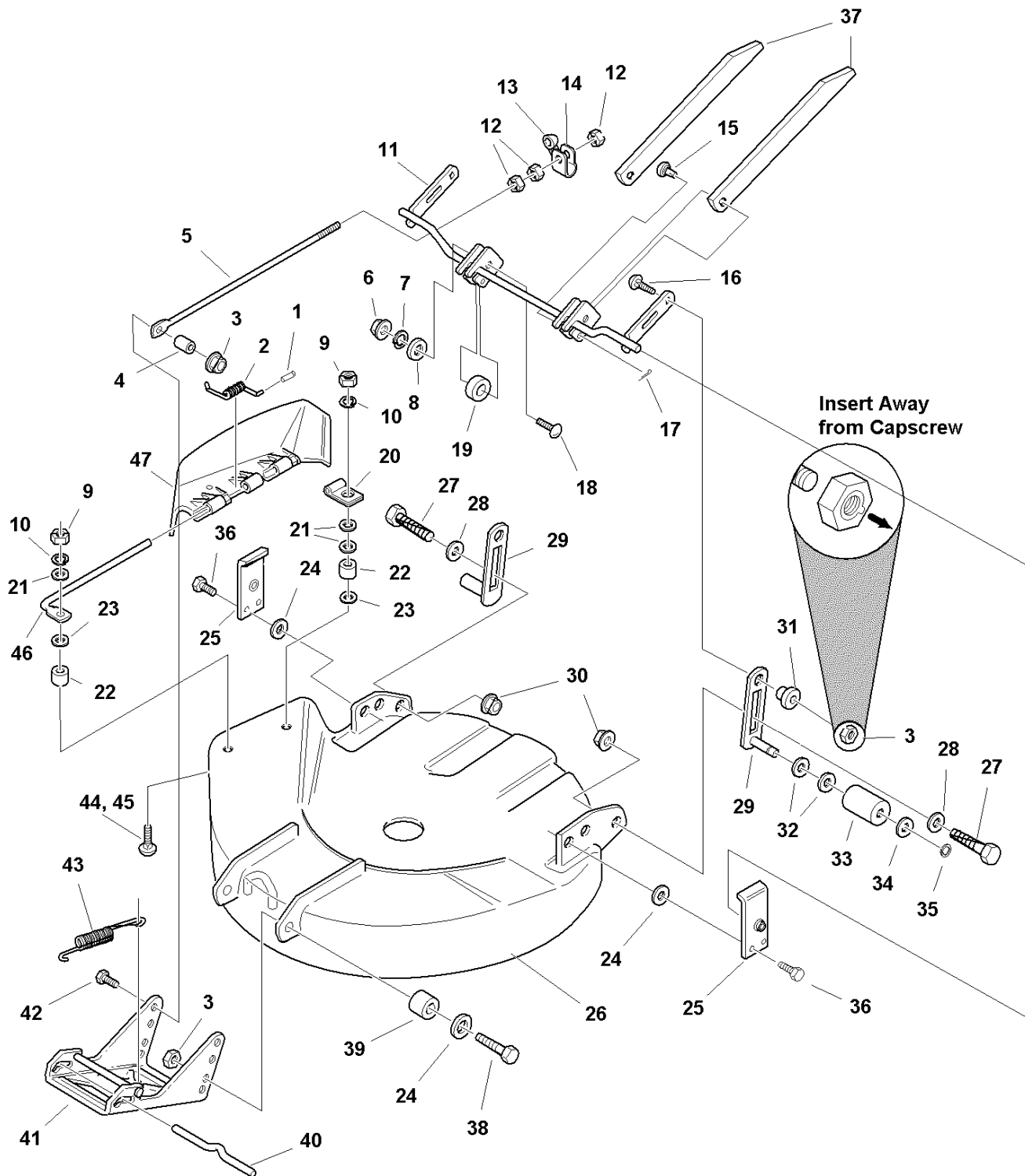

The above parts group applies to the following Mfg. Nos.:

- 1692543 - 30" Mower
- 1694053 - 30" Mower
- 2690800 - Coronet

### **30" Mower Deck - Housing, Hitch & Height Adjustment**

---

<b>REF NO</b>	<b>PART NO.</b>	<b>QTY.</b>	<b>DESCRIPTION</b>
43	2156302SM	1	SPRING, Extension
44	1931317SM	2	CARRIAGE BOLT, 1/4-20 x 3/4
45	1931320SM	2	CARRIAGE BOLT, 1/4-20 x 1-1/4 (Export)
46	1664947SM	1	ROD, Deflector
47	1705449SM	1	DEFLECTOR, Plastic

---

#### **Footnotes**

---

**The above parts group applies to the following Mfg. Nos.:**

1692543 - 30" Mower

1694053 - 30" Mower

2690800 - Coronet

# 34" Mower Deck - Drive & Arbor

984826

**NOTE:** Unless noted otherwise, use the standard hardware torque specification chart.

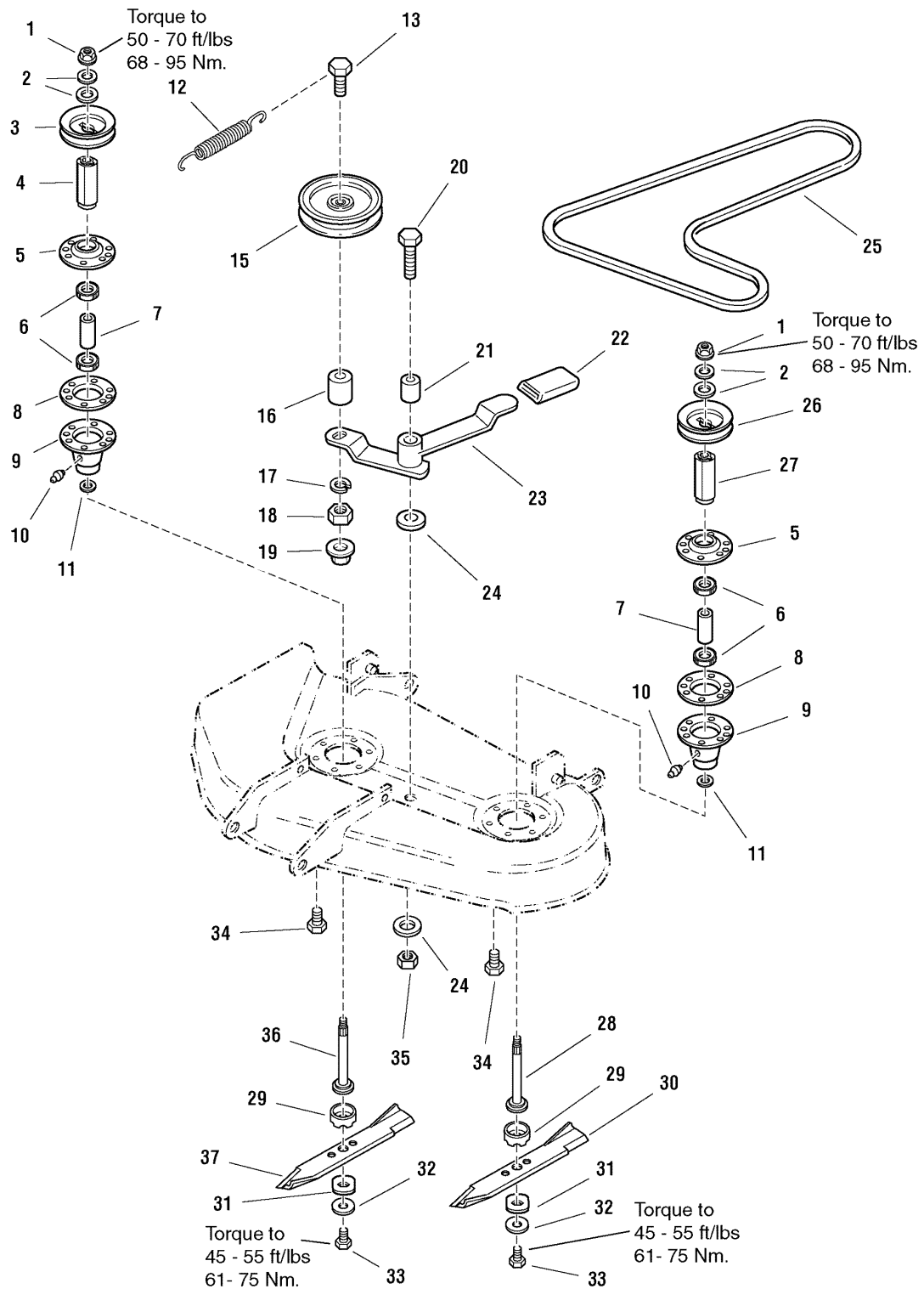

**The above parts group applies to the following Mfg. Nos.:**

- 1692545 - 34" Mower
- 2690802 - Coronet

### 34" Mower Deck - Drive & Arbor

REF NO	PART NO.	QTY.	DESCRIPTION
1	1714419SM	2	NUT, Hex, Flange, 9/16-18
2	1713675SM	4	WASHER, Belleville
3	1713091SM	1	PULLEY, 5"
4	1713614SM	1	HUB, Pulley, 1-35/64"
5	1713199ASM	2	COVER, Arbor Housing ASSEMBLY
6	1705897SM	4	BEARING
7	1732543SM	2	SPACER
8	1707335SM	2	GASKET, Foam
9	1713338ASM	2	HOUSING ASSEMBLY, Arbor Bottom, w/Lube Fitting (Includes Ref. No. 10)
10	1704314SM	2	FITTING, Grease
11	1713619SM	2	WASHER
12	2164213SM	1	SPRING
13	1921972SM	1	CAPSCREW, 3/8-16 x 2-1/2
15	1704926SM	1	PULLEY, Idler, Backside
16	1667812SM	1	SPACER
17	1916965SM	1	LOCKWASHER, 3/8
18	1916950SM	1	NUT, Hex, 3/8-16
19	1930645SM	1	NUT, Hex, Flange, Lock, 3/8-16
20	1928957SM	1	CAPSCREW, Hex Head, 3/8-16 x 2-3/4
21	1657242SM	1	SPACER
22	1708966SM	1	GRIP, Lever
23	1708561SM	1	LEVER ASSEMBLY
24	1924356SM	2	WASHER, Flat, 3/8
25	1723391SM	1	V-BELT
26	1713090SM	1	PULLEY, 3-3/4"
27	1713613SM	1	HUB, Pulley, 1-3/16"
28	1713609SM	1	SHAFT, Arbor, 5-53/64"
29	1713196SM	2	SHIELD, Grass, Lower
30	1706737ASM	1	BLADE, 14-27/64"
31	1713089SM	2	WASHER, Hex
32	1656916SM	2	WASHER, Spring
33	2823471SM	2	CAPSCREW, Hex Head, 7/16-14 x 1-1/4, GR 8
34	1664847SM	12	CAPSCREW Taptite, 5/16-18 x 3/4
35	1928352SM	1	NUT, Hex, 3/8-16
36	1713610SM	1	SHAFT, Arbor, 6-33/64"
37	1706738ASM	1	BLADE, 19-29/32"

#### Footnotes

The above parts group applies to the following Mfg. Nos.:

1692545 - 34" Mower  
2690802 - Coronet

## 34" Mower Deck - Height Adjustment

J984418

NOTE: Unless noted otherwise,  
use the standard hardware torque  
specification chart.

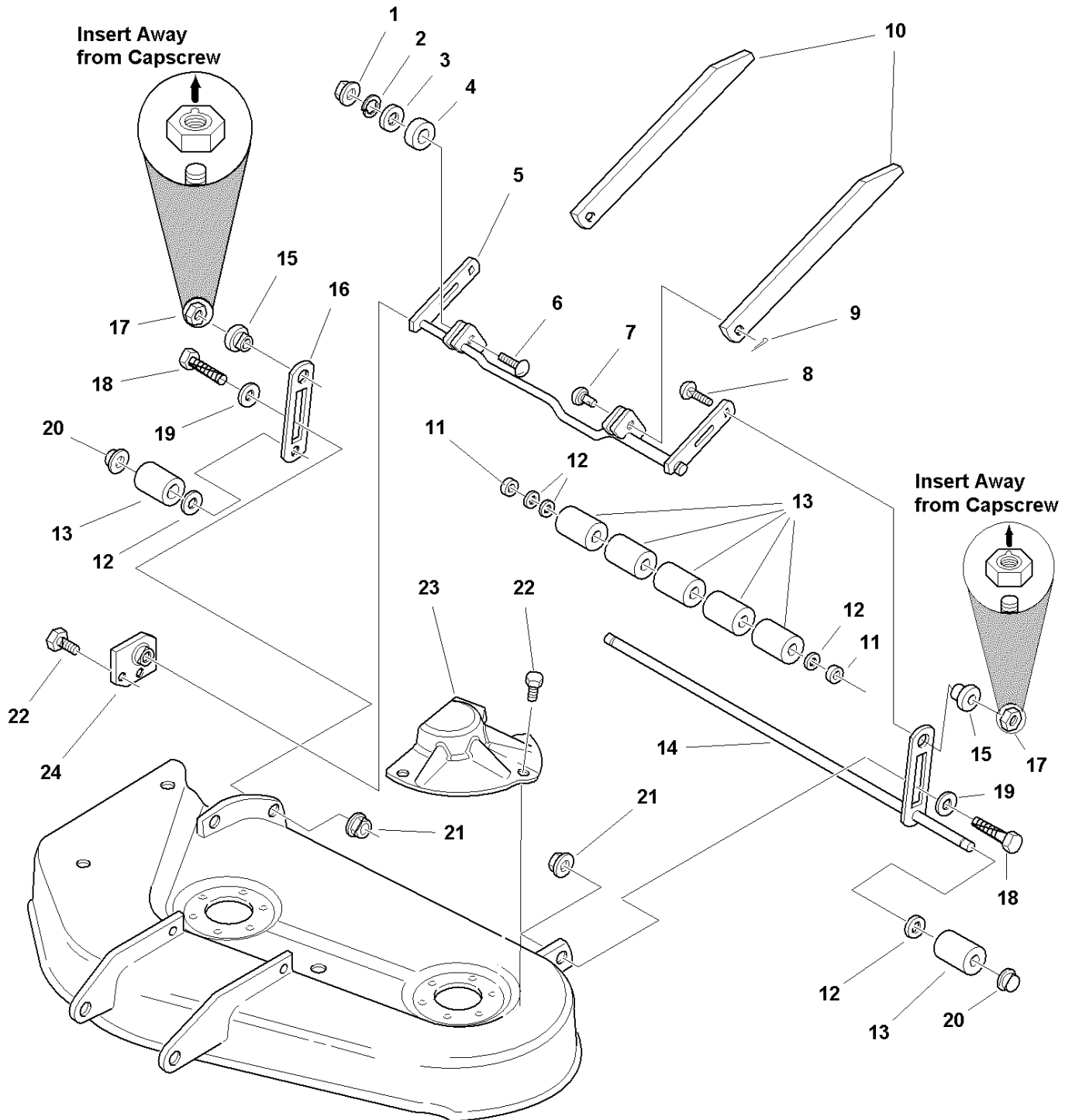

The above parts group applies to the following Mfg. Nos.:

1692545 - 34" Mower

2690802 - Coronet

### 34" Mower Deck - Height Adjustment

REF NO	PART NO.	QTY.	DESCRIPTION
1	1917372SM	1	NUT, Hex, 5/16-18
2	1917356SM	2	LOCKWASHER, 5/16
3	1919326SM	2	WASHER
4	1704716SM	2	SPACER
5	1707286ASM	1	ARM ASSEMBLY
6	1960223SM	2	CARRIAGE BOLT, 5/16-18 x 1-1/4
7	1733568SM	2	PIN, Locking
8	1931352SM	2	CARRIAGE BOLT, 3/8-16 x 1-1/2
9	1960074SM	2	CLIP, Hair Pin
10	1709209ASM	2	BAR, Mower Transport
11	1602946SM	2	SPACER, Roller
12	1924366SM	5	WASHER, Flat, 5/8
13	1668513SM	7	ROLLER
14	1686682SM	1	SHAFT ASSEMBLY, Roller (Includes Ref. 20)
15	1704082SM	2	NUT, Adjustment
16	1708520ASM	1	PLATE, Support, RH
17	2860681SM	2	NUT, Hex Alum Lock, 3/8
18	2172622SM	2	BOLT, Shoulder, 3/8-16
19	1924361SM	2	WASHER, Flat, 1/2
20	1960520SM	2	NUT, Push
21	1928352SM	2	NUT, Flange Lock, 3/8
22	1664847SM	5	CAPSCREW, Taptite, 5/16-18 x 5/8
23	1707567SM	1	COVER, Arbor
24	1708564ASM	1	PLATE, Support

### Footnotes

---

**The above parts group applies to the following Mfg. Nos.:**

1692545 - 34" Mower  
2690802 - Coronet

## 34" Mower Deck - Housing, Hitch & Deflector

984418

NOTE: Unless noted otherwise,  
use the standard hardware torque  
specification chart.

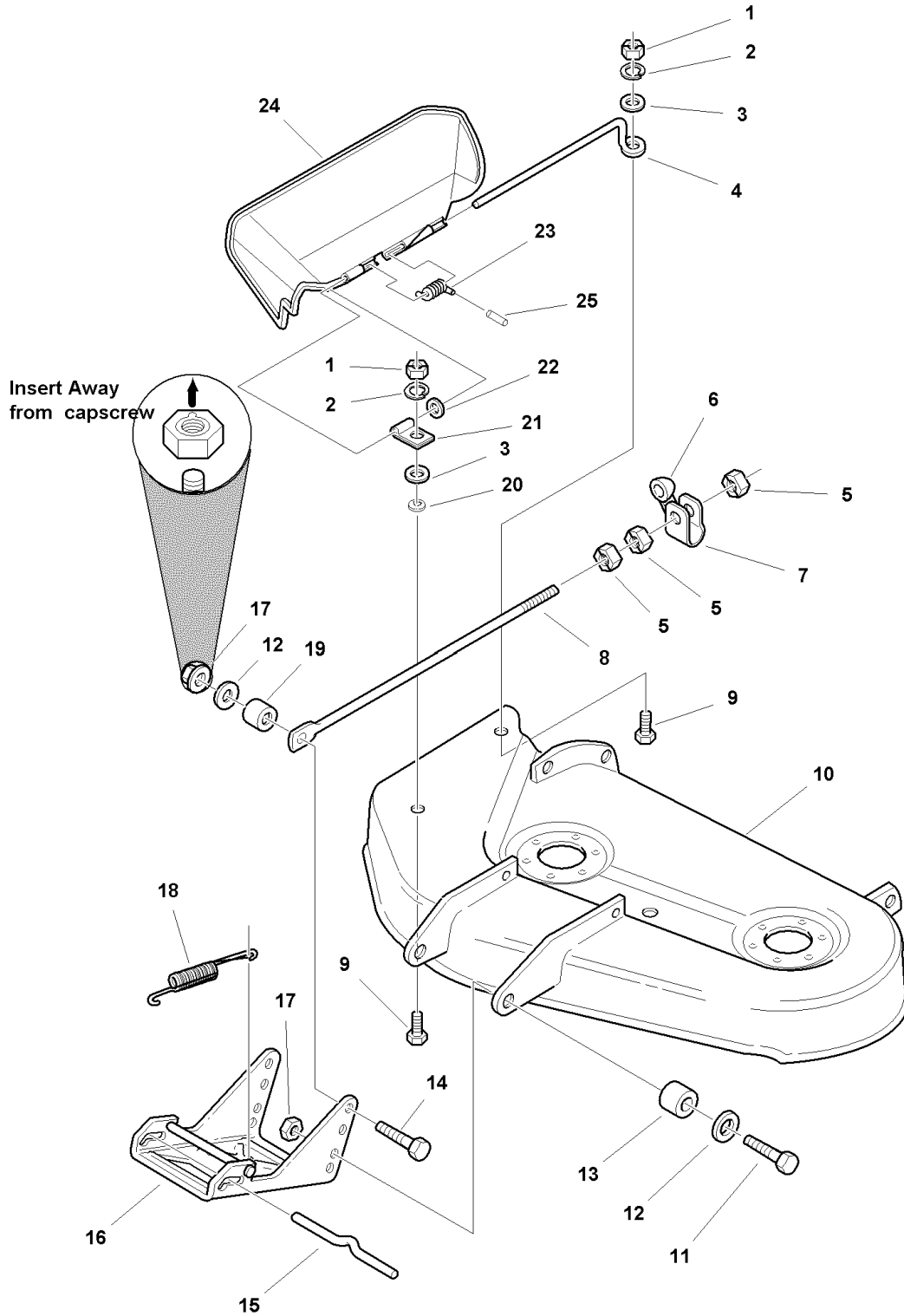

The above parts group applies to the following Mfg. Nos.:

1692545 - 34" Mower

2690802 - Coronet



### **34" Mower Deck - Housing, Hitch & Deflector**

<b>REF NO</b>	<b>PART NO.</b>	<b>QTY.</b>	<b>DESCRIPTION</b>
1	1916622SM	2	NUT, Hex, 1/4-20
3	1960353SM	2	WASHER, Flat, 17/64 x 27/32 x 1/8
4	1706709SM	1	ROD, Deflector, Front
5	1913744SM	3	JAMNUT, Hex, 1/2-13
6	1671260SM	1	SPACER
7	1707280ASM	1	TRUNNION
8	1707300SM	1	ROD, Adustment
9	1931318SM	2	CARRIAGE BOLT, 1/4-20 X 7/8
10	1685672SM	1	HOUSING ASSEMBLY, 34" (Orange)
10	1687137SM	1	HOUSING ASSEMBLY, 34" (Black)
11	1921968SM	2	CAPSCREW, Hex Head, 3/8-16 x 1-3/8
12	1924940SM	3	WASHER, Flat, 3/8
13	2157081SM	2	SPACER
14	1921210SM	1	CAPSCREW, Hex Head, 3/8-16 x 1
15	1715759SM	1	ROD, Latch, Hitch
16	1707432ASM	1	HITCH ASSEMBLY
17	2860681SM	3	NUT, Hex Lock, Alm Insert, 3/8-16
18	2156302SM	1	SPRING
19	1611705SM	1	SPACER
20	1960518SM	1	PUSHNUT
21	1704873SM	1	CLAMP
22	1919326SM	1	WASHER
23	1723938SM	1	SPRING
24	1705449SM	1	DEFLECTOR, Plastic
25	1723323SM	1	CAP, Spring End

#### **Footnotes**

---

**The above parts group applies to the following Mfg. Nos.:**

1692545 - 34" Mower  
2690802 - Coronet

01	3/24/04	DWS
	NOTE *YELLOW* WAS PURPLE	
	REMOVED NEUTRAL SWITCH	
	REMOVED NOTE	
B	11/16/05	JRZ

THE FOLLOWING SAFETY STARTING & RUNNING CONDITIONS MUST BE MET FOR ALL ELECTRICAL WIRING, SWITCHES AND RELATED COMPONENTS.

- ALL UNITS MUST BE TESTED FOR CORRECT WIRING AND FUNCTION OF ALL CIRCUITS AND SWITCHES
- ENGINE OPERATION MUST STOP WHEN THE FOLLOWING CONDITIONS PREVAIL:
  - IGNITION SWITCH IS PLACED IN THE OFF POSITION
  - THE OPERATOR IS NOT SEATED WITH EITHER THE CLUTCH/BRAKE PEDAL RELEASED (UP) OR THE PTO IN THE ENGAGED POSITION.
  - TRANSMISSION IS PUT IN REVERSE WITHOUT OVERRIDE MODULE ENGORIZED.
- ENGINE MUST NOT START BY CONVENTIONAL MEANS UNLESS ALL OF THE FOLLOWING CONDITIONS ARE MET. EACH CONDITION MUST BE CHECKED THOUROUGHLY TO INSURE PROPER OPERATING SEQUENCE.
  - IGNITION SWITCH IS INTENTIONALLY PLACED IN THE START POSITION
  - SHIFT LEVER IS IN NEUTRAL
  - THE PTO SWITCH IS IN THE DISENGAGED POSITION
  - CLUTCH/BRAKE PEDAL IS FULLY DEPRESSED
- ENGINE MUST REMAIN RUNNING IF OPERATOR IS SEATED AND THE FOLLOWING CONDITIONS ARE MET
  - TRANSMISSION IS ENGAGED (CLUTCH/BRAKE PEDAL IS RELEASED (UP)
  - PTO IS ENGAGED AND OVERRIDE MODULE IS ENGORIZED
- IF OPERATOR IS NOT SEATED, THE ENGINE MUST CONTINUE TO RUN ONLY IF THE FOLLOWING CONDITIONS ARE MET.
  - PTO IS NOT ENGAGED
  - TRANSMISSION IS ENGAGED.
  - CLUTCH/BRAKE PEDAL MUST BE FULLY DEPRESSED
- FUNCTION OF SEAT SWITCH MUST BE TESTED WITH SWITCH MOUNTED IN PROPER POSITION IN SEAT

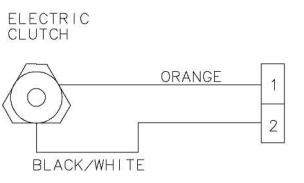
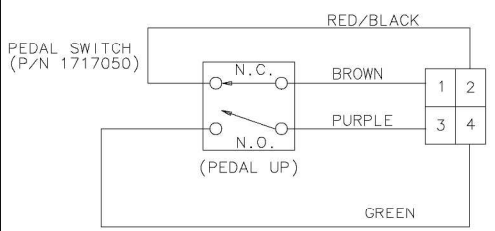
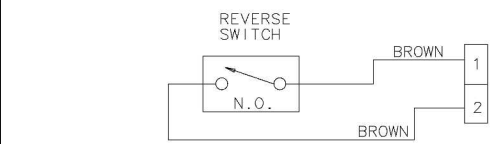

WIRING HARNESS 1726667

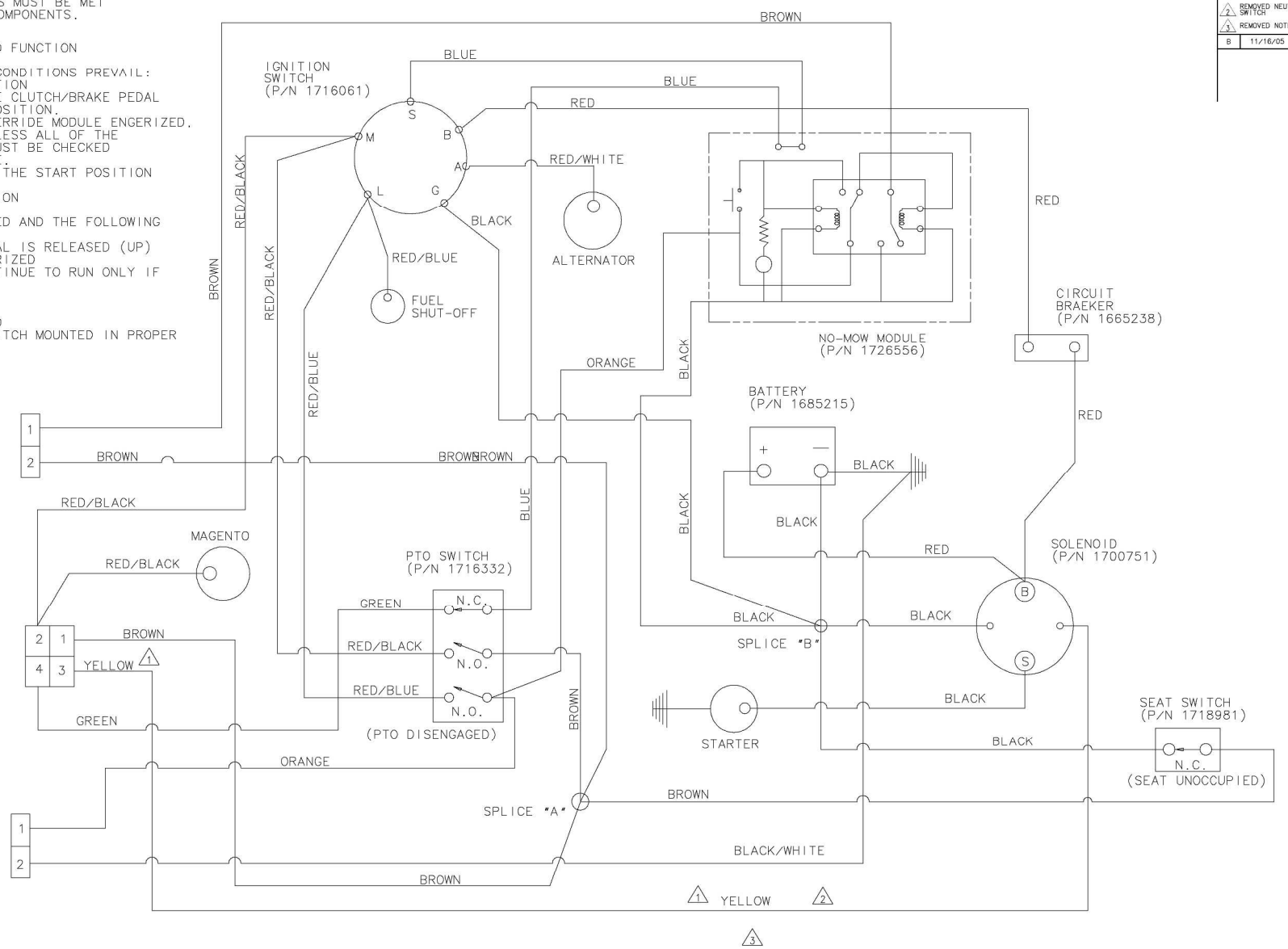

WIRING HARNESS 1726654

ITEM	PART NO.	QTY	DESCRIPTION
CONFIDENTIAL PROPERTY OF SIMPLICITY MFG., INC. PORT WASHINGTON, OHIO UNDER ENGINEERING PROTECTIO			NAME: WIRING SCHEMATIC CORONET
1-PLATE DIA 1/2" ±.01	ANGULAR	✓	MAT'L
2-PLATE DIA 1/2" ±.03			
3-PLATE DIA 1/2" ±.015	±1°	✓	MACHINED SURFACE TEXTURE
COMPUTER ENGINEERED			
DR DWS 1/21/04	SIMILAR TO 1719928	DWG SIZE D	LASER C/P
OR	SCALE	SHEET	PART NO.
AP	NTS	1 OF 1	1726655



# Hardware Identification & Torque Specifications

Torque Specification Chart								
FOR STANDARD METRIC MACHINE HARDWARE (Tolerance ± 20%)								
Property Class	5.6		8.8		10.9		12.9	
	Class 5.6		Class 8.8		Class 10.9		Class 12.9	
Size Of Hardware	in/lbs		in/lbs		in/lbs		in/lbs	
	ft/lbs	Nm.	ft/lbs	Nm.	ft/lbs	Nm.	ft/lbs	Nm.
M3	5.88	.56	13.44	1.28	19.2	1.80	22.92	2.15
M4	13.44	1.28	30.72	2.90	43.44	4.10	52.56	4.95
M5	26.4	2.50	60.96	5.75	5.97	8.10	7.15	9.7
M6	44.64	4.3	7.3	9.9	10.3	14	12.1	16.5
M7	5.2	7.1	12.1	16.5	16.9	23	19.9	27
M8	7.7	10.5	17.7	24	25	34	29	40
M10	15	21	35	48	50	67	59	81
M12	26	36	61	83	86.2	117	103	140
M14	42	58	101	132	136	185	162	220
M16	64	88	147	200	210	285	250	340
M18	89	121	202	275	287	390	346	470
M20	126	171	290	390	405	550	486	660
M22	169	230	390	530	559	745	656	890
M24	217	295	497	375	708	960	840	1140
M27	320	435	733	995	1032	1400	1239	1680
M30	435	590	995	1350	1401	1900	1681	2280
M33	590	800	1349	1830	1902	2580	2278	3090
M36	759	1030	1740	2360	2441	3310	2935	3980
M39	988	1340	2249	3050	3163	4290	3798	5150

The guides and ruler furnished below are designed to help you select the appropriate hardware.



**Nut, M8**

Thread Diameter (mm)  
Inside Diameter (in)  
Threads per inch

**Nut, 1/2-16**

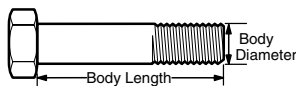

**Screw, M8- 1.25 x 25**

Thread Diameter (mm)  
Body Diameter  
Distance between threads (mm)  
Threads per inch  
Body Length (mm)  
Body Length (in)

**Screw, 1/2- 16 x 2**

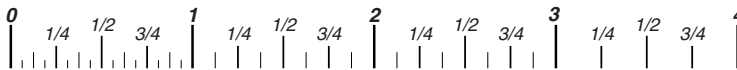

## Standard Hardware Sizing

When a washer or nut is identified as **1/2"** (M8), this is the *Nominal size*, meaning the *inside diameter* is 1/2 inch (8mm metric thread diameter); if a second number is present it represents the *threads per inch* (distance between threads).

When bolt or capscrew is identified as **1/2 - 16 x 2"** (M8 - 1.25 x 50 ), this means the *Nominal size*, or body diameter is 1/2 inch (8mm metric thread diameter), the second number, 16, represents the *threads per inch*, (*1.25 thread diameter*). The final number is the body length of the bolt or screw, 2 inches (50mm).

Torque Specification Chart						
FOR STANDARD MACHINE HARDWARE (Tolerance ± 20%)						
Hardware Grade	No Marks		No Marks		No Marks	
	SAE Grade 2		SAE Grade 5		SAE Grade 8	
Size Of Hardware	in/lbs		in/lbs		in/lbs	
	ft/lbs	Nm.	ft/lbs	Nm.	ft/lbs	Nm.
8-32	19	2.1	30	3.4	41	4.6
8-36	20	2.3	31	3.5	43	4.9
10-24	27	3.1	43	4.9	60	6.8
10-32	31	3.5	49	5.5	68	7.7
1/4-20	66	7.6	8	10.9	12	16.3
1/4-28	76	8.6	10	13.6	14	19.0
5/16-18	11	15.0	17	23.1	25	34.0
5/16-24	12	16.3	19	25.8	29	34.0
3/8-16	20	27.2	30	40.8	45	61.2
3/8-24	23	31.3	35	47.6	50	68.0
7/16-14	30	40.8	50	68.0	70	95.2
7/16-20	35	47.6	55	74.8	80	108.8
1/2-13	50	68.0	75	102.0	110	149.6
1/2-20	55	74.8	90	122.4	120	163.2
9/16-12	65	88.4	110	149.6	150	204.0
9/16-18	75	102.0	120	163.2	170	231.2
5/8-11	90	122.4	150	204.0	220	299.2
5/8-18	100	136	180	244.8	240	326.4
3/4-10	160	217.6	260	353.6	386	525.0
3/4-16	180	244.8	300	408.0	420	571.2
7/8-9	140	190.4	400	544.0	600	816.0
7/8-14	155	210.8	440	598.4	660	897.6
1-8	220	299.2	580	788.8	900	1,244.0
1-12	240	326.4	640	870.4	1,000	1,360.0

## NOTES

- These torque values are to be used for all hardware excluding: locknuts, self-tapping screws, thread forming screws, sheet metal screws and socket head setscrews.
- Recommended seating torque values for locknuts:
  - for prevailing torque locknuts - use 65% of grade 5 torques.
  - for flange whizlock nuts and screws - use 135% of grade 5 torques.
- Unless otherwise noted on assembly drawings, all torque values must meet this specification.

## Common Hardware Types

Hex Head Capscrew

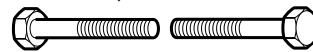

Washer



Lockwasher

Carriage Bolt



Hex Nut

## Wrench & Fastener Size Guide

1/4" Bolt or Nut Wrench—7/16"	5/16" Bolt or Nut Wrench—1/2"	3/8" Bolt or Nut Wrench—9/16"	7/16" Bolt or Nut Wrench (Bolt)—5/8" Wrench (Nut)—11/16"	1/2" Bolt or Nut Wrench—3/4"
M6 Bolt or Nut Wrench—10mm	M8 Bolt or Nut Wrench—13mm	M10 Bolt or Nut Wrench—17mm	M12 Bolt or Nut Wrench—19mm	M14 Bolt or Nut Wrench—22mm

**IT IS THE POLICY OF BRIGGS & STRATTON CORP. TO IMPROVE ITS PRODUCTS  
WHENEVER IT IS POSSIBLE AND PRACTICAL TO DO SO. WE RESERVE THE RIGHT TO  
MAKE CHANGES OR ADD IMPROVEMENTS AT ANY TIME WITHOUT INCURRING ANY  
OBLIGATION TO MAKE SUCH CHANGES ON PRODUCTS.**

**Briggs & Stratton Yard Power Products Group**

---

3515 N. 124 Street / PO Box 702  
Wauwatosa, WI 53222 USA

[www.simplicitymfg.com](http://www.simplicitymfg.com)

© Copyright 2010 by Briggs & Stratton Corporation  
Milwaukee, WI, USA. All rights reserved