



Parts Manual

Mfg. No: 1697293-00
1222EE SS NA 22" 11.5 Gross (2020),
Briggs

Model Components	Page
Auger Drive Group.....	4
Auger Group.....	6
Chute Group.....	8
Chute Rotation Group - Electric.....	10
Cover & Wheel Group.....	12
Engine Group.....	14
Handles & Controls Group.....	16
Light Panel Group.....	18
Torque Specification Chart.....	20

Not For
Reproduction

Auger Drive Group

Note: Unless noted otherwise, use the standard torque specifications

Mfg. No: 1697293-00

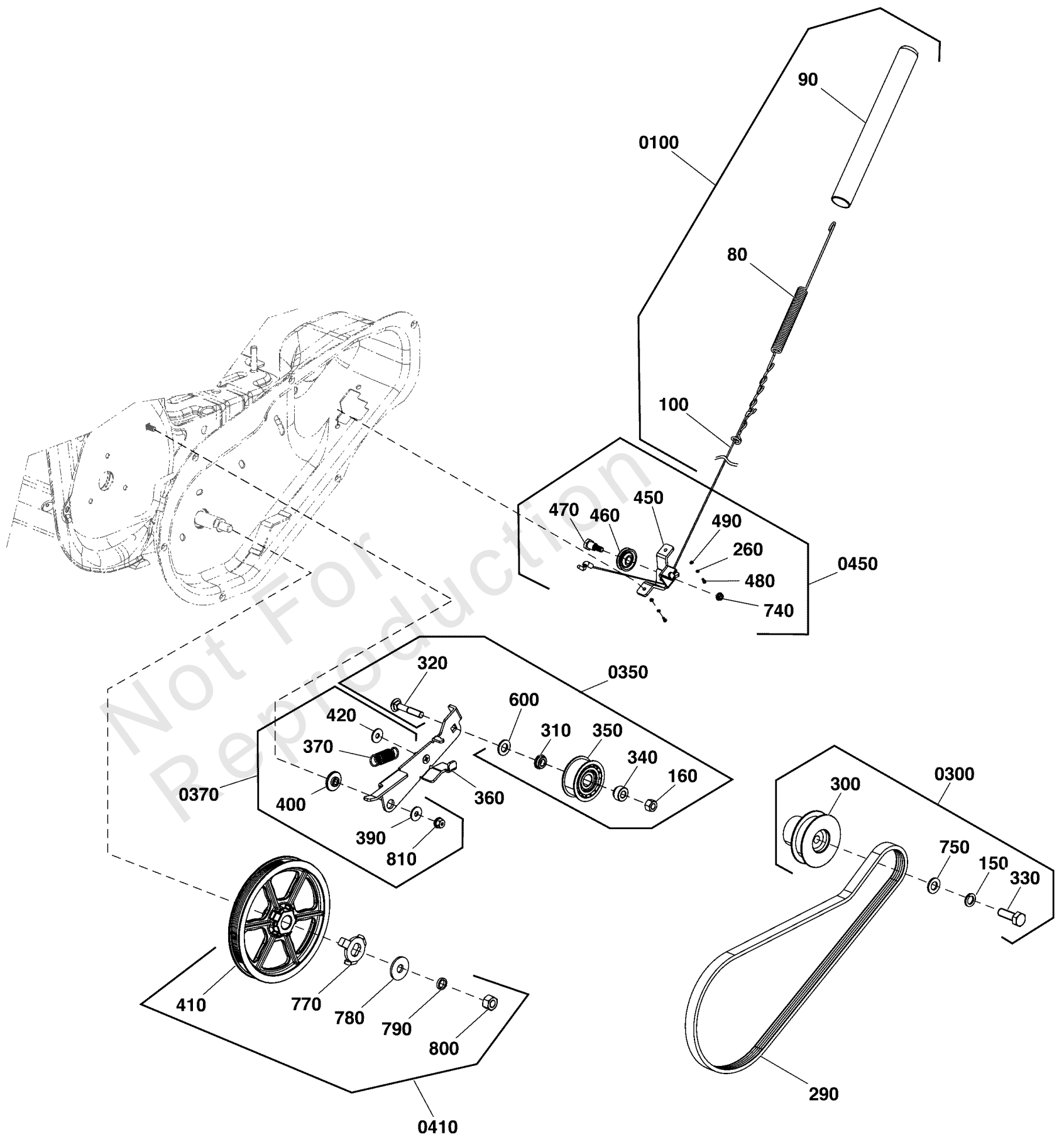

Auger Drive Group

REF NO	PART NO	QTY	DESCRIPTION
290	709868	1	BELT, Drive
360	709927	1	PLATE, Tension
0100	709870	1	KIT, AUGER CABLE -(Incl. Ref. Nos. 80, 90, 100)
80	-----	1	SPRING, Cable
90	-----	1	SLEEVE, Rubber
100	-----	1	CABLE, Auger
0300	709876	1	KIT, ENGINE PULLEY -(Incl. Ref. Nos. 150, 300, 330, 750)
150	-----	1	WASHER, M10, Split Lock
300	-----	1	PULLEY, Driver
330	720016	1	SCREW, 3/8-24 x 1, Hex Head
750	-----	1	WASHER, 10x28x3, Flat
0350	709872	1	KIT, IDLER PULLEY, TENSION PLATE -(Incl. Ref. Nos. 160, 310, 320, 340, 350, 600)
160	-----	1	NUT, M8, Lock
310	-----	1	Spacer, 8.5 ID, 18 OD, 6 Thick, Shoulder
320	-----	1	BOLT, M8x40, Carriage
340	-----	1	SPACER, Idler Pulley
350	-----	1	PULLEY, 8 ID, 53 OD, 22 Wide, Idler
600	-----	1	WASHER, 10x20x1.8, Flat
0370	709874	1	KIT, HARDWARE, IDLER BRACKET -(Incl. Ref. Nos. 370, 390, 400, 420, 810)
370	709869	1	SPRING, Tension
390	-----	1	WASHER, 6 X 18 X 1.5, Flat
400	-----	1	SPACER, Idler Arm
420	-----	1	WASHER, 8x22x2, Flat
810	-----	1	* NUT, M6, Flange Head, Lock
0410	709875	1	KIT, AUGER PULLEY -(Incl. Ref. Nos. 410, 770, 780, 790, 800)
410	-----	1	PULLEY, Driven
770	-----	1	CLAW, Coupling
780	-----	1	WASHER, 10x25x2, Flat
790	-----	1	WASHER, M10, Split Lock
800	-----	1	NUT, Lock, M10
0450	709871	1	KIT, CABLE BASE, AUGER DRIVE -(Incl. Ref. Nos. 260, 450, 460, 470, 480, 490, 740)
260	-----	2	WASHER, M6, Split Lock, MC
450	-----	1	BRACKET, Cable Guide
460	-----	1	PULLEY, Cable
470	-----	1	SCREW, M6 X 12, Hex Head Shoulder
480	7091835	2	SCREW, M6 1.0X12MM, Hex Head, CZ
490	-----	2	WASHER, 6x12x.7, Flat
740	-----	1	NUT, M6, Flange Head

Auger Group

Note: Unless noted otherwise, use the standard torque specifications

Mfg. No: 1697293-00

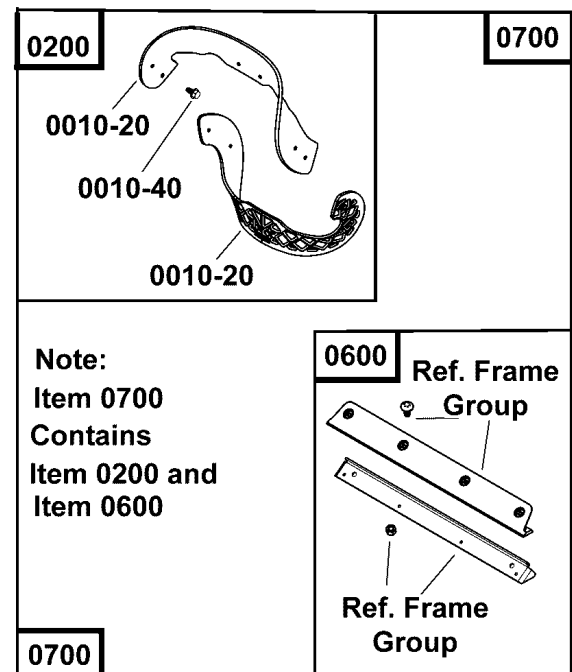
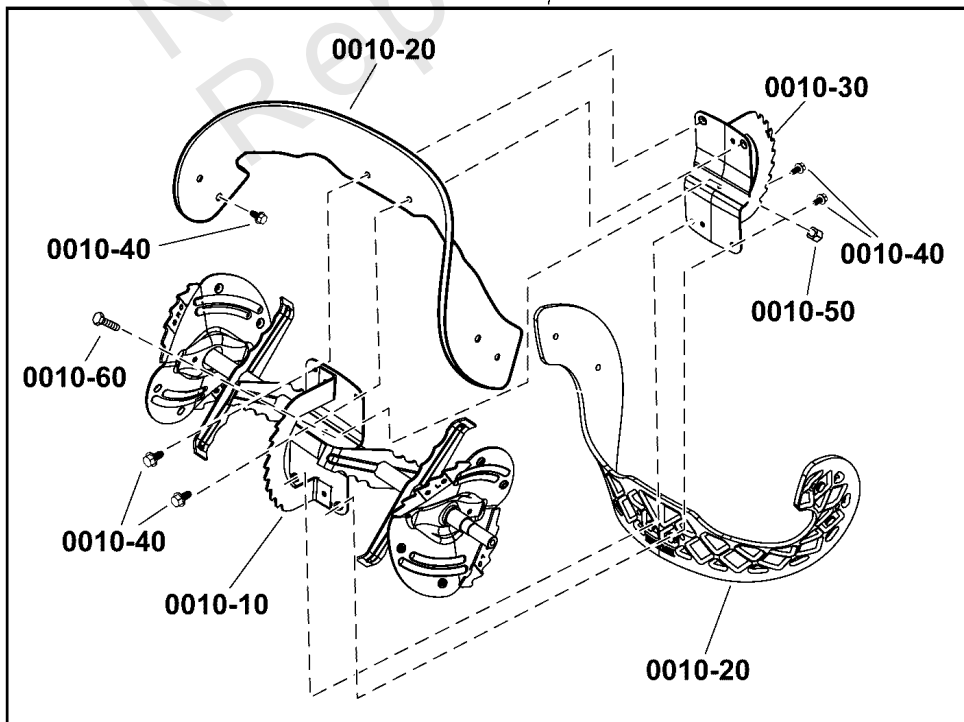
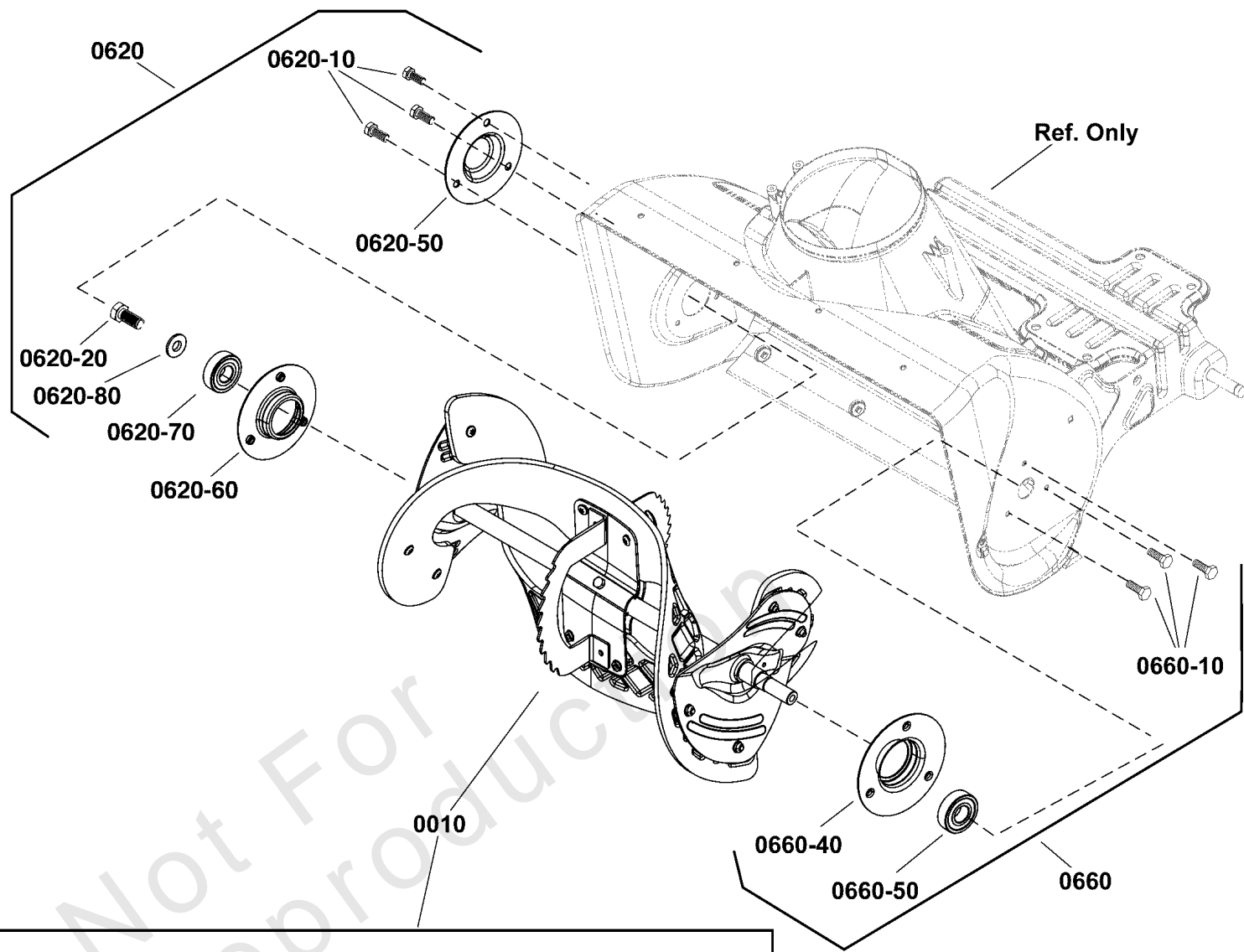

Auger Group

REF NO	PART NO	QTY	DESCRIPTION
0010	84006448	1	AUGER ASSEMBLY, Complete -(Includes Ref. Nos. 0010-10 thru 0010-0060)
0010-10	-----	1	*AUGER SHAFT ASSEMBLY
0010-20	-----	2	**FLIGHT, Auger
0010-30	-----	2	*PLATE, Auger, Center
0010-40	7091246YP	12	SCREW, 1/4-20 x 3/4, Pan Head Torx
0010-50	703232	1	NUT, Hex Lock, 1/4-20, ESNA
0010-60	703234	1	CAPSCREW, Hex Head, 1/4-20 X 1 1/2, G5
0200	1687804	1	KIT, AUGER FLIGHT -(Includes Ref. Nos. 0010-20 & 0010-40)
0600	1687805	1	KIT, Scaper Bar
0660	709878	1	KIT, AUGER BEARING, LEFT -(Incl. Ref. Nos. 0660-10, 0660-40 & 0660-50)
0660-10	7091835YP	3	SCREW, M6 1.0X12MM, Hex Head, CZ
0660-40	-----	1	RETAINER, Bearing
0660-50	-----	1	BEARING
0700	1687806	1	KIT, Auger Flight & Scaper Bar -(Includes Ref. Nos. 0200 & 0600)
0620	709882	1	KIT, AUGER BEARING, RIGHT -(Incl. Ref. Nos. 0620-10, 0620-20, 0620-50 through 0620-80)
0620-10	7091835YP	3	SCREW, M6 1.0X12MM, Hex Head, CZ
0620-20	-----	1	BOLT, M6x16, Hex Head
0620-50	-----	1	CAP, Bearing
0620-60	-----	1	RETAINER, Bearing
0620-70	-----	1	BEARING
0620-80	-----	1	WASHER, 6x23x3, Flat
--	709877	1	KIT, AUGER BEARING -(Includes Ref Nos. 0620-70 & 0660-50)

Footnotes:

Note: ** Not a servicable part, order Auger Flight Kit 1687489YP

Note: * Not a servicable part, order complete Auger Assembly

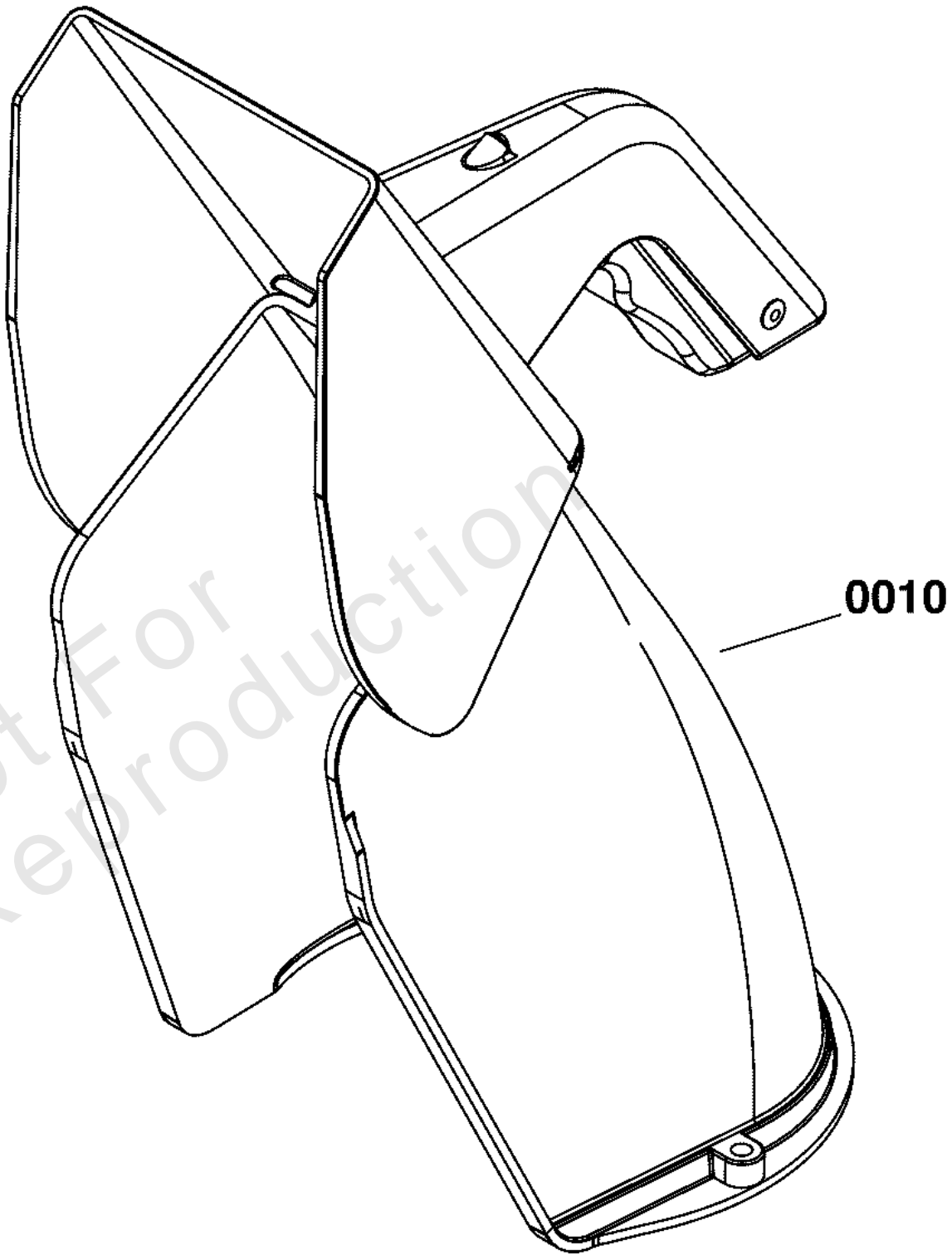

Chute Group

REF NO	PART NO	QTY	DESCRIPTION
0010	709756	1	CHUTE ASSEMBLY, Quick

Not For Reproduction

Chute Rotation Group - Electric

Note: Unless noted otherwise, use the standard torque specifications

Mfg. No: 1697293-00

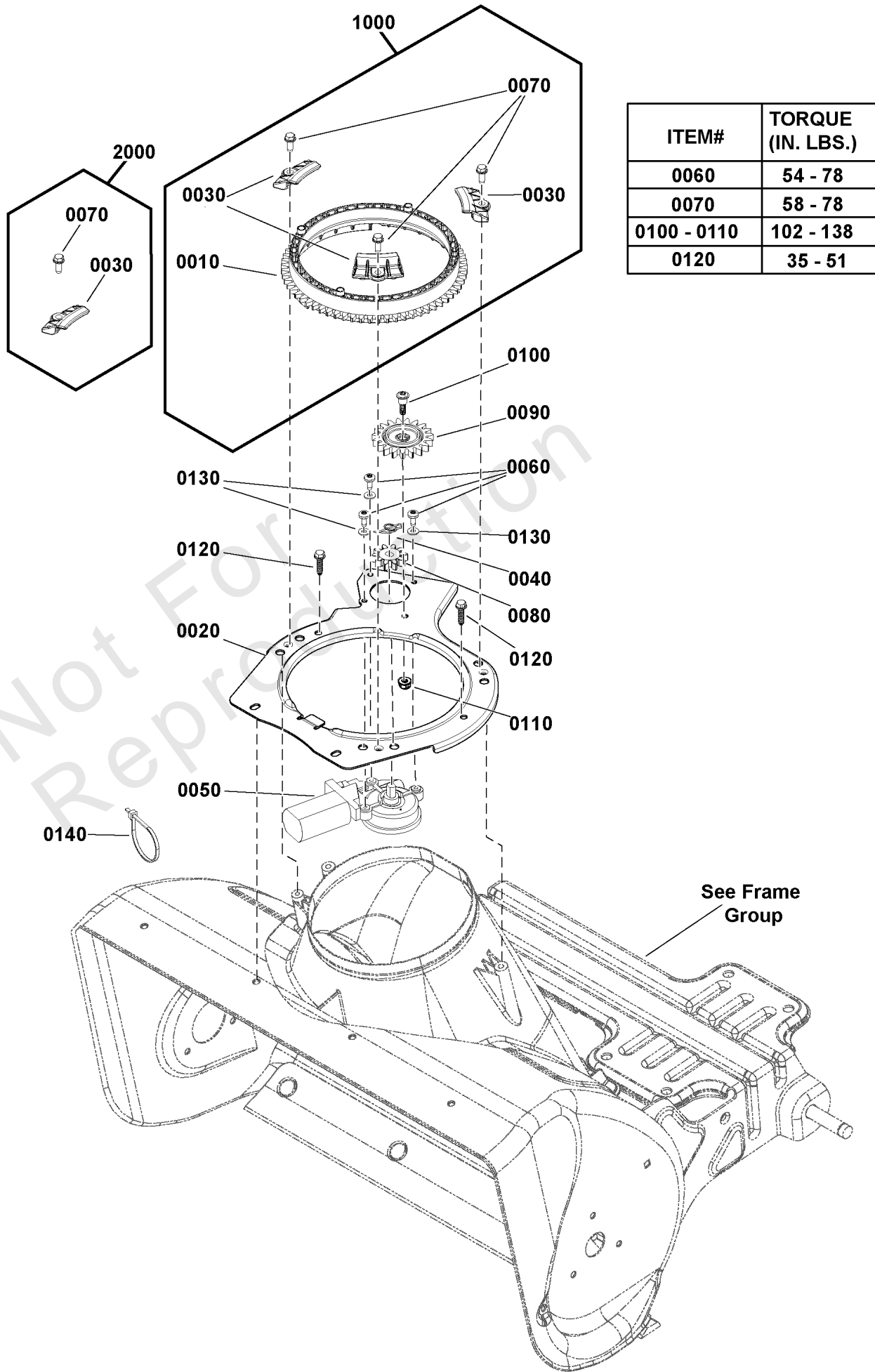

ITEM#	TORQUE (IN. LBS.)
0060	54 - 78
0070	58 - 78
0100 - 0110	102 - 138
0120	35 - 51

Chute Rotation Group - Electric

REF NO	PART NO	QTY	DESCRIPTION
0010	706509	1	GEAR
0020	-----	1	PLATE, Chute Rotation Electric -(Not a serviceable part)
0030	706511	3	RETAINER, CHUTE GEAR
0040	7091594SM	1	PIN, Cotter, 1/2
0050	708703	1	MOTOR, Chute Rotation
0060	1739621YP	3	SCREW, Torx Button Head, M5 x .8 x 14
0070	703054	3	SCREW, Hex Washer Head, 1/4-20 x 5/8
0080	84006454	1	GEAR, 10T
0090	84006455	1	GEAR, 19T
0100	706514	1	SCREW, Shoulder, Button Torx Washer Head, 1/4-20 x 1
0110	703463	1	NUT, Flange Nylock , 1/4-20
0120	706516	2	SCREW, Hi-Low, 1/4-15 x 1
0130	7091552SM	3	WASHER, Flat, 7/32
0140	7024649YP	1	WIRE TIE, 11 Inch Standard Black Nylon
1000	709922	1	KIT, CHUTE GEAR -(Incl. Ref. Nos. 0010, 0030 & 0070)
2000	709923	1	KIT, CHUTE RETAINER -(Incl. Ref. Nos. 0030 & 0070)

Cover & Wheel Group

Note: Unless noted otherwise, use the standard torque specifications

Mfg. No: 1697293-00

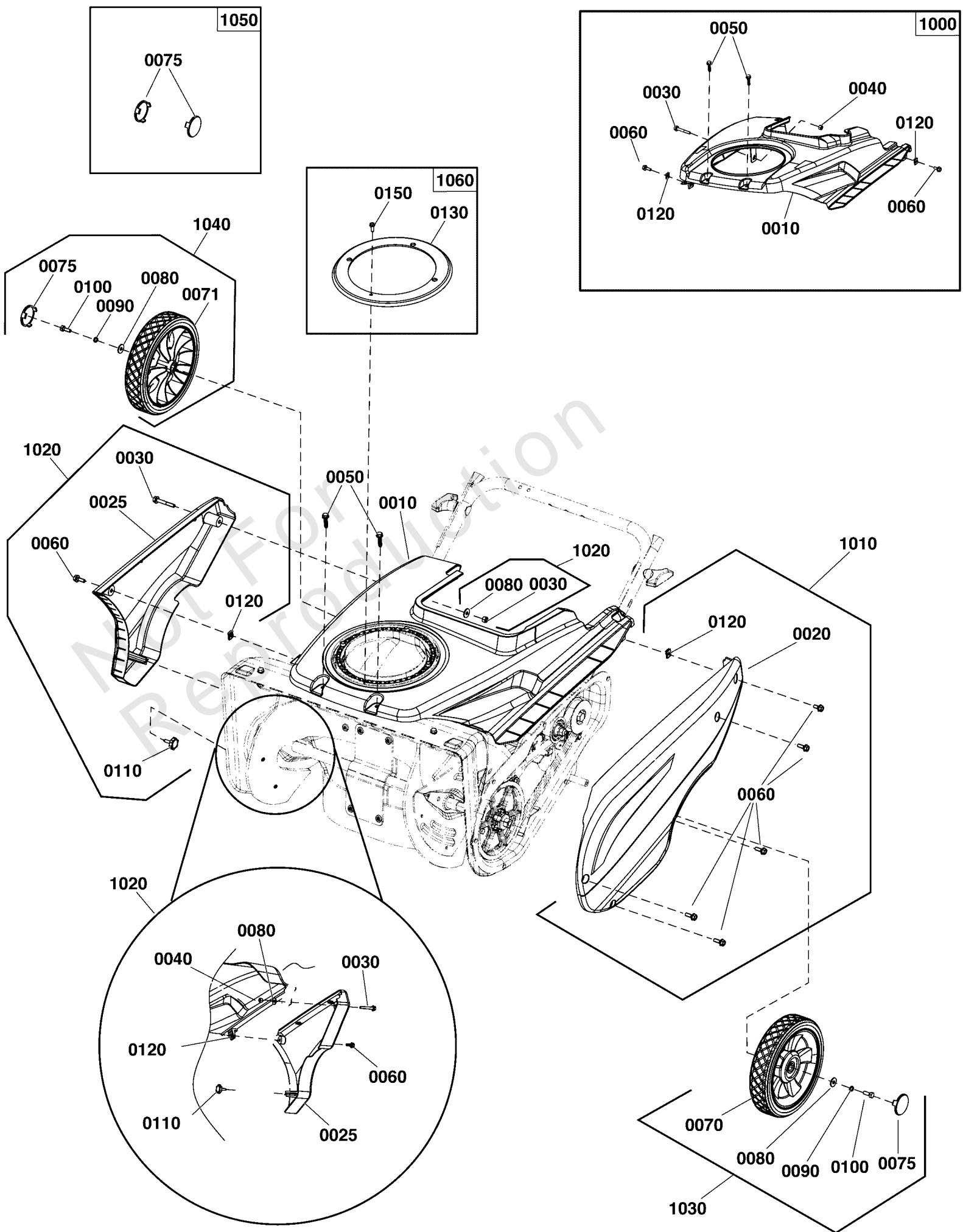

Cover & Wheel Group

REF NO	PART NO	QTY	DESCRIPTION
1000	770586	1	KIT, COVER, Top -(Incl. Ref. Nos. 0010, 0030, 0040, 0050, 0060 & 0120)
0010	-----	1	COVER, Top
0030	-----	1	SCREW, M6x40, Hex Flange Head
0040	-----	1	NUT, M6, Lock
0050	7091081SM	2	SCREW, 1/4-15X3/4, Self-Tapping, BZ
0060	-----	2	SCREW, M6x16, Hex Washer Head
0120	-----	2	NUT, M6, CLIP
1010	709896	1	KIT, DRIVE CASE COVER -(Incl. Ref. Nos. 0020, 0060 & 0120)
0020	-----	1	COVER, Drive Case, Black
0060	-----	7	SCREW, M6x16, Hex Washer Head
0120	-----	1	NUT, M6, CLIP
1020	709916	1	KIT, SIDE COVER, RIGHT -(Incl. Ref. Nos. 0025, 0030, 0040, 0060, 0080,0110 & 0120)
0025	-----	1	COVER, Side, Continuum Charcoal
0030	-----	1	SCREW, M6x40, Hex Flange Head
0040	-----	1	NUT, M6, Lock
0060	-----	2	SCREW, M6x16, Hex Washer Head
0080	-----	1	WASHER, 6 X 18 X 1.5, Flat
0110	-----	1	SCREW, M5x20, Knob, Self-Tapping
0120	-----	2	NUT, M6, CLIP
1030	709885	1	KIT, WHEEL, LEFT, PEWTER -(Incl. Ref. Nos. 0070, 0075, 0080, 0090, 0100)
0070	-----	1	WHEEL, Left, 1.75 X 8, Pewter
0075	-----	1	COVER, End, Wheel, Pewter
0080	-----	1	WASHER, 6 X 18 X 1.5, Flat
0090	-----	1	WASHER, M6, Split Lock, MC
0100	-----	1	BOLT, M6x16, Hex Head
1040	770059	1	KIT, WHEEL, RIGHT, PEWTER -(Incl. Ref. Nos. 0071, 0075, 0080, 0090, 0100)
0070	-----	1	WHEEL, Right, 1.75 X 8, Pewter
0075	-----	1	COVER, End, Wheel, Pewter
0080	-----	1	WASHER, 6 X 18 X 1.5, Flat
0090	-----	1	WASHER, M6, Split Lock, MC
0100	-----	1	BOLT, M6x16, Hex Head
1050	709883	1	KIT, Wheel Cover, Pewter -(Incl. Ref. Nos. 0075)
0075	-----	2	COVER, End, Wheel, Pewter
1060	709887	1	KIT, CHUTE MOISTURE COVER -(Incl. Ref. Nos. 0130 & 0150)
0130	-----	1	COVER, Chute Moisture
0150	316042MA	1	CAPSCREW, Hex Washer Head, #10-HL x 5/8

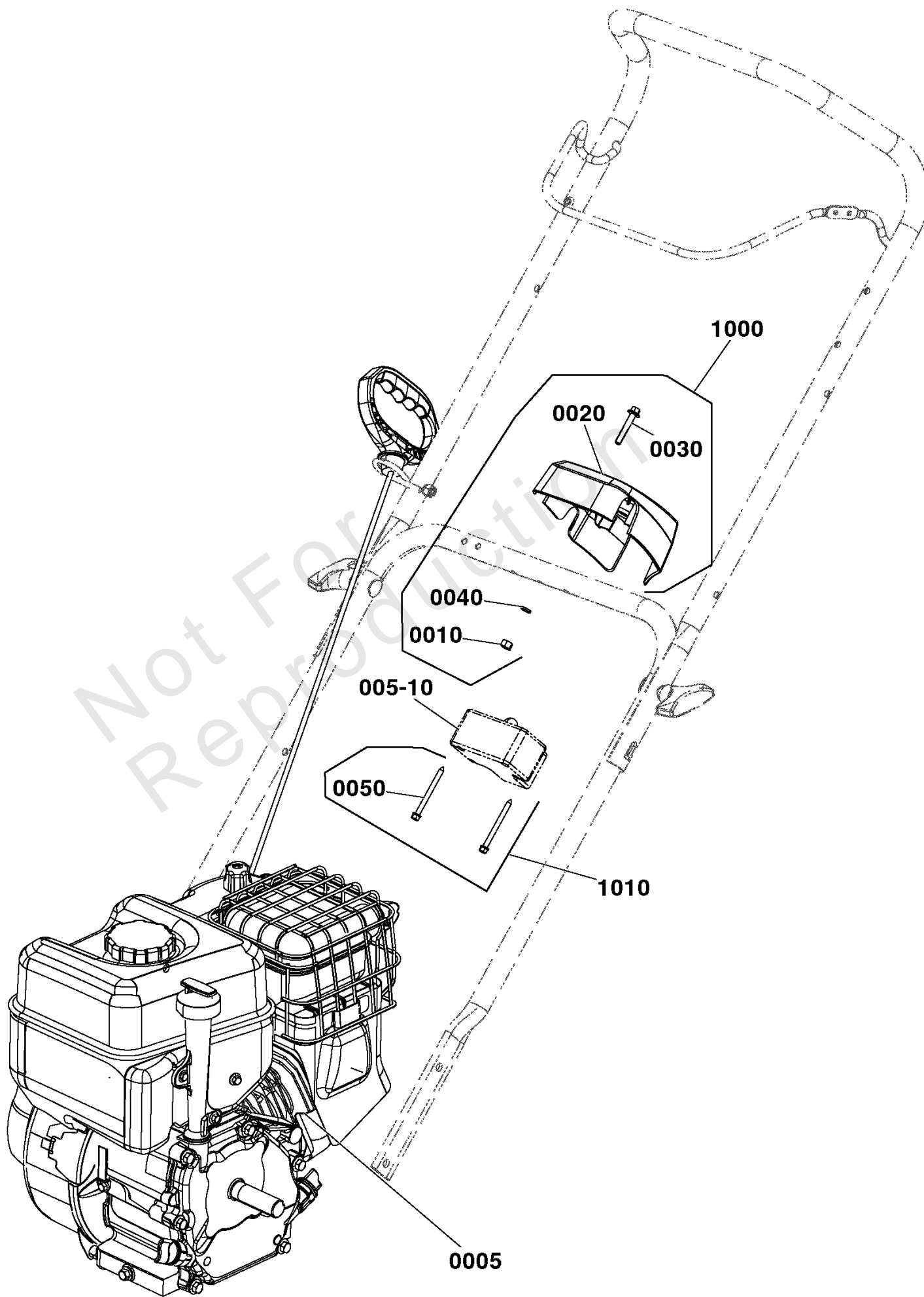

Engine Group

REF NO	PART NO	QTY	DESCRIPTION
0005	15C107-0014-F8	1	* ENGINE, Briggs & Stratton, 11.5 GTP, 1150 Series -(Engine Model: 15C107-0014-F8) (Refer to Note: *)
005-10	591702	1	**MOTOR, Starter -(Refer to Note: **)
1000	709863	1	KIT, STARTER HOUSING -(Incl. Ref. Nos. 0010 through 0040) (For electric start only.)
0010	-----	2	NUT, M6, Lock
0020	1750032YP	1	HOUSING, Starter, 110V
0030	-----	1	SCREW, M6x40, Hex Flange Head
0040	-----	1	WASHER, 6x12x.7, Flat
1010	709864	1	KIT, HARDWARE, STARTER -(Incl. Ref. No. 0050) (For electric start only.)
0050	703066	2	SCREW, 8-16 x 2, Pan Head Phillips, Plast.
--	6219MA	1	CORD, Electric, 10FT. 110V -(Not Illustrated)

Not For
Reproduction

Footnotes:

Note** See your local Briggs & Stratton distributor for parts and service.

Note* To verify your specific engine model, please reference the ID Tag located on your engine. See your local Briggs & Stratton distributor for parts and service.

Handles & Controls Group

Note: Unless noted otherwise, use the standard torque specifications

Mfg. No: 1697293-00

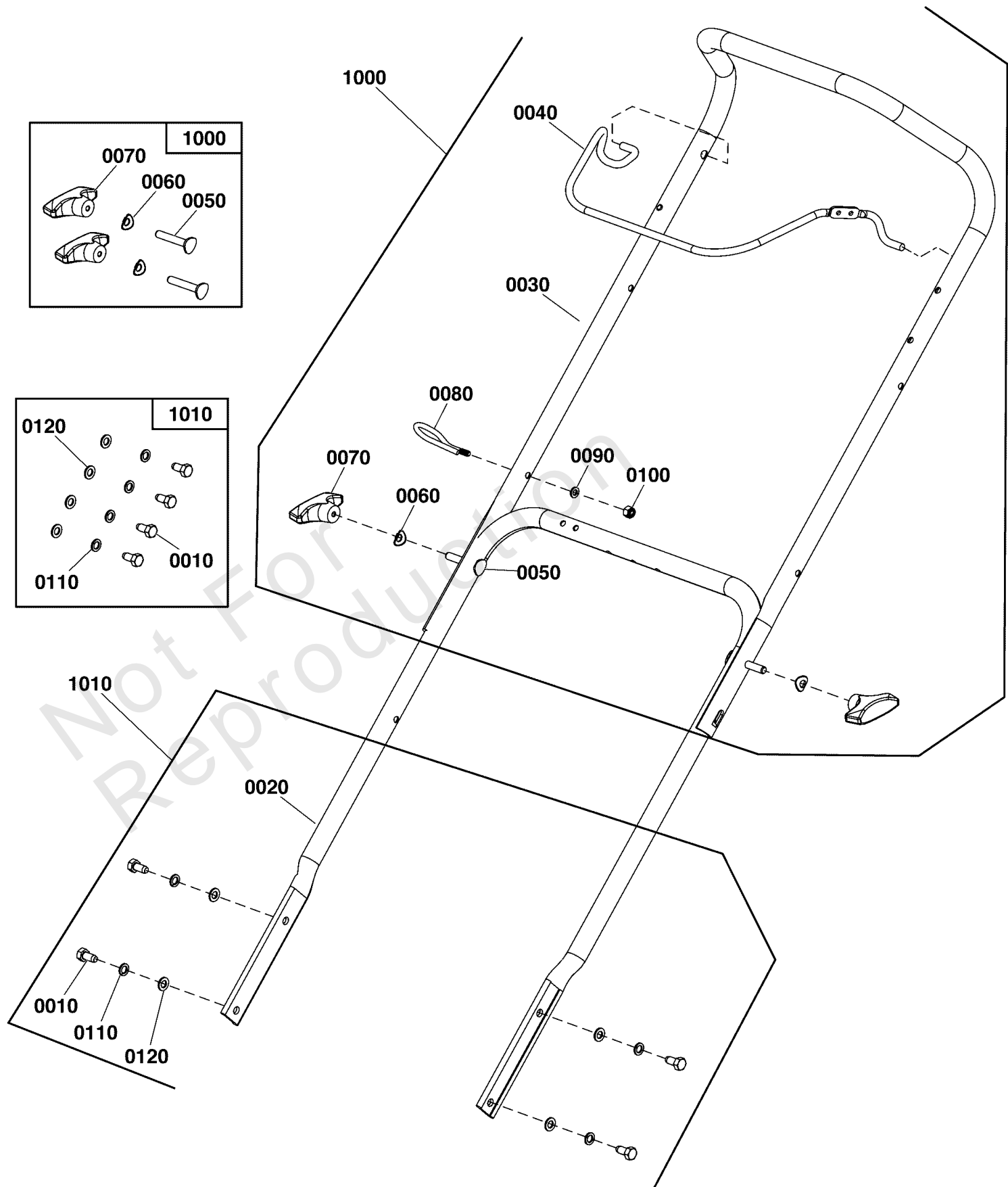

Handles & Controls Group

REF NO	PART NO	QTY	DESCRIPTION
1000	709860	1	KIT, UPPER HANDLE -(Incl. Ref. Nos. 0030 through 0100)
0030	-----	1	HANDLEBAR, Upper SS
0040	709858	1	BAIL, Engine Stop
0050	-----	2	BOLT, M8x40, Carriage, Curved Head
0060	-----	2	WASHER, M8, Curved
0070	-----	2	KNOB, Wing, M8
0080	84002745	1	GUIDE, ROPE
0090	-----	1	WASHER, 6x12x.7, Flat
0100	-----	1	NUT, M6, Lock
1010	709862	1	KIT, LOWER HANDLE -(Incl. Ref. Nos. 0010, 0020, 0110 & 0120)
0010	-----	4	SCREW, Hex Head, M8 X 20
0020	-----	1	HANDLE, Lower
0110	-----	4	WASHER, Lock, M8
0120	-----	4	WASHER, Flat, 8 X 16 X 1.2
1000	709859	2	KIT, UPPER HANDLE HARDWARE -(Incl. Ref. Nos. 0050 through 0070)
0050	-----	2	BOLT, M8x40, Carriage, Curved Head
0060	-----	2	WASHER, M8, Curved
0070	-----	2	KNOB, Wing, M8
1010	709861	1	KIT, LOWER HANDLE HARDWARE -(Incl. Ref. Nos. 0010, 0110 & 0120)
0010	-----	4	SCREW, Hex Head, M8 X 20
0110	-----	4	WASHER, Lock, M8
0120	-----	4	WASHER, Flat, 8 X 16 X 1.2

Light Panel Group

Note: Unless noted otherwise, use the standard torque specifications

Mfg. No: 1697293-00

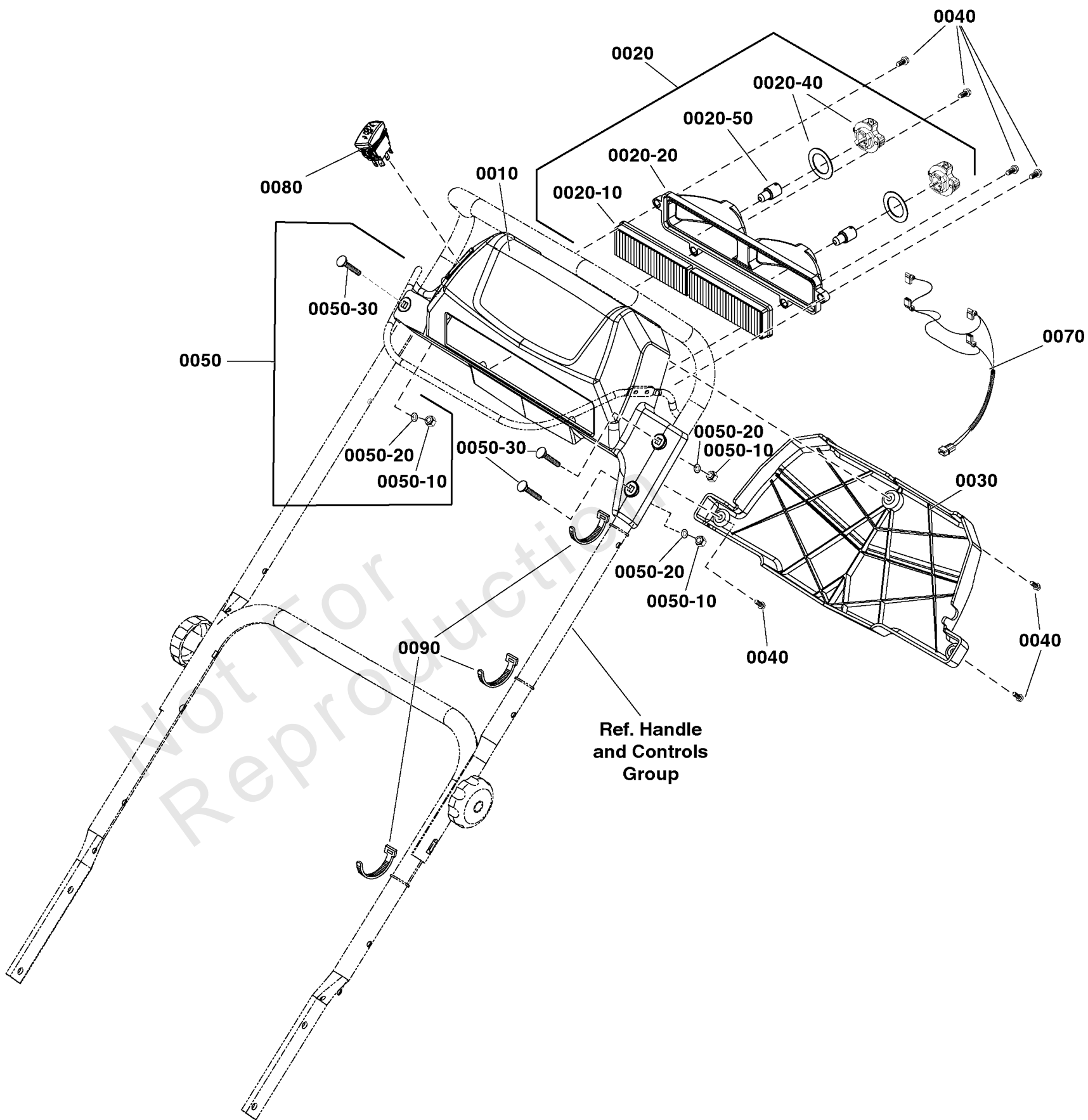

Light Panel Group

REF NO	PART NO	QTY	DESCRIPTION
0010	708157	1	PANEL
0020	84006433	1	HEADLIGHT ASSEMBLY -(Includes Ref. Nos. 0020-10, 0020-20, 0020-40, 0020-50)
0020-10	1736177YP	1	LENS, Twin Light
0020-20	1736178YP	1	DEFLECTOR
0020-40	1736180YP	2	SOCKET & GASKET ASSEMBLY, Headlight
0020-50	84006434	2	LIGHT, LED, 6W
0030	706481	1	COVER, Light Panel
0040	7091105YP	7	SCREW, Hex Washer Head, #10-16 x 1/2
0050	84006458	1	HARDWARE BAG -(Includes Ref. Nos. 0050-10, 0050-20, 0050-30)
0050-10	-----	3	NUT, Lock, M6
0050-20	-----	3	WASHER, 6x12x.7, Flat
0050-30	-----	3	BOLT, M6x35
0070	708158	1	HARNESS, Wiring with Remote Rectifier
0080	1754865YP	1	SWITCH, Chute Rotation
0090	7024649YP	4	WIRE TIE, 11 Inch Standard Black Nylon

Not For Reproduction

Hardware Identification & Torque Specifications

Torque Specification Chart								
FOR STANDARD METRIC MACHINE HARDWARE (Tolerance ± 20%)								
Property Class	5.6		8.8		10.9		12.9	
	Class 5.6		Class 8.8		Class 10.9		Class 12.9	
Size Of Hardware	in/lbs	Nm.	in/lbs	Nm.	in/lbs	Nm.	in/lbs	Nm.
	ft/lbs		ft/lbs		ft/lbs		ft/lbs	
M3	5.88	.56	13.44	1.28	19.2	1.80	22.92	2.15
M4	13.44	1.28	30.72	2.90	43.44	4.10	52.56	4.95
M5	26.4	2.50	60.96	5.75	5.97	8.10	7.15	9.7
M6	44.64	4.3	7.3	9.9	10.3	14	12.1	16.5
M7	5.2	7.1	12.1	16.5	16.9	23	19.9	27
M8	7.7	10.5	17.7	24	25	34	29	40
M10	15	21	35	48	50	67	59	81
M12	26	36	61	83	86.2	117	103	140
M14	42	58	101	132	136	185	162	220
M16	64	88	147	200	210	285	250	340
M18	89	121	202	275	287	390	346	470
M20	126	171	290	390	405	550	486	660
M22	169	230	390	530	559	745	656	890
M24	217	295	497	375	708	960	840	1140
M27	320	435	733	995	1032	1400	1239	1680
M30	435	590	995	1350	1401	1900	1681	2280
M33	590	800	1349	1830	1902	2580	2278	3090
M36	759	1030	1740	2360	2441	3310	2935	3980
M39	988	1340	2249	3050	3163	4290	3798	5150

Torque Specification Chart						
FOR STANDARD MACHINE HARDWARE (Tolerance ± 20%)						
Hardware Grade	No Marks		SAE Grade 5		SAE Grade 8	
	SAE Grade 2		SAE Grade 5		SAE Grade 8	
Size Of Hardware	in/lbs	Nm.	in/lbs	Nm.	in/lbs	Nm.
	ft/lbs		ft/lbs		ft/lbs	
8-32	19	2.1	30	3.4	41	4.6
8-36	20	2.3	31	3.5	43	4.9
10-24	27	3.1	43	4.9	60	6.8
10-32	31	3.5	49	5.5	68	7.7
1/4-20	66	7.6	8	10.9	12	16.3
1/4-28	76	8.6	10	13.6	14	19.0
5/16-18	11	15.0	17	23.1	25	34.0
5/16-24	12	16.3	19	25.8	29	34.0
3/8-16	20	27.2	30	40.8	45	61.2
3/8-24	23	31.3	35	47.6	50	68.0
7/16-14	30	40.8	50	68.0	70	95.2
7/16-20	35	47.6	55	74.8	80	108.8
1/2-13	50	68.0	75	102.0	110	149.6
1/2-20	55	74.8	90	122.4	120	163.2
9/16-12	65	88.4	110	149.6	150	204.0
9/16-18	75	102.0	120	163.2	170	231.2
5/8-11	90	122.4	150	204.0	220	299.2
5/8-18	100	136	180	244.8	240	326.4
3/4-10	160	217.6	260	353.6	386	525.0
3/4-16	180	244.8	300	408.0	420	571.2
7/8-9	140	190.4	400	544.0	600	816.0
7/8-14	155	210.8	440	598.4	660	897.6
1-8	220	299.2	580	788.8	900	1,244.0
1-12	240	326.4	640	870.4	1,000	1,360.0

The guides and ruler furnished below are designed to help you select the appropriate hardware.



Nut, M8

Thread Diameter (mm)

Inside Diameter (in) Threads per inch

Nut, 1/2-16

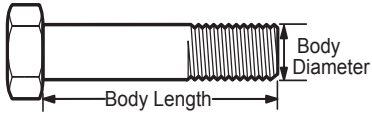

Screw, M8- 1.25 x 25

Thread Diameter (mm) Distance between threads (mm) Body Length (mm)

Body Diameter Threads per inch Body Length (in)

Screw, 1/2- 16 x 2



Standard Hardware Sizing

When a washer or nut is identified as 1/2" (M8), this is the *Nominal size*, meaning the *inside diameter* is 1/2 inch (8mm metric thread diameter); if a second number is present it represents the *threads per inch* (distance between threads).

When bolt or capscrew is identified as 1/2 - 16 x 2" (M8 - 1.25 x 50), this means the *Nominal size*, or body diameter is 1/2 inch (8mm metric thread diameter), the second number, 16, represents the *threads per inch*, (*distance between threads*). The final number is the body length of the bolt or screw, 2 inches (50mm).

NOTES

- These torque values are to be used for all hardware excluding: locknuts, self-tapping screws, thread forming screws, sheet metal screws and socket head setscrews.
- Recommended seating torque values for locknuts:
 - for prevailing torque locknuts - use 65% of grade 5 torques.
 - for flange whizlock nuts and screws - use 135% of grade 5 torques.
- Unless otherwise noted on assembly drawings, all torque values must meet this specification.

Common Hardware Types

Hex Head Capscrew



Washer



Carriage Bolt



Hex Nut

Wrench & Fastener Size Guide

1/4" Bolt or Nut Wrench—7/16"	5/16" Bolt or Nut Wrench—1/2"	3/8" Bolt or Nut Wrench—9/16"	7/16" Bolt or Nut Wrench (Bolt)—5/8" Wrench (Nut)—11/16"	1/2" Bolt or Nut Wrench—3/4"
M6 Bolt or Nut Wrench—10mm	M8 Bolt or Nut Wrench—13mm	M10 Bolt or Nut Wrench—17mm	M12 Bolt or Nut Wrench—19mm	M14 Bolt or Nut Wrench—22mm

