



Parts Manual

Mfg. No: 1696507-00
1222EED, B&S 11.5 Gross TP 22" Single

Model Components	Page
Auger Drive Group.....	4
Auger Group.....	6
Chute Group - Electric.....	8
Chute Rotation Group - Electric.....	10
Decals Group.....	12
Engine Group.....	14
Frame Group.....	16
Handles & Controls Group - Electric.....	18
Light Panel Group.....	20
Wheel & Body Covering Group.....	22
Torque Specification Chart.....	24

Not For
Reproduction

Auger Drive Group

Note: Unless noted otherwise, use the standard torque specifications

Mfg. No: 1696507-00

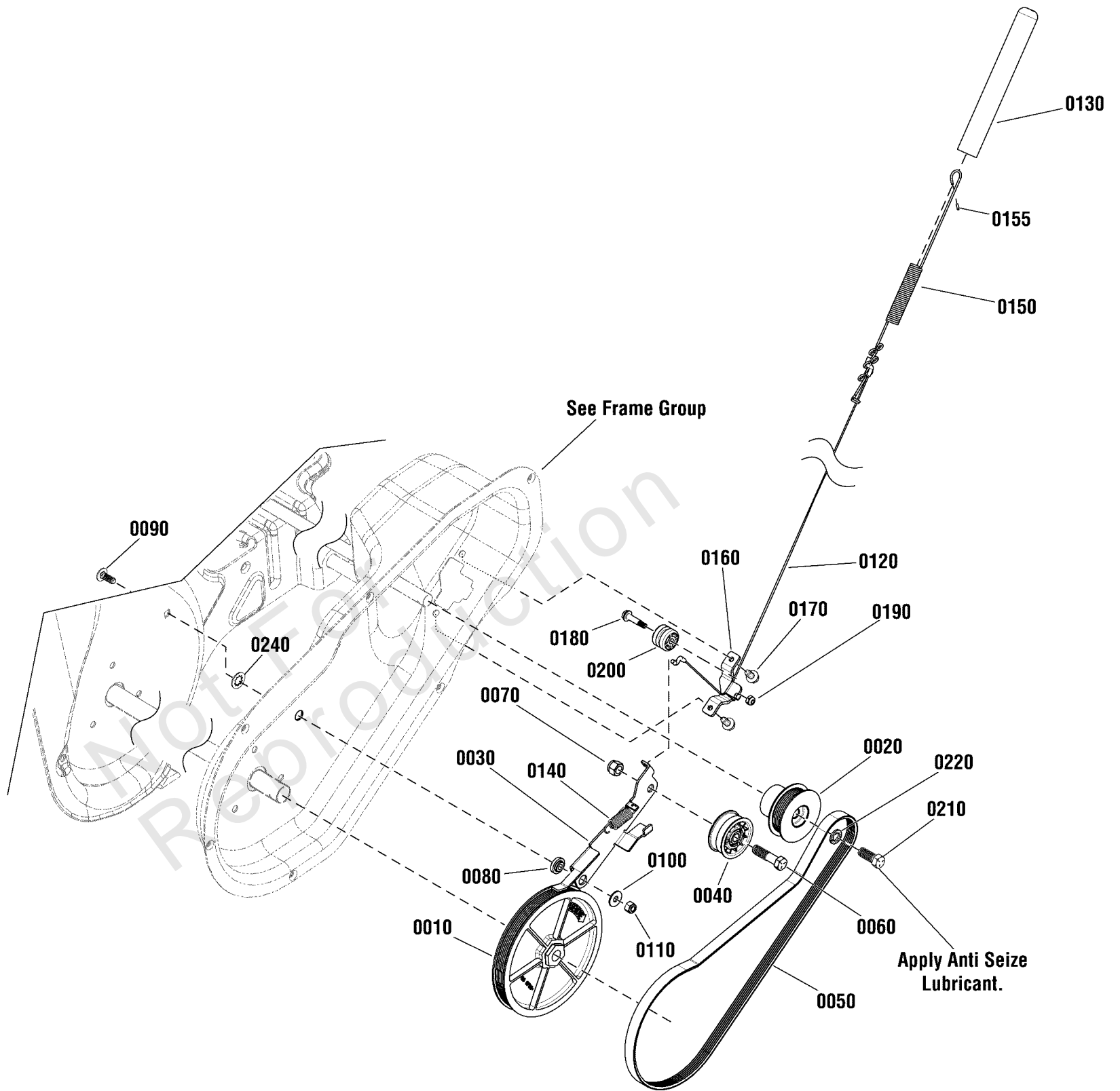

Auger Drive Group

REF NO	PART NO	QTY	DESCRIPTION
0010	1739730YP	1	PULLEY, Driven
0020	1739179YP	1	PULLEY, Driver
0030	1739526YP	1	ARM, Idler, Drive
0040	1502120MA	1	IDLER, Plastic Ball Bearing
0050	1739338YP	1	BELT, Drive
0060	01X111MA	1	CAPSCREW, Hex Head, 3/8-16 x 1-1/2
0070	7091299SM	1	NUT, Nylock, 3/8
0080	1739709YP	1	SPACER, Idler Arm
0090	1931318SM	1	BOLT, Carriage, Short Neck, 1/4-20 x 7/8 G5
0100	7091253YP	1	WASHER, Flat, .281 X 3/4 x 1/2
0110	7091603SM	1	NUT, Nylock, 1/4
0120	1502113MA	1	CABLE, Handle
0130	1739935YP	1	BOOT, Clutch Spring
0140	1750226YP	1	SPRING, Idler
0150	1750315YP	1	SPRING, Extension
0155	704137	1	COVER, Spring End
0160	1750329YP	1	BRACKET, Cable Guide
0170	1750447YP	2	SCREW, Hex Washer Head, Trilob, 1/4-20 x 1/2
0180	1750594YP	1	CAPSCREW, Hex Shoulder, 1/4 x 3/4
0190	7090376YP	1	NUT, Locking, #10
0200	579860MA	1	SPOOL CABLE, Auger Control
0210	001X20MA	1	CAPSCREW, Hex Head, 3/8-24 x 1
0220	22237GS	1	WASHER, Locking, 3/8
0240	1960518SM	1	NUT, Push, 1/4

Auger Group

Note: Unless noted otherwise, use the standard torque specifications

Mfg. No: 1696507-00

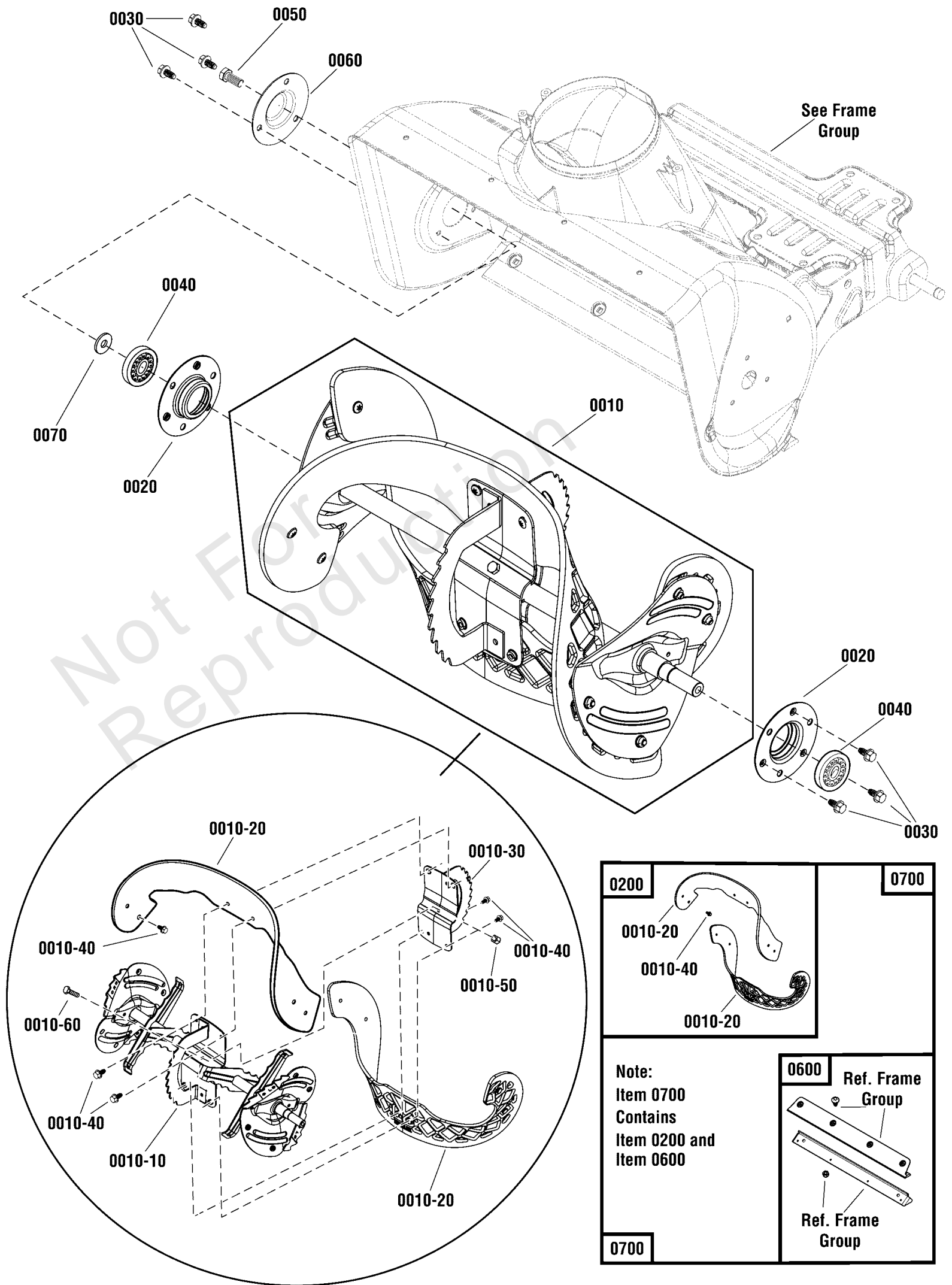

Auger Group

REF NO	PART NO	QTY	DESCRIPTION
0010	1687814	1	AUGER ASSEMBLY, Complete -(Incl. Ref. Nos. 0010-10, 0010-20, 0010-30, 0010-40, 0010-50 & 0010-60)
0010-10		1	* AUGER SHAFT ASSEMBLY
0010-20		2	** FLIGHT, Auger -(Included with Ref. No. 0200)
0010-30		2	* PLATE, Auger, Center
0010-40	7091246YP	12	SCREW, Pan Head Torx, 1/4-20 x 3/4 -(Included with Ref. No. 0200)
0010-50	7091603SM	1	NUT, Nylock, 1/4-20
0010-60	703234	1	CAPSCREW, Hex Head, 1/4-20 X 1 1/2, G5
0020	1739228YP	2	RETAINER, Bearing
0030	1750447YP	6	SCREW, Hex Washer Head, Trilob, 1/4-20 x 1/2
0040	1705897SM	2	BEARING, Ball, 11/16 x 1-9/16 x 15/32
0050	704287	1	CAPSCREW, Hex Head, 5/16-18 x 3/4
0060	1739229AYP	1	CAP, BEARING
0070	7900022YP	1	WASHER, Flat, 7/8 x 21/64
0200	1687489YP	1	KIT, Auger Flight -(Incl. Ref. Nos. 0030 & 0010-40)
0600	1687805	1	KIT, Scraper Bar -(Reference Frame group)
0700	1687806	1	KIT, Scraper Bar & Flight -(Incl. Ref. Nos. 0200 & 0600)

Not For
Reproduction

Footnotes:

** Not a servicable part, order Auger Flight Kit.

* Not a servicable part, order complete Auger Assembly.

Chute Group - Electric

Note: Unless noted otherwise, use the standard torque specifications

Mfg. No: 1696507-00

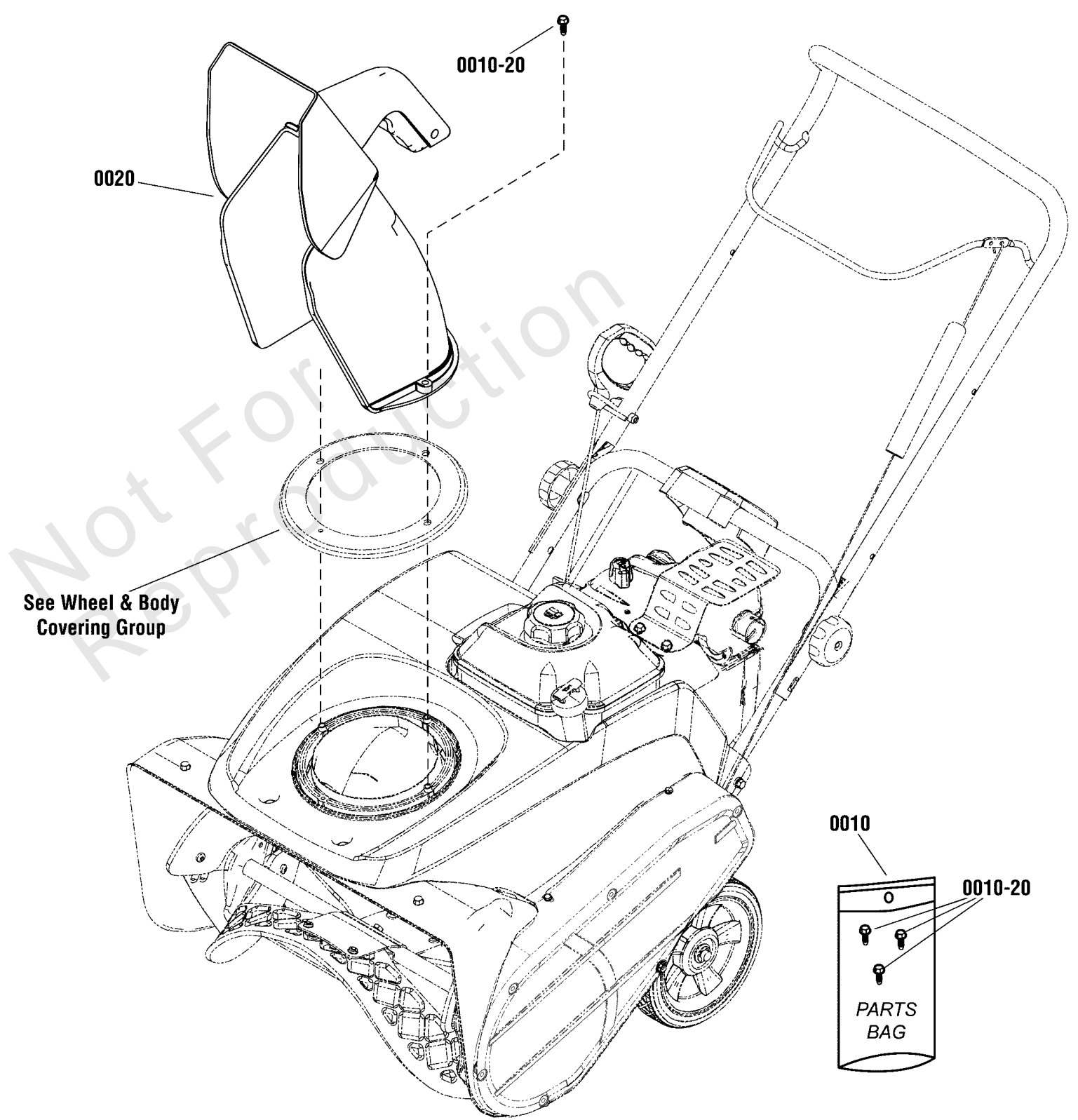

Chute Group - Electric

REF NO	PART NO	QTY	DESCRIPTION
0010	1751006YP	1	PARTS BAG
0010-20	1751399YP	3	SCREW, Hex Washer Head, HI-LO, 1/4-15 x 1-1/4
0020	1739522YP	1	CHUTE ASSEMBLY

Not For
Reproduction

Chute Rotation Group - Electric

Note: Unless noted otherwise, use the standard torque specifications

Mfg. No: 1696507-00

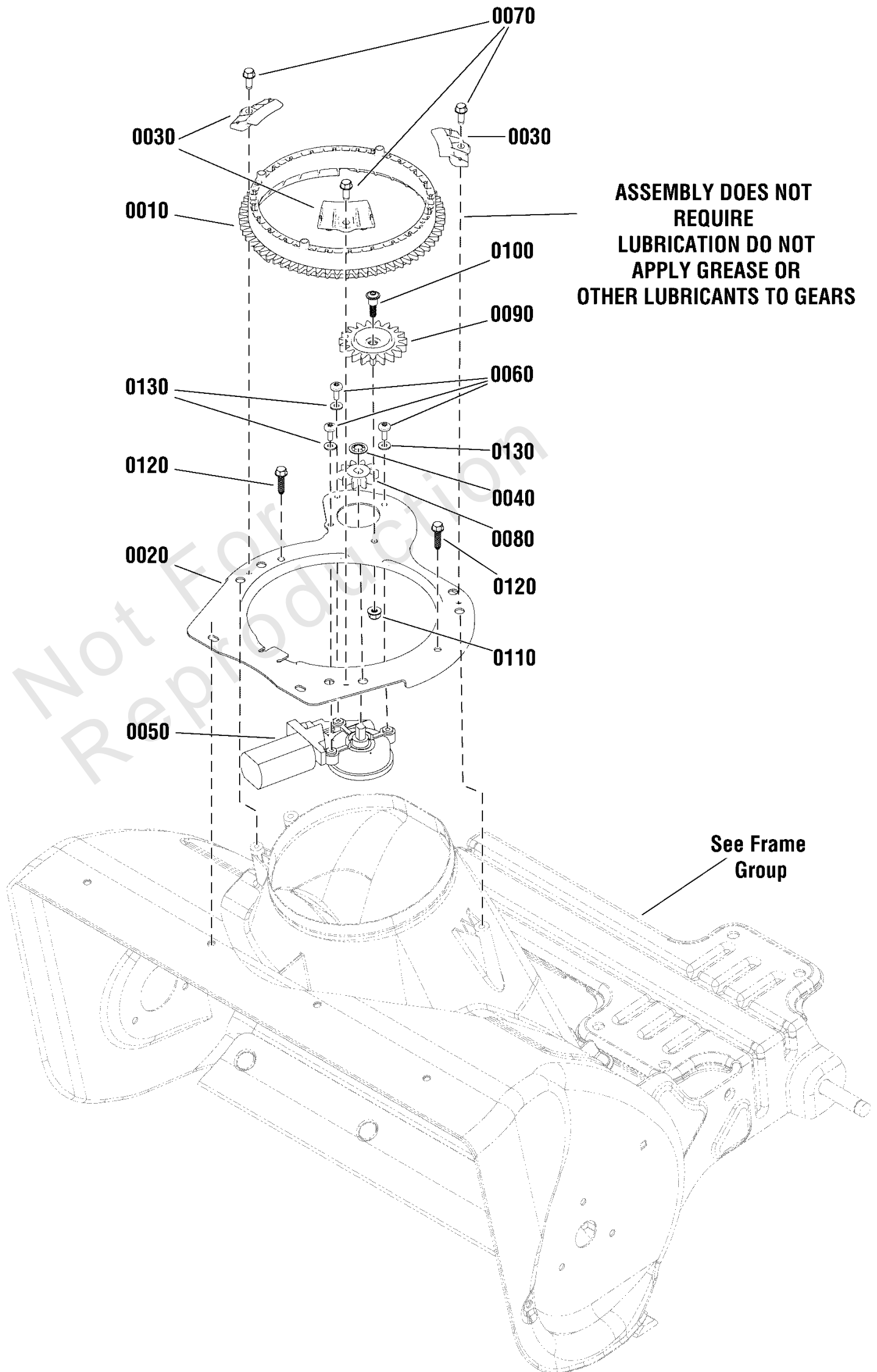

Chute Rotation Group - Electric

REF NO	PART NO	QTY	DESCRIPTION
0010	706509	1	GEAR, Chute Rotation
0020	706510	1	PLATE, Chute Mounting
0030	706511	3	RETAINER, Chute Gear
0040	7013946YP	1	RETAINER, Wheel
0050	1739309YP	1	MOTOR, Chute Rotation
0060	1739621YP	3	SCREW, Torx Button Head, M5 x .8 x 14
0070	703054	3	SCREW, Hex Washer Head, Taptite, 1/4-20 x 5/8
0080	706512	1	GEAR, 10T
0090	706513	1	GEAR, 19T
0100	706514	1	SCREW, Shoulder Button Washer Head, 1/4-20 x 1.00
0110	703463	1	NUT, Hex Nylock Flange, 1/4-20
0120	706516	2	SCREW, High-Low, 1/4-15 x 1.00
0130	7091552SM	3	WASHER, Flat, 1/4

Not For
Reproduction

⚠ DANGER		
Shut off engine and remove key before performing maintenance or repair work.		Arrêter le moteur et retirer la clé avant d'effectuer tout entretien ou toute réparation.
Read the operator's manual for operating and safety instructions.		Lire les consignes de sécurité et d'utilisation dans le manuel d'utilisation.
Thrown Objects Hazard • Never direct discharge chute towards persons or property.		Danger objets projetés • Ne jamais diriger la chute en direction des personnes ou biens matériels.
Amputation Hazard • Contact with auger will cause serious injury. • Keep hands, feet and clothing away. • Keep bystanders away.		Risque d'amputation • Tout contact avec la tarière provoquera de graves blessures. • Tenir vos pieds, vos mains et vêtements à distance. • Tenir les spectateurs à distance.
<small>This spark ignition system complies with the Canadian standard K25-022. Ce système d'allumage par étincelle de véhicule est conforme à la norme NMB-022 du Canada.</small>		

0010

⚠ DANGER	
Amputation hazard	
Contact with moving parts inside chute will cause serious injury.	
• Shut off engine before unclogging discharge chute.	
• Use clean-out tool, not hands!	
Risque d'amputation	
Tout contact avec des pièces en mouvement à l'intérieur de la goulotte provoquera de graves blessures.	
• Arrêter le moteur avant de dégager la goulotte d'éjection.	
• Utiliser l'outil de dégagement, pas les mains!	
<small>1737885</small>	

0020

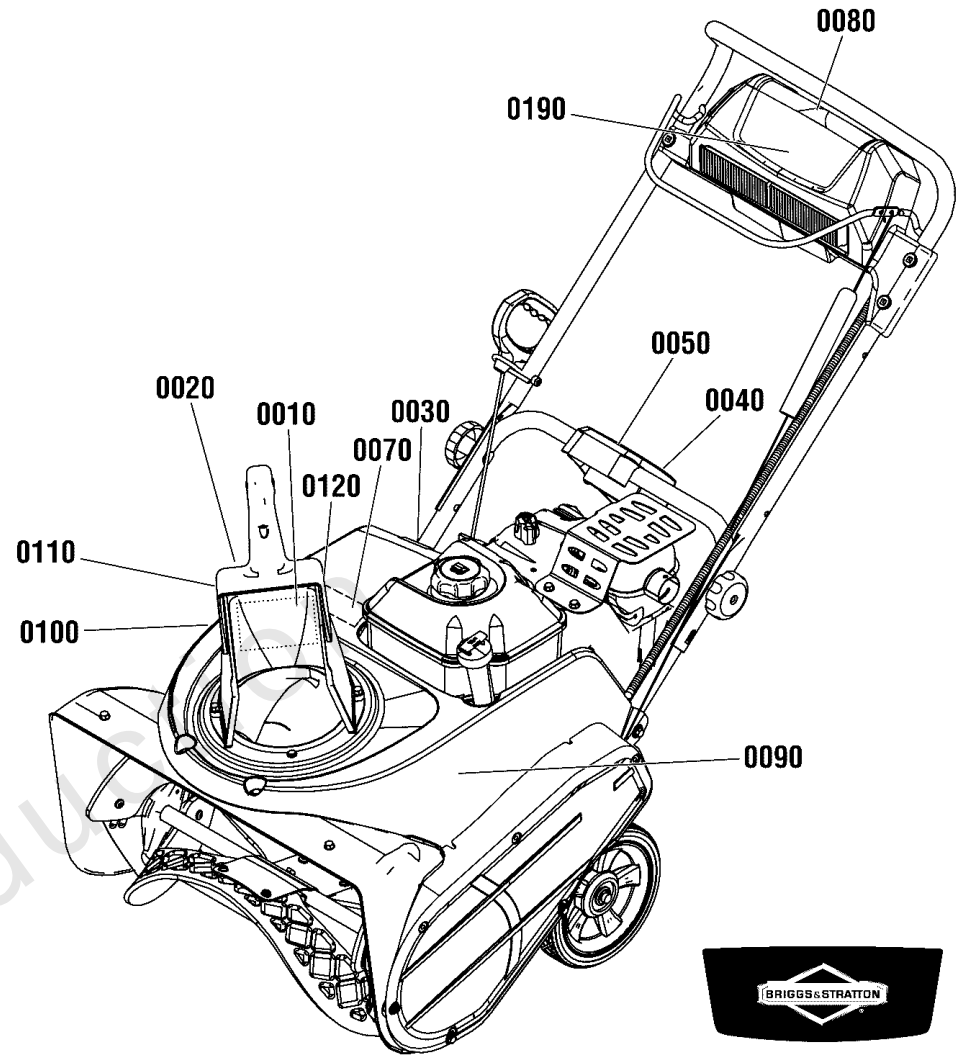

0190

STEPS TO EASY STARTING
ÉTAPES POUR UN DÉMARRAGE FACILE

1 Turn engine ON
Mettez le moteur sur « ON » (marche)

2 Turn choke knob to CHOKE
Tournez le bouton de l'étrangleur sur « CHOKE »

3 For COLD engine PRIME 2X
Si le moteur est FROID amorcez-le 2 fois

4 After engine starts, turn to RUN
Une fois le moteur en marche, mettez-le sur « RUN »

0030

4 Plug in extension cord or Pull rope
Branchez le cordon d'extension ou tirez la corde

0040

5 Push Button to Start
Appuyez sur le bouton pour démarrer

0050

0060



0080



0070



0100



0130

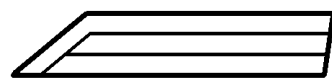

0110

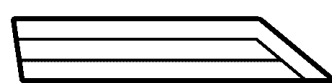

0120



0090

Decals Group

REF NO	PART NO	QTY	DESCRIPTION
0010	1739966YP	1	DECAL, Chute, FR/ENG
0020	1737865YP	1	DECAL, Danger, Chute, FR/ENG
0030	1739970YP	1	DECAL, Step 1-2-3
0040	1750734YP	1	DECAL, 4 Start, FR/ENG
0050	1750736YP	1	DECAL, 5 Start, FR/ENG
0060	1739977YP	1	DECAL, Bail Engagement
0070	706789	1	DECAL, Briggs & Stratton, 1222EE
0080	1754514YP	1	DECAL, Light Bar
0090	706544	1	DECAL, Briggs & Stratton, LH
0100	706543	1	DECAL, Briggs & Stratton, RH
0110	1750658YP	1	DECAL, Logo, Chute, RH
0120	1750657YP	1	DECAL, Logo, Chute, LH
0130	1754247YP	1	DECAL, Assembled in USA
0190	706788	1	DECAL, Briggs & Stratton Logo

Not For
Reproduction

Engine Group

Note: Unless noted otherwise, use the standard torque specifications

Mfg. No: 1696507-00

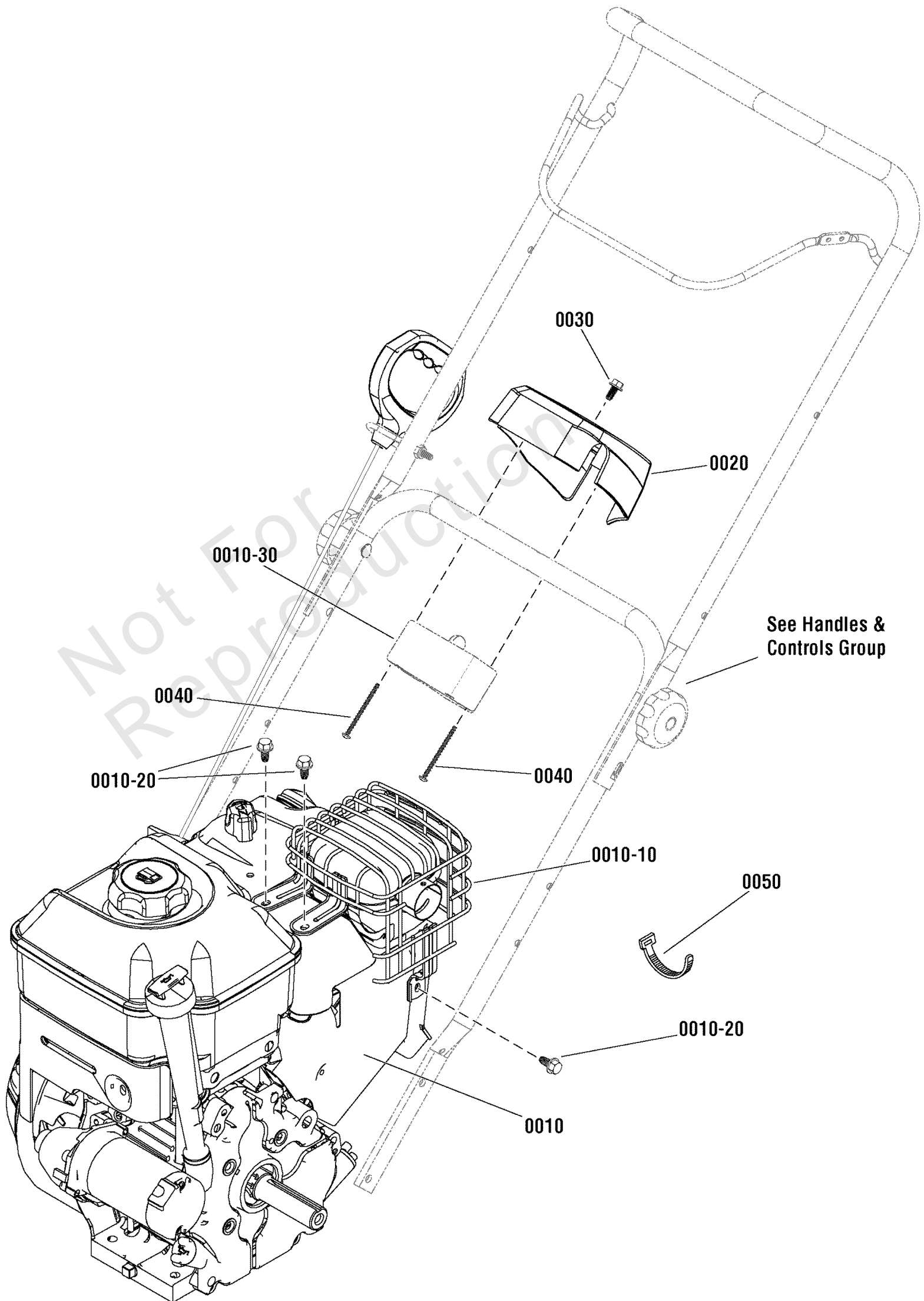

Engine Group

REF NO	PART NO	QTY	DESCRIPTION
0010	15C107-0003-F8	1	* ENGINE, 11.5TP Briggs & Stratton -(Engine Model: 15C107-0003-F8)
0010	15C107-0014-F8	1	* ENGINE, 11.5TP Briggs & Stratton -(Engine Model: 15C107-0014-F8)
0010-10	797003	1	GUARD, Muffler, Plate
0010-20	699854	3	SCREW, Muffler Guard, Hex Washer Head
0010-30		1	** STARTER, 110V
0020	1750032YP	1	HOUSING, Starter, 110V
0030	1750447YP	1	SCREW, Hex Washer Head, Trilob, 1/4-20 x 1/2
0040	1750593YP	2	SCREW, Pan Head Phillips, Plast., 8-16 x 2-1/8
0050	032618MA	4	STRAP, Tie

Not For
Reproduction

Footnotes:

Note** See your local Briggs & Stratton distributor for parts and service.

Note* To verify your specific engine model, please reference the ID Tag located on your engine. See your local Briggs & Stratton distributor for parts and service.

Frame Group

Note: Unless noted otherwise, use the standard torque specifications

Mfg. No: 1696507-00

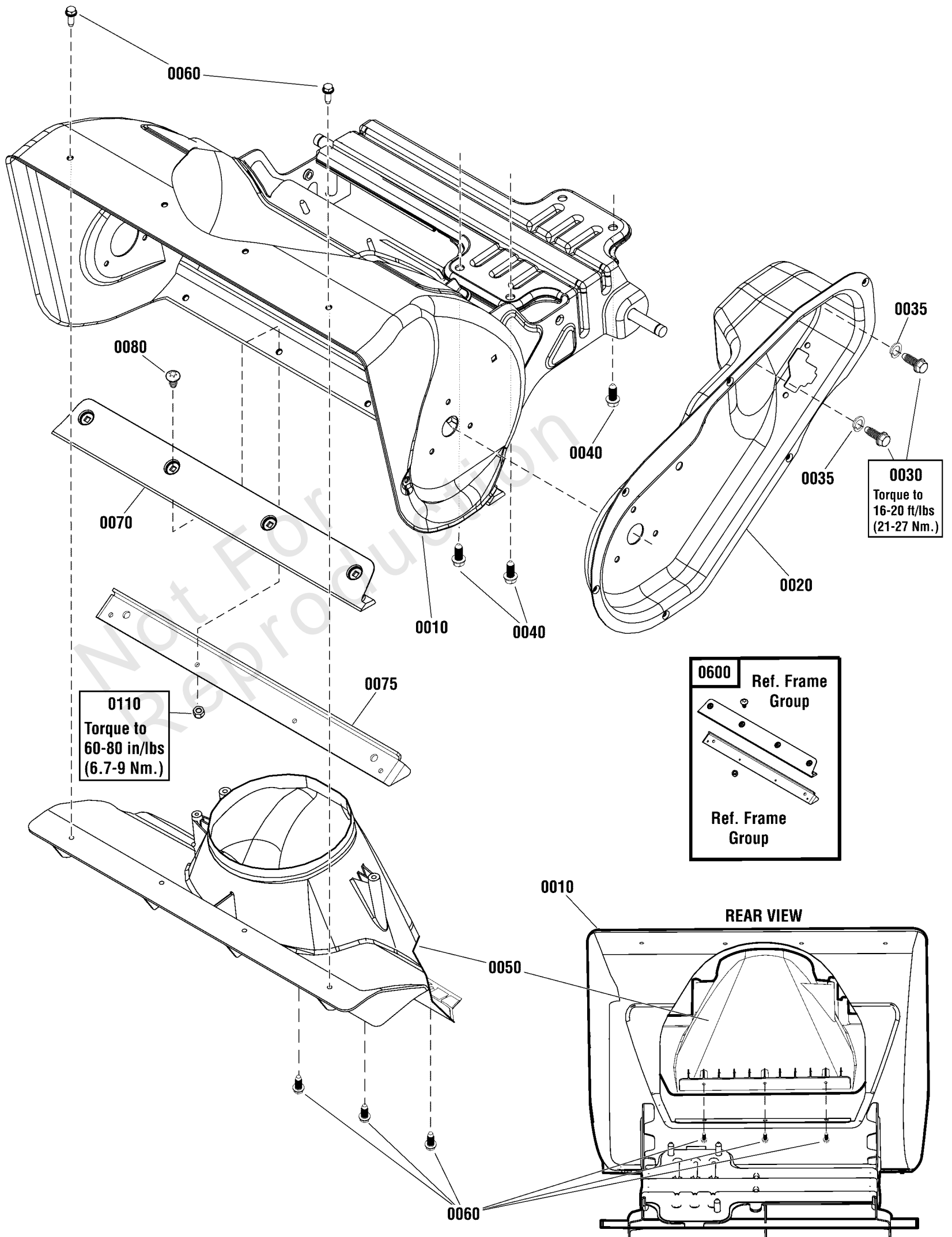

Frame Group

REF NO	PART NO	QTY	DESCRIPTION
0010	1756280AYP	1	FRAME ASSEMBLY
0020	1739100BMYP	1	HOUSING, Drive
0030	1752876YP	2	CAPSCREW, Hex Head, 5/16-24 x 5/8
0035	1917356SM	2	WASHER, Lock Helical Spring
0040	2828635SM	3	SCREW, Taptite, 3/8-16 X 1 1/4
0050	1739555YP	1	CHIMNEY -Used without Service Kit 1687864, Refer to Chute Rotation Group
0050	707849	1	CHIMNEY -Used with Service Kit 1687864, Refer to Chute Rotation Group
0060	1750444YP	5	SCREW, Hi-Low, 1/4-15 x 3/4
0070		1	SCRAPER BAR -(Included with Ref. No. 0600)
0075	1752660AYP	1	SUPPORT, Scraper Blade -(Included with Ref. No. 0600)
0080	5025299X5YP	4	SCREW, Allen Head, 1/4-20 x 5/8 -(Included with Ref. No. 0600)
0110	1752935YP	4	NUT, Hex Lock, Nylon, 1/4-20 -(Included with Ref. No. 0600)
0600	1687805	1	KIT, Scraper Bar -(Includes Ref. Nos. 0070, 0075, 0080, 0110, Auger Flights & Hardware)

Not For
Reproduction

Handles & Controls Group - Electric

Note: Unless noted otherwise, use the standard torque specifications

Mfg. No: 1696507-00

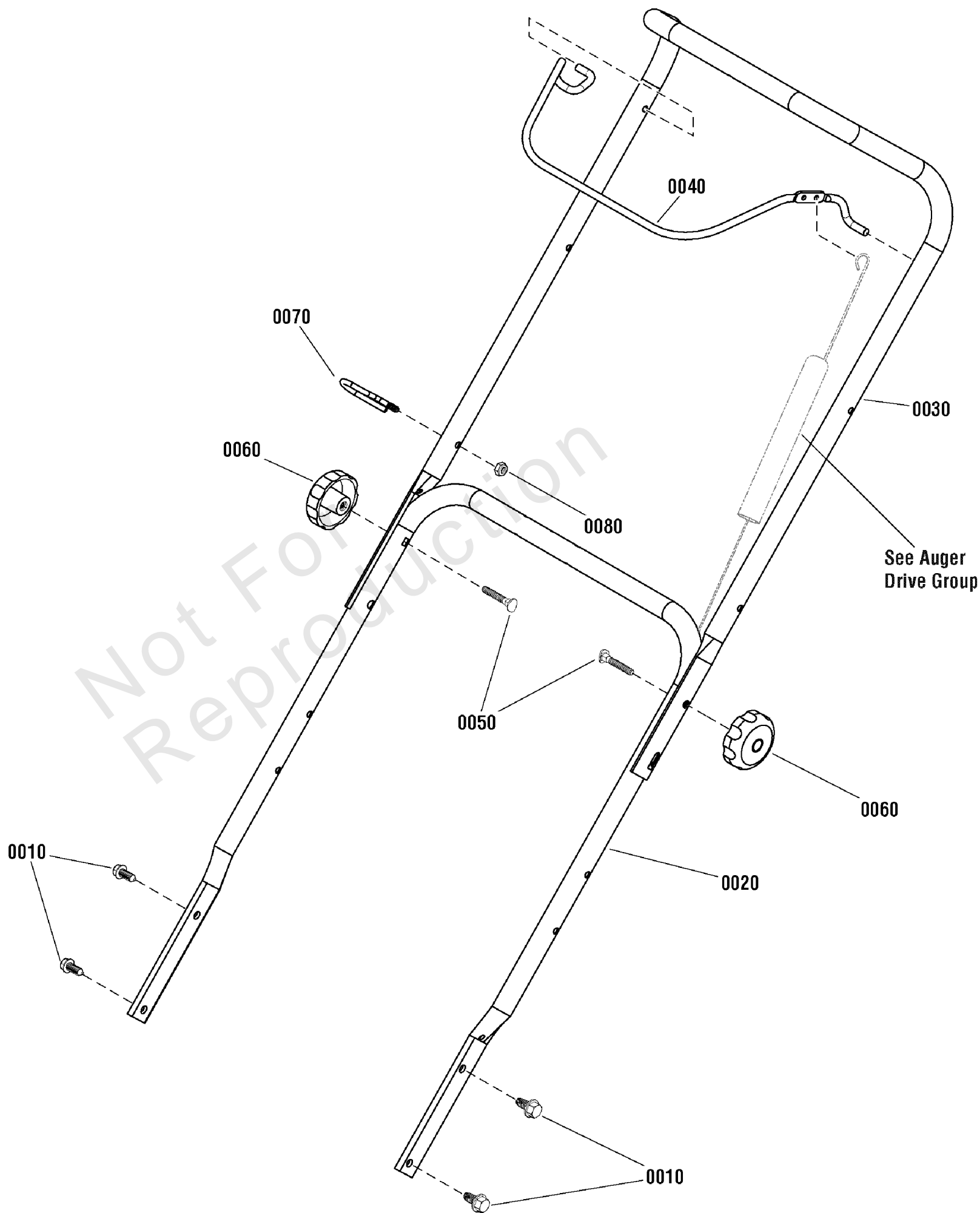

Handles & Controls Group - Electric

REF NO	PART NO	QTY	DESCRIPTION
0010	1930601SM	4	SCREW, Hex Washer Head, Taptite, 5/16-18 x 5/8
0020	1739362AYP	1	HANDLEBAR, Lower
0030	1739363AYP	1	HANDLEBAR, Upper
0040	1739361BNYP	1	BAIL, Engine Stop
0050	7091189YP	2	BOLT, Carriage, Curved Head, 5/16 x 2, G2
0060	1101453MA	2	KNOB, Handle, 5/16-18
0070	1739389YP	1	GUIDE, Rope
0080	7091603SM	1	NUT, 1/4

Not For
Reproduction

Light Panel Group

Note: Unless noted otherwise, use the standard torque specifications

Mfg. No: 1696507-00

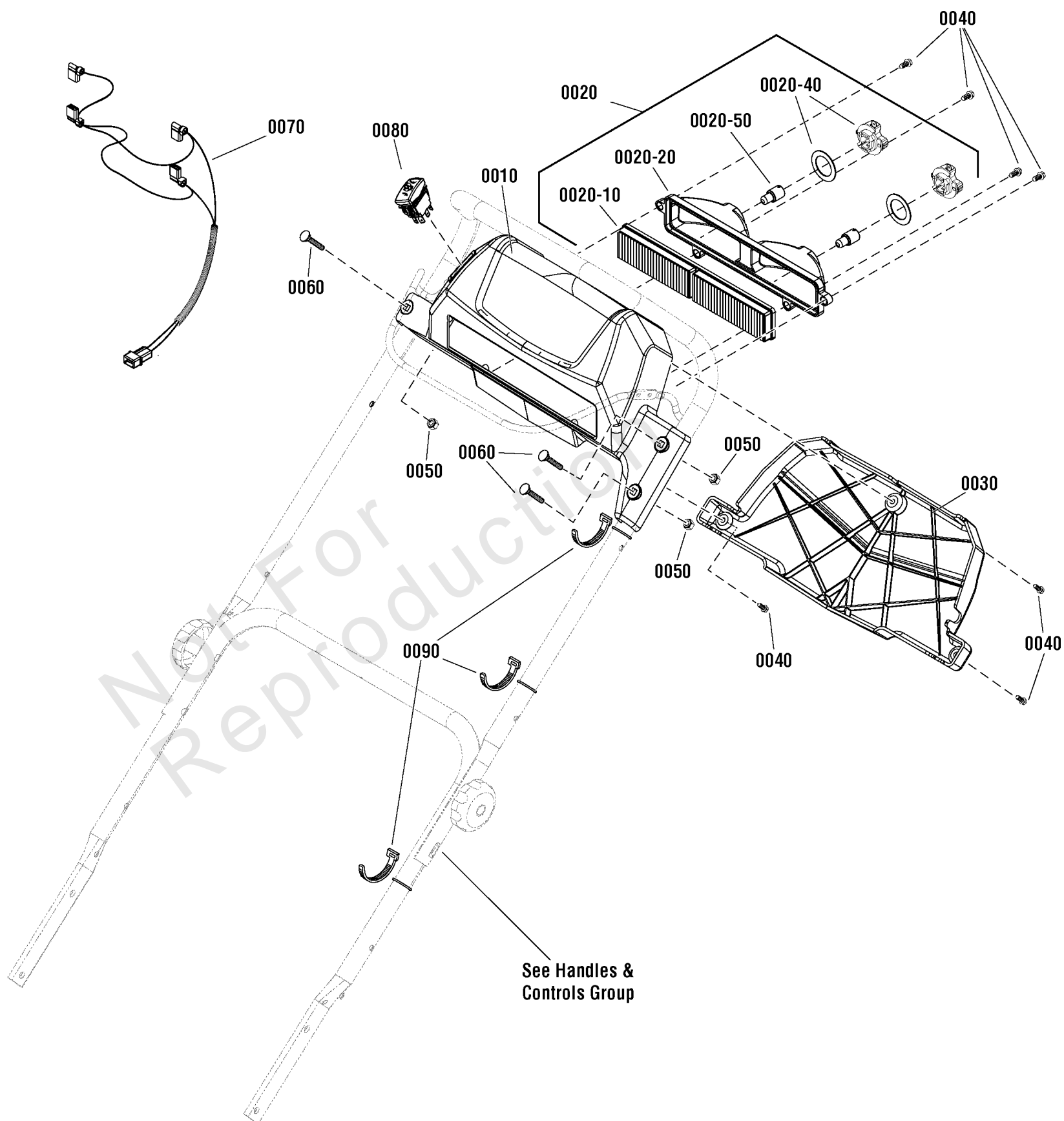

Light Panel Group

REF NO	PART NO	QTY	DESCRIPTION
0010	706787	1	PANEL -(-Used before Serial No. 2017125703)
0010	708157	1	PANEL -(-Used after Serial No. 2017125704)
0020	1736176YP	1	HEADLIGHT ASSEMBLY -(Includes Ref. Nos. 0020-10, 0020-20, 0020-40 & 0020-50)
0020-10	1736177YP	1	LENS, Twin Light
0020-20	1736178YP	1	DEFLECTOR
0020-40	1736180YP	2	SOCKET & GASKET ASSEMBLY, Headlight
0020-50	1736181YP	2	BULB, HEADLIGHT 12V 15W (1156)
0030	706481	1	COVER, Light Panel
0040	7091105YP	7	SCREW, Hex Washer Head, #10-16 x 1/2
0050	703232	3	NUT, Nylock, 1/4
0060	706482	3	BOLT,GR5, 1/4-20 X 1.5
0070	706483	1	WIRING HARNESS -(-Used before Serial No. 2017125703)
0070	708158	1	WIRING HARNESS -(-Used after Serial No. 2017125704)
0080	1754865YP	1	SWITCH, Chute Rotation
0090	7024649YP	4	WIRE TIE, 11 Inch Std Black Nylon

Not For
Reproduction

Wheel & Body Covering Group

Note: Unless noted otherwise, use the standard torque specifications

Mfg. No: 1696507-00

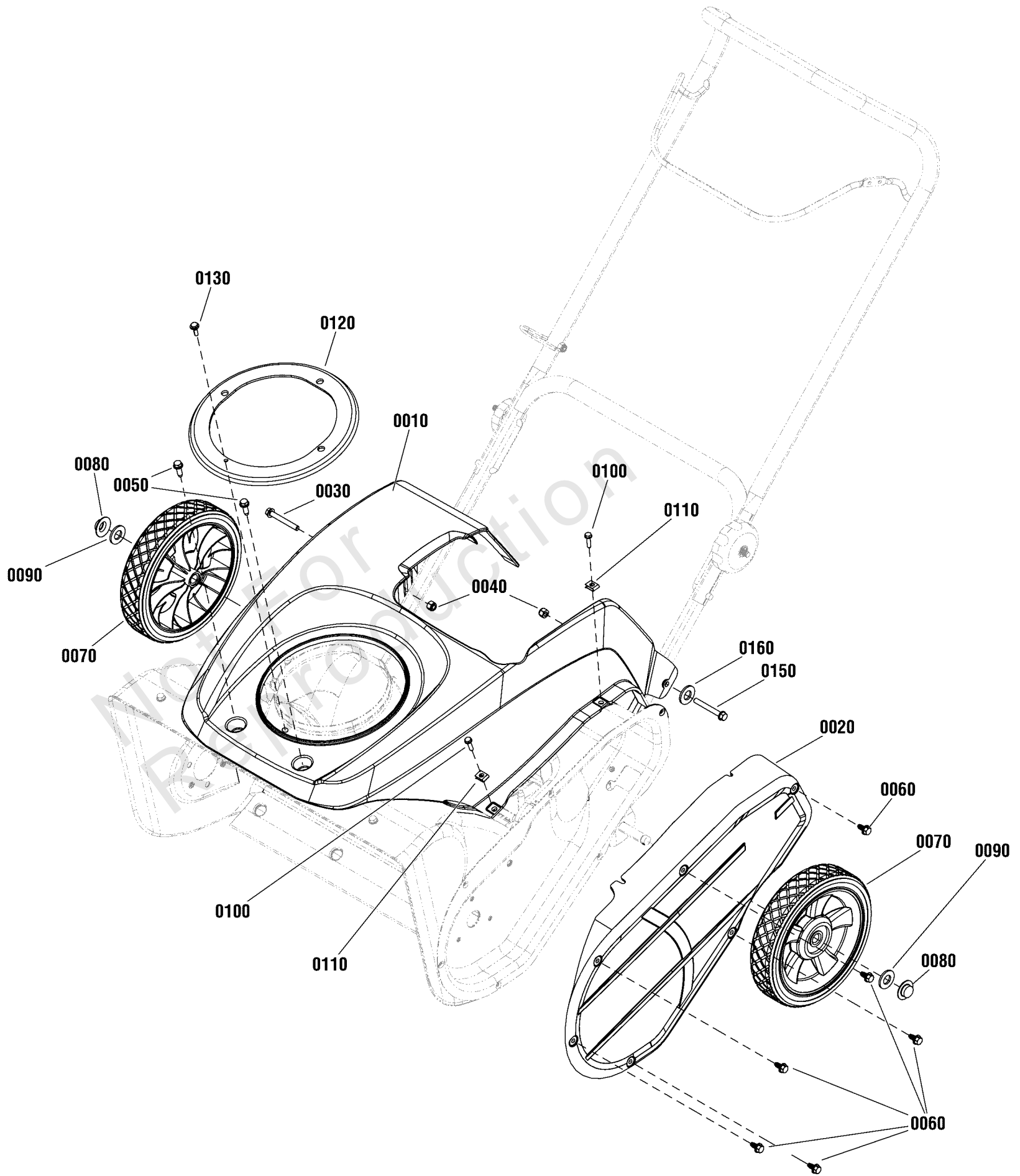

Wheel & Body Covering Group

REF NO	PART NO	QTY	DESCRIPTION
0010	1754520YP	1	COVER, Top
0020	1739599YP	1	COVER, Drive Case, Black
0030	1750777YP	1	CAPSCREW, Hex Washer Head, 1/4 x 20 x 2
0040	703232	2	NUT, Nylock, 1/4
0050	1750444YP	2	SCREW, Hi-Low, 1/4-15 x 3/4
0060	1750447YP	6	SCREW, Hex Washer Head, Trilob, 1/4-20 x 1/2
0070	311237YP	2	WHEEL, 2 x 8, Plastic 1/2
0080	703179	2	PUSHNUT, 1/2
0090	7025074SM	2	WASHER, Flat, 17/32 x 5/8
0100	1750638YP	2	CAPSCREW, Hex Washer Head, 10-24 x 3/4
0110	885118YP	2	NUT, U-Style Speed, #10
0120	1739752YP	1	COVER, Chute Moisture
0130	316042MA	1	SCREW, Hex Washer Head, #10-HL x 5/8
0150	703588	1	CAPSCREW, Hex Head, 1/4-20 x 1-3/4
0160	703332	1	WASHER, Flat, 1/4

Not For
Reproduction

Hardware Identification & Torque Specifications

Torque Specification Chart								
FOR STANDARD METRIC MACHINE HARDWARE (Tolerance ± 20%)								
Property Class	5.6		8.8		10.9		12.9	
	Class 5.6		Class 8.8		Class 10.9		Class 12.9	
Size Of Hardware	in/lbs	Nm.	in/lbs	Nm.	in/lbs	Nm.	in/lbs	Nm.
	ft/lbs		ft/lbs		ft/lbs		ft/lbs	
M3	5.88	.56	13.44	1.28	19.2	1.80	22.92	2.15
M4	13.44	1.28	30.72	2.90	43.44	4.10	52.56	4.95
M5	26.4	2.50	60.96	5.75	5.97	8.10	7.15	9.7
M6	44.64	4.3	7.3	9.9	10.3	14	12.1	16.5
M7	5.2	7.1	12.1	16.5	16.9	23	19.9	27
M8	7.7	10.5	17.7	24	25	34	29	40
M10	15	21	35	48	50	67	59	81
M12	26	36	61	83	86.2	117	103	140
M14	42	58	101	132	136	185	162	220
M16	64	88	147	200	210	285	250	340
M18	89	121	202	275	287	390	346	470
M20	126	171	290	390	405	550	486	660
M22	169	230	390	530	559	745	656	890
M24	217	295	497	375	708	960	840	1140
M27	320	435	733	995	1032	1400	1239	1680
M30	435	590	995	1350	1401	1900	1681	2280
M33	590	800	1349	1830	1902	2580	2278	3090
M36	759	1030	1740	2360	2441	3310	2935	3980
M39	988	1340	2249	3050	3163	4290	3798	5150

Torque Specification Chart						
FOR STANDARD MACHINE HARDWARE (Tolerance ± 20%)						
Hardware Grade	No Marks		SAE Grade 5		SAE Grade 8	
	SAE Grade 2		SAE Grade 5		SAE Grade 8	
Size Of Hardware	in/lbs	Nm.	in/lbs	Nm.	in/lbs	Nm.
	ft/lbs		ft/lbs		ft/lbs	
8-32	19	2.1	30	3.4	41	4.6
8-36	20	2.3	31	3.5	43	4.9
10-24	27	3.1	43	4.9	60	6.8
10-32	31	3.5	49	5.5	68	7.7
1/4-20	66	7.6	8	10.9	12	16.3
1/4-28	76	8.6	10	13.6	14	19.0
5/16-18	11	15.0	17	23.1	25	34.0
5/16-24	12	16.3	19	25.8	29	34.0
3/8-16	20	27.2	30	40.8	45	61.2
3/8-24	23	31.3	35	47.6	50	68.0
7/16-14	30	40.8	50	68.0	70	95.2
7/16-20	35	47.6	55	74.8	80	108.8
1/2-13	50	68.0	75	102.0	110	149.6
1/2-20	55	74.8	90	122.4	120	163.2
9/16-12	65	88.4	110	149.6	150	204.0
9/16-18	75	102.0	120	163.2	170	231.2
5/8-11	90	122.4	150	204.0	220	299.2
5/8-18	100	136	180	244.8	240	326.4
3/4-10	160	217.6	260	353.6	386	525.0
3/4-16	180	244.8	300	408.0	420	571.2
7/8-9	140	190.4	400	544.0	600	816.0
7/8-14	155	210.8	440	598.4	660	897.6
1-8	220	299.2	580	788.8	900	1,244.0
1-12	240	326.4	640	870.4	1,000	1,360.0

The guides and ruler furnished below are designed to help you select the appropriate hardware.



Nut, M8

Thread Diameter (mm)

Inside Diameter (in) Threads per inch

Nut, 1/2-16

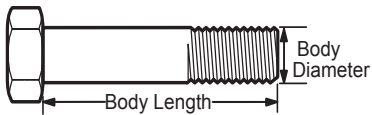

Screw, M8- 1.25 x 25

Thread Diameter (mm) Distance between threads (mm) Body Length (mm)

Body Diameter Threads per inch Body Length (in)

Screw, 1/2- 16 x 2



Standard Hardware Sizing

When a washer or nut is identified as 1/2" (M8), this is the *Nominal size*, meaning the *inside diameter* is 1/2 inch (8mm metric thread diameter); if a second number is present it represents the *threads per inch* (distance between threads).

When bolt or capscrew is identified as 1/2 - 16 x 2" (M8 - 1.25 x 50), this means the *Nominal size*, or body diameter is 1/2 inch (8mm metric thread diameter), the second number, 16, represents the *threads per inch*, (*distance between threads*). The final number is the body length of the bolt or screw, 2 inches (50mm).

NOTES

- These torque values are to be used for all hardware excluding: locknuts, self-tapping screws, thread forming screws, sheet metal screws and socket head setscrews.
- Recommended seating torque values for locknuts:
 - for prevailing torque locknuts - use 65% of grade 5 torques.
 - for flange whizlock nuts and screws - use 135% of grade 5 torques.
- Unless otherwise noted on assembly drawings, all torque values must meet this specification.

Common Hardware Types

Hex Head Capscrew



Washer



Carriage Bolt



Hex Nut

Wrench & Fastener Size Guide

1/4" Bolt or Nut Wrench—7/16"	5/16" Bolt or Nut Wrench—1/2"	3/8" Bolt or Nut Wrench—9/16"	7/16" Bolt or Nut Wrench (Bolt)—5/8" Wrench (Nut)—11/16"	1/2" Bolt or Nut Wrench—3/4"
M6 Bolt or Nut Wrench—10mm	M8 Bolt or Nut Wrench—13mm	M10 Bolt or Nut Wrench—17mm	M12 Bolt or Nut Wrench—19mm	M14 Bolt or Nut Wrench—22mm

