



Parts Manual

Mfg. No: 1696238-00
H1730E, 16.5GT 30" Dual Stage
Snowthrower

日本国内モデル専用部品

1, スターター動作用コード

品名：エクステンションコード ND-5M

品番：4905568061554

2, スターター動作用コード変換アダプタ

品名：グラウンドアダプタ：HS-AE15

品番：04-7268

3, 交換用ヘッドライトハロゲンバルブ

品名：ハロゲンバルブ

品番：HAL881

Model Components	Page
Auger Drive Group.....	4
Auger Housing Group.....	6
Chute & Rotation Group - Full Electric.....	8
Decals Group.....	10
Engine & Frame Group - 11.5, 14.5 & 16.5 Gross TP.....	12
Gear Case Assembly - 1754690YP (1754690).....	16
Handles & Controls Group.....	18
Traction Drive Group - General Transmission.....	22
Transmission SERVICE PARTS - General Transmission H2 (1733972).....	24
Wheels & Tires Group.....	26
Torque Specification Chart.....	28

Not For
Reproduction

Auger Drive Group

Note: Unless noted otherwise, use the standard torque specifications

Mfg. No: 1696238-00

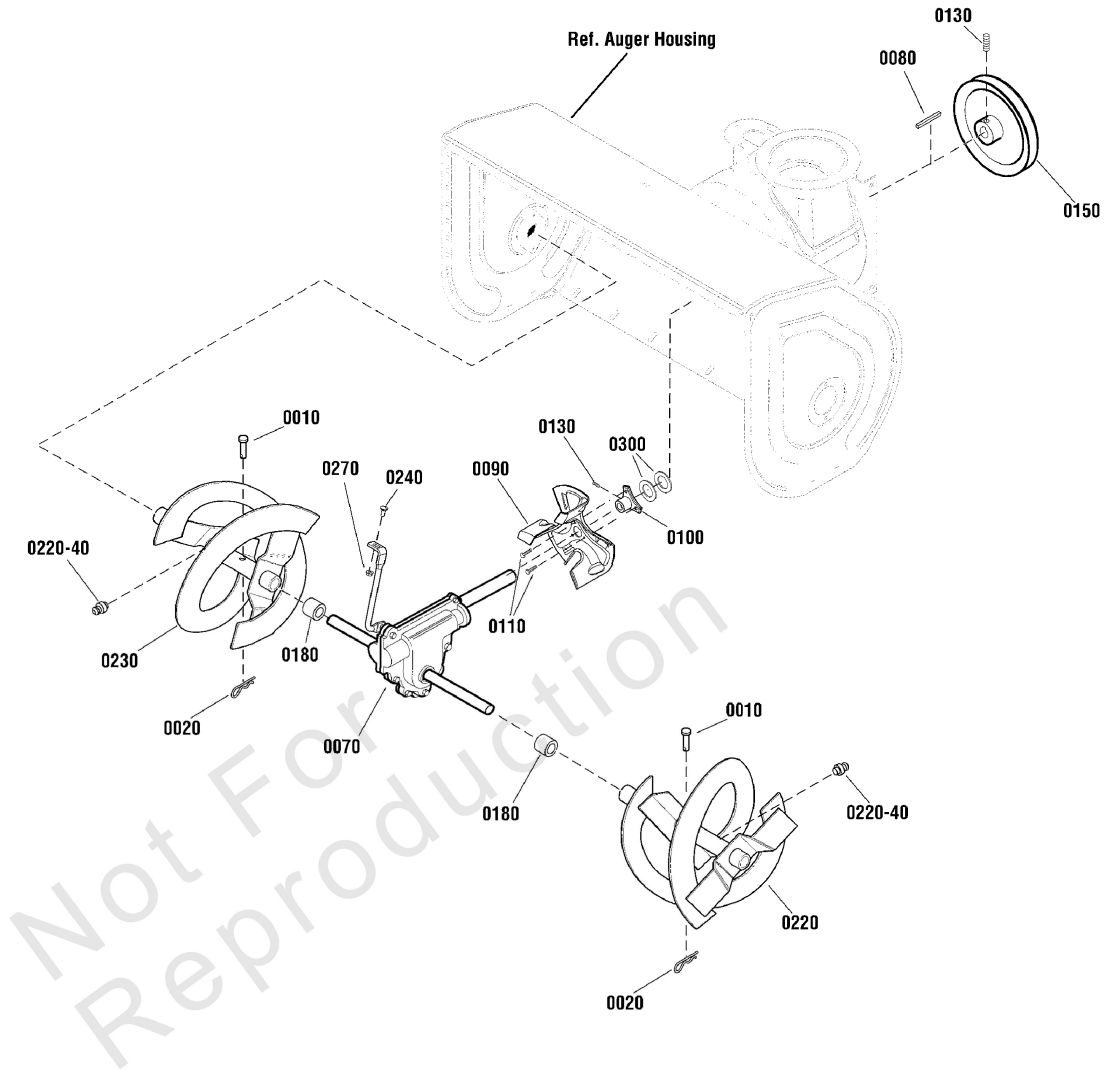

Auger Drive Group

REF NO	PART NO	QTY	DESCRIPTION
0010	703063	2	PIN, SHEAR
0020	703060	2	PIN, BOW TIE, 3/16
0070	1754690YP	1	GEAR CASE ASSEMBLY -(Use on models before S/N: 2016925903)
0070	1755811YP	1	GEAR CASE ASSEMBLY -(Use on models with S/N: 2016925903 and after.)
0080	2001022MA	1	KEY,SQUARE 3/16 X 3/4
0090	1739094AYP	1	IMPELLER
0100	1739073YP	1	HUB, Impeller
0110	1924856SM	3	SCREW, Hex Washer Head, Taptite, 5/16-18 x 1/2
0130	7090848SM	3	SET SCREW, Square Head, 5/16-18 x 1/2
0130	1930540SM	3	SET SCREW, Square Head, 5/16-18 x 5/8 -(Use on 26" Models)
0150	1752220YP	1	PULLEY, AUGER
0180	1733406SM	2	SPACER, Auger -(Use on 26" Models)
0220	1737079BMYP	1	AUGER ASSEMBLY, 28, LH -(Use on 28" & 30" Models)
0220	1737083BMYP	1	AUGER ASSEMBLY, 24, LH -(Use on 26" Models)
0230	1737078BMYP	1	AUGER ASSEMBLY, 28, RH -(Use on 28" & 30" Models)
0230	1737082BMYP	1	AUGER ASSEMBLY, 24, RH -(Use on 26" Models)
0220-40	2821133SM	1	FITTING, Zerk
0240	703185	1	RHSSNB
0270	015X79MA	1	NUT, Flange, 5/16-18, G5
0300	703151	2	WSHR

Auger Housing Group

Note: Unless noted otherwise, use the standard torque specifications

Mfg. No: 1696238-00

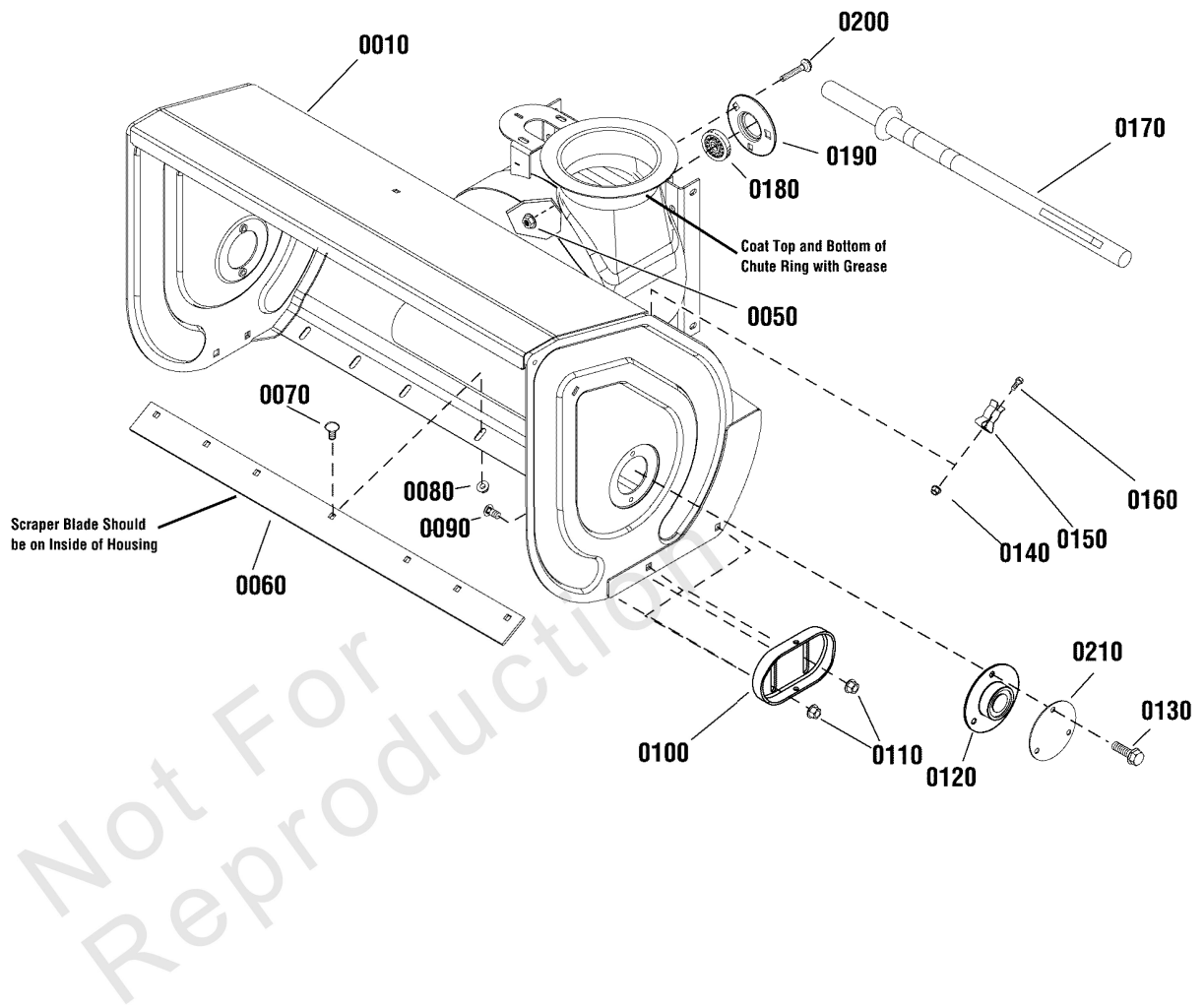

Auger Housing Group

REF NO	PART NO	QTY	DESCRIPTION
0010	1687705YP	1	KIT, AUGER HSNG, 26
0010	1687704YP	1	AUGER HOUSING, 28"
0010	1687605YP	1	AUGER HOUSING, 30"
0050	703115	3	NUT
0060	1732384BMYP	1	BLADE, SCRAPER 26"
0060	1709947BMYP	1	BLADE, SCRAPER 28
0060	1732385BMYP	1	SCRAPER BAR, 30"
0070	703159	5	BOLT -(Qty 7 Used 30" Models)
0080	1935048SM	5	NUT, Hex Flange, 5/16-18 -(Qty 7 Used 30" Models)
0090	703130	4	BOLT
0100	1750222YP	2	SKID SHOE
0110	703158	4	NUT, Hex Flange, ESNA, 3/8-16
0120	1733103SM	2	BEARING, Flange
0130	703167	6	SCREW
0140	15X146MA	2	NUT, Nylock, #10-24
0150	1736620YP	2	CLAMP, Retainer
0160	1960569SM	2	SCREW, Truss Head Torx, #10-24 x 3/8
0170	1736094YP	1	STICK-CLEANOUT W/BRUSH
0180	2108202SM	1	BEARING, BALL
0190	1665982SM	1	BEARING RETAINER - PL
0200	703185	3	RHSSNB
0210	1734932BMYP	2	COVER, Bushing

Chute & Rotation Group - Full Electric

Note: Unless noted otherwise, use the standard torque specifications

Mfg. No: 1696238-00

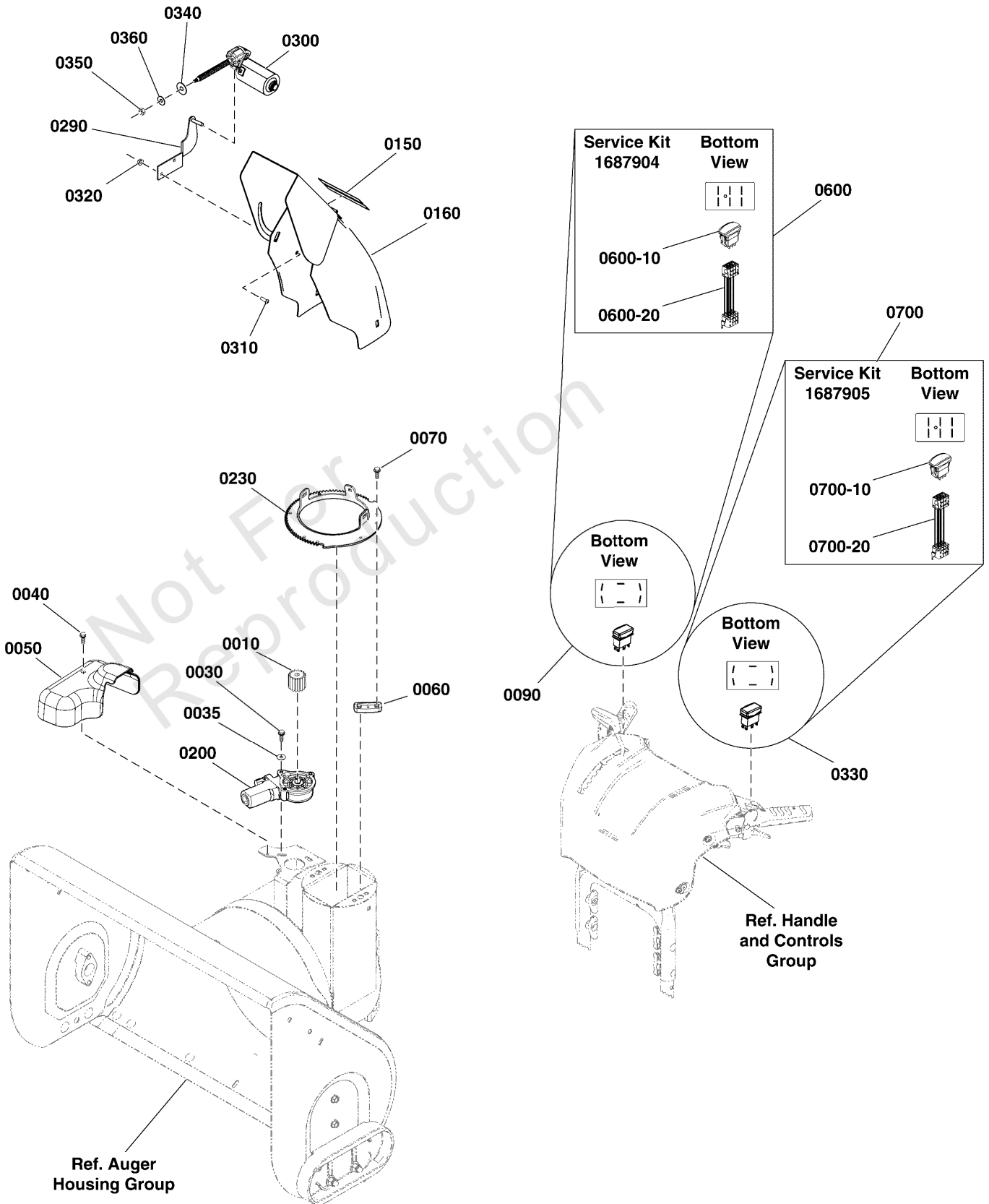

Chute & Rotation Group - Full Electric

REF NO	PART NO	QTY	DESCRIPTION
0010	1728967SM	1	PINION, 1-1/4 Lg
0030	1739621YP	3	SCREW, Torx Button Head, M5 x .8 x 14
0035	7091552SM	3	WASHER, Flat, 7/32 x 1/2
0040	1925592SM	1	CAPSCREW, Hex Washer, Taptite, 1/4-20 x 3/4
0050	1752877YP	1	COVER, Electric Chute Rotation
0060	7011938SM	3	RETAINER, Spout
0070	1960001SM	6	CAPSCREW, Hex Washer, 10-14 x 5/8
0090	1754865YP	1	SWITCH, Chute Rotation -(-Used Before Serial No. 2017430819) (Order 0600 When Bottom View of Switch Terminal Pattern Matches 0090.)
0150	1706085SM	2	DECAL, Hinge
0160	1752841C	1	WELD CHUTE C6 STL ELEC ROT ELEC DF ORNG
0200	1739309YP	1	MOTOR, Spout Rotator, 38"
0230	1737962BMYP	1	GEAR, Tall, Steel Chute
0290	1738267BMYP	1	BRACKET ASSEMBLY
0300	1737941YP	1	MOTOR, Chute Deflector
0310	1960715SM	2	SCREW, Truss Head, Torx, 1/4-20 X 3/4
0320	1960694SM	2	NUT, Hex Flange, 1/4-20
0330	1737379YP	1	SWITCH, Deflector Control -(-Used Before Serial No. 2017430819) (Order 0700 When Bottom View of Switch Terminal Pattern Matches 0330.)
0340	1738244YP	1	WASHER, Rubber
0350	1738245YP	1	NUT, 1/4-20, L.H.
0360	703332	1	WASHER
0600	1687904	1	WIRE HARNESS ADAPTER KIT, CHUTE ROTATION -(-Used Before Serial No. 2017430819) (Order 0600-10 When Bottom View of Switch Terminal Pattern Matches 0600.)
0600-10	709954	1	SWITCH, Chute Rotation -(-Used After Serial No. 2017430818)
0600-20	84003010	1	HARNESS, Wire -(-Used Before Serial No. 2017430819)
0700	1687905	1	WIRE HARNESS ADAPTER KIT, DEFLECTOR CONT -(-Used Before Serial No. 2017430819) (Order 0700-10 When Bottom View of Switch Terminal Pattern Matches 0700.)
0700-10	709955	1	SWITCH, Deflector Control -(-Used After Serial No. 2017430818)
0700-20	84003010	1	HARNESS, Wire -(-Used Before Serial No. 2017430819)

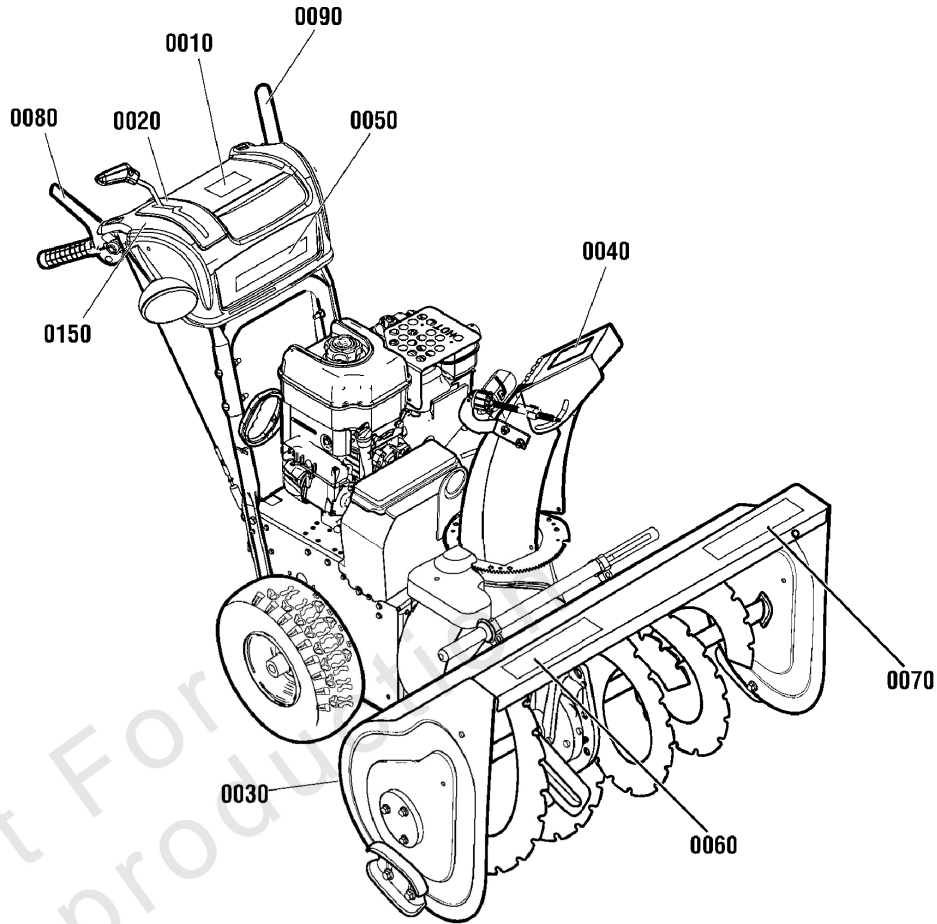

⚠ DANGER

Amputation Hazard
 • Contact with auger will cause serious injury.
 • Keep hands, feet and clothing away.
 • Keep bystanders away.

Thrown Objects Hazard
 • Never direct discharge chute towards persons or property.

Read the operator's manual for operating and safety instructions.

Shut off engine and remove key before performing maintenance or repair work.

Risque d'amputation
 • Tout contact avec la tarière provoquera de graves blessures.
 • Tenez vos pieds, vos mains et vêtements à distance.
 • Tenez les spectateurs à distance.

Danger objets projetés
 • Ne jamais diriger la chute en direction des personnes ou biens matériels.

Lisez les instructions de sécurité et d'utilisation dans le manuel d'utilisation.

Arrêtez le moteur et retirez la clé avant d'effectuer tout entretien ou toute réparation.

1696238-00

0030



0030



0080



0090

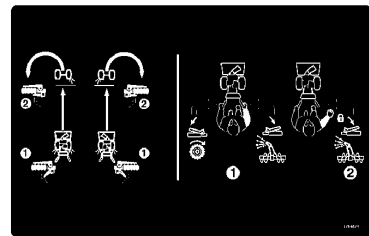

0010



0020

⚠ DANGER

Amputation hazard
 Contact with moving parts inside chute will cause serious injury.
 • Shut off engine before unclogging discharge chute.
 • Use clean-out tool, not hands!

Risque d'amputation
 Tout contact avec des pièces en mouvement à l'intérieur de la goulotte provoquera de graves blessures.
 • Arrêtez le moteur avant de débarrasser la goulotte d'obstruction.
 • Utilisez l'outil de débarrassage, pas les mains!

1727207

0040



0040

MODEL #

0060



0050

Do not shift with the engine stopped.

Ne pas changer de vitesse avec le moteur à l'arrêt.

1755584

0150

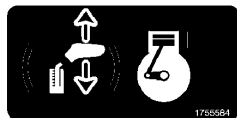

0150



0070

Decals Group

REF NO	PART NO	QTY	DESCRIPTION
0010	1754679YP	1	DECAL, Dash Operation
0020	1751582YP	1	DECAL, GEAR SHIFT
0030	1737866YP	1	DECAL, Foot, FR/Eng -(Domestic)
0030	1737867YP	1	DECAL, Danger Auger Icons -(Export)
0040	1737865YP	1	DECAL, Chute Warning, FR/ENG -(Domestic)
0040	1727207SM	1	DECAL, Chute Warning -(Export)
0050	1754671YP	1	DECAL, Dash, Logo
0060	1754852YP	1	DECAL, Model H1226E
0060	1754853YP	1	DECAL, Model H1528E
0060	1754675YP	1	DECAL, Model SIH1528SE
0060	1754854YP	1	DECAL, Model H1730E
0060	1754676YP	1	DECAL, Model SIH1730SE
0070	1733247SM	1	DECAL, Logo, Housing, 25" -(Use on 26" & 28" Models)
0070	1733246SM	1	DECAL, Logo, Housing, 27" -(Use on 30")
0080	1753133YP	1	DECAL, Auger Control Symbols
0090	1753134YP	1	DECAL, Traction Control Symbols
0150	1755585YP	1	DECAL, Do Not Shift -(Domestic)
0150	1755584YP	1	DECAL, Do Not Shift, No Text -(Export)

Engine & Frame Group - 11.5, 14.5 & 16.5 Gross TP

Note: Unless noted otherwise, use the standard torque specifications

Mfg. No: 1696238-00

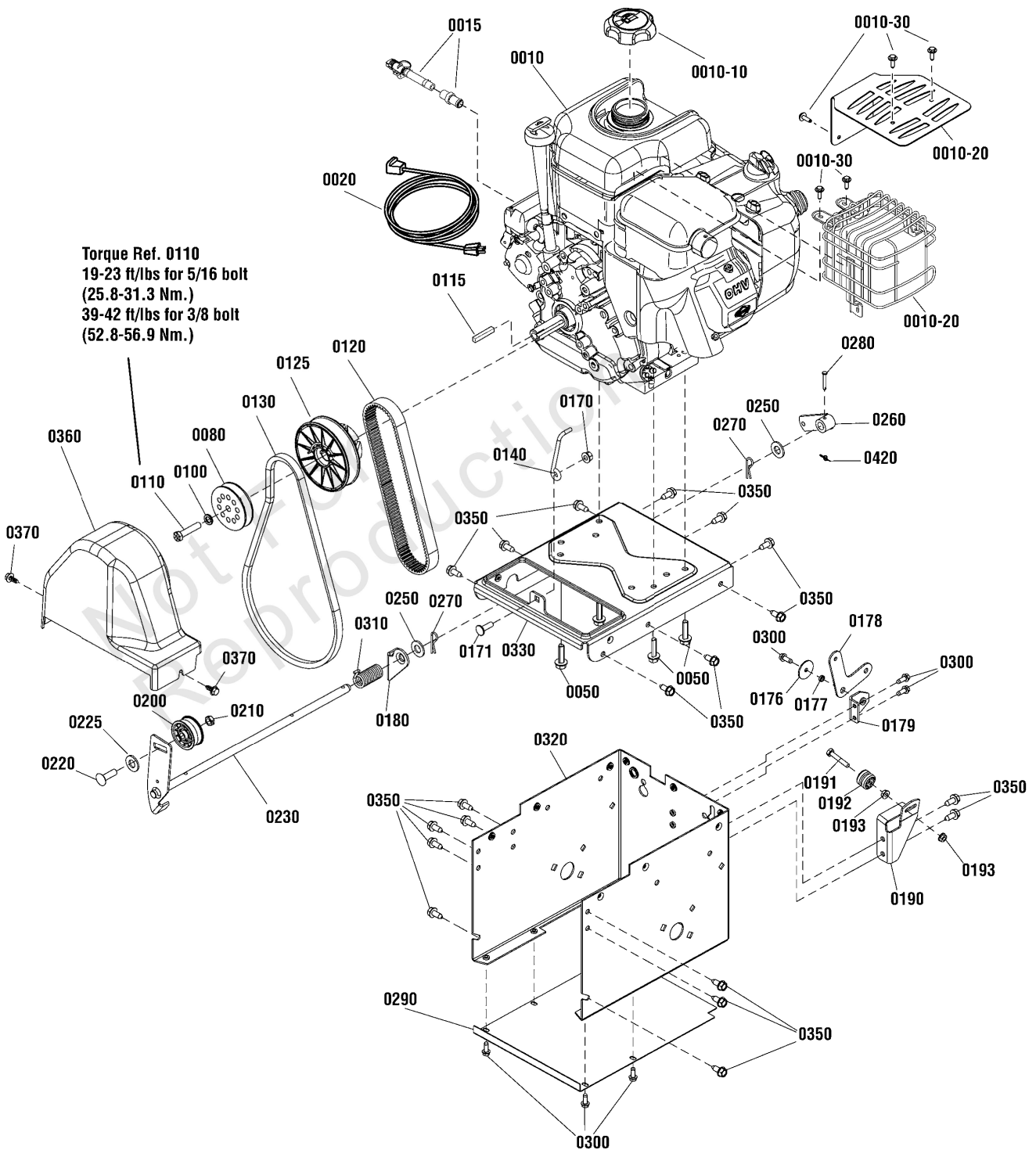

Engine & Frame Group - 11.5, 14.5 & 16.5 Gross TP

REF NO	PART NO	QTY	DESCRIPTION
0010	15C114-0153-F8	1	* ENGINE, 11.5 Gross TP Briggs & Stratton, Domestic -(Engine Model: 15C114-0153-F8)
0010	15C107-0035-F8	1	* ENGINE, 11.5 Gross TP Briggs & Stratton, Domestic -(Engine Model: 15C107-0035-F8)
0010	20M314-0135-F1	1	* ENGINE, 14.5 Gross TP Briggs & Stratton, Domestic -(Engine Model: 20M314-0135-F1)
0010	20M314-0142-H1	1	* ENGINE, 14.5 Gross TP Briggs & Stratton, Export -(Engine Model: 20M314-0142-H1)
0010	21M314-0129-H1	1	* ENGINE, 16.5 Gross TP Briggs & Stratton, Export -(Engine Model: 21M314-0129-H1)
0010	21M314-0127-F1	1	* ENGINE, 16.5 Gross TP Briggs & Stratton, Domestic -(Engine Model: 21M314-0127-F1)
0010-10	792647	1	* CAP, Fuel -(Use on Domestic Models)
0010-10	795027	1	CAP, Fuel Tank -(Use on CE/Export Models)
0010-20	797003	1	* GUARD, Muffler, Plate -(Use on 11.5 Gross TP only)
0010-20	797095	1	* GUARD, Muffler, Plate -(Use on 14.5TP & 16.5TP Domestic Models)
0010-20	796384	1	GUARD, Muffler -(Use on 14.5TP & 16.5TP CE/Export Models)
0010-30	699854	2	* SCREW, Muffler Guard -(Use on 11.5 Gross TP only)
0010-30	699854	3	* SCREW, Muffler Guard
0015	798980	1	* HOSE, Oil Drain
0020	6219MA	1	CORD, Electric, 10FT. 110V -(Use on Domestic Models Only)
0050	75246GS	4	TAPTITE
0080	1737509YP	1	PULLEY
0100	1916965SM	1	LOCKWASHER, Spring, 3/8 -(Use on 14.5 & 16.5 Gross TP only)
0100	703116	1	LCKWSHR -(Use on 11.5 Gross TP only)
0110	703132	1	CAPSCREW, Hex Head, 3/8-24 x 1-3/4, G8 -(Use on 14.5 & 16.5 Gross TP only)
0110	1750393YP	1	CAPSCREW, Hex Head, 5/16-24 x 1-3/4 -(Use on 11.5 Gross TP only)
0115	2157427SM	1	KEY, Parallel, 3/16 x 3/16 x 1-1/4
0120	1737220YP	1	V-BELT, Multi-Speed
0125	1733968YP	1	PULLEY
0130	1736421YP	1	V-BELT, 4L, 38.35, Auger
0140	1737377YP	1	STOP, Belt
0170	703222	1	NUT, Hex, KEPS, 5/16-18
0171	1931335SM	1	BOLT, Carriage, Short Neck, 5/16-18 x 1
0176	703136	1	WASHER
0177	703124	1	SPACER, 1/4 x .118, G5
0178	1737329YP	1	BELLCRANK
0179	1737328AYP	1	BRACKET, Lower
0180	1737297YP	1	BRACKET, Support, Auger Idler
0190	1737347BMYP	1	BRACKET, Guide Wheel
0191	703234	1	CAPSCREW, 1/4-20X1.5
0192	579860MA	1	SPOOL CABLE, Auger Control

Footnotes:

Note:* To verify your specific engine model, please reference the ID Tag located on your engine. See your local Briggs & Stratton distributor for parts and service.

Engine & Frame Group - 11.5, 14.5 & 16.5 Gross TP

Note: Unless noted otherwise, use the standard torque specifications

Mfg. No: 1696238-00

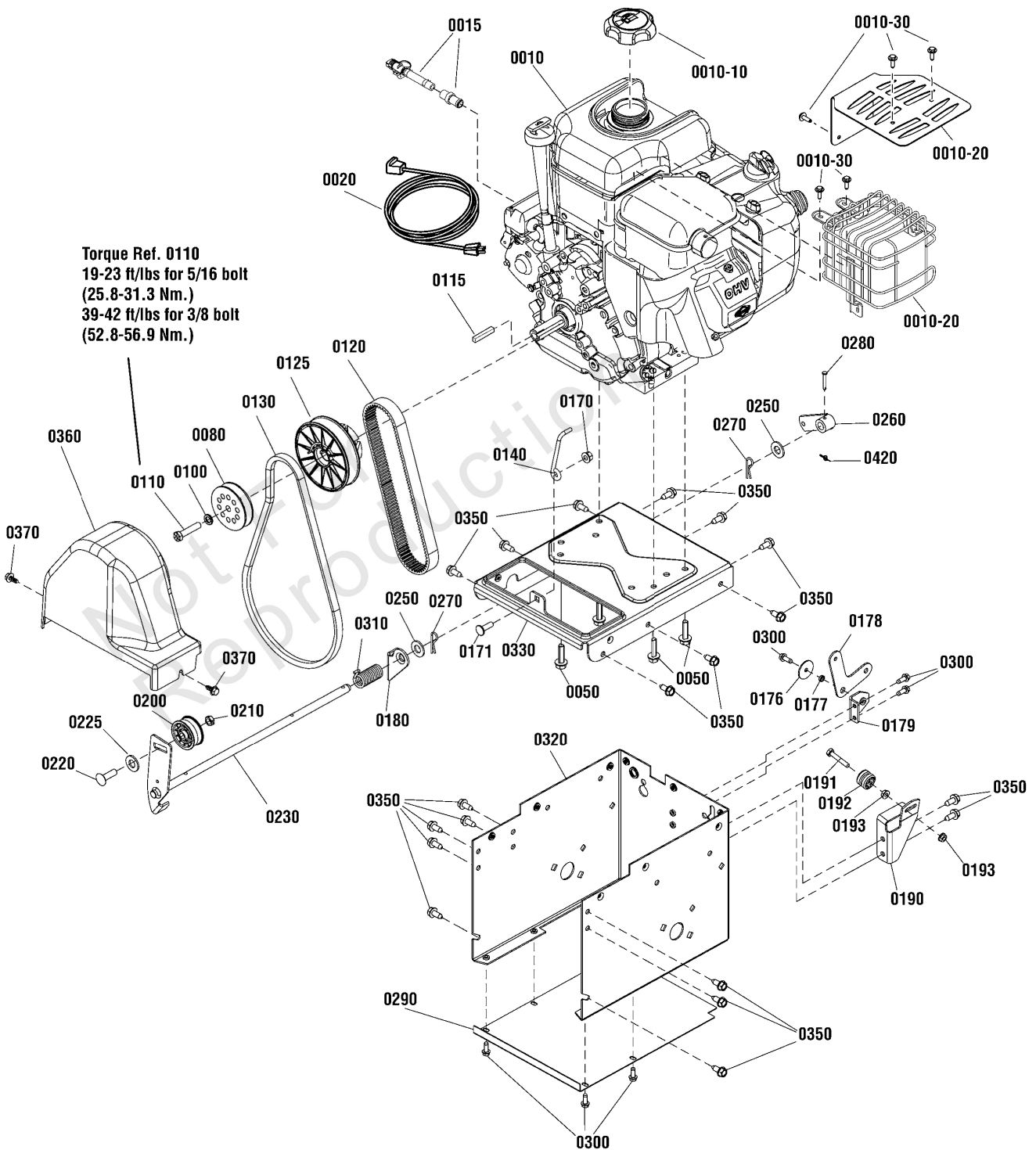

Engine & Frame Group - 11.5, 14.5 & 16.5 Gross TP

REF NO	PART NO	QTY	DESCRIPTION
0193	703233	2	NUT, 1/4-20, GR5
0200	1502120MA	1	IDLER, Plastic Ball Bearing
0210	703230	1	NUT, 3/18-16, GR2
0220	703227	1	BOLT, 3/8-16 X 1.25
0225	1670971SM	1	WASHER, Thrust, 1/2 ID x 1 OD
0230	1737296YP	1	AUGER IDLER
0250	1960027SM	3	WASHER, 1/2
0260	1733451SM	1	ARM, Control
0270	703300	2	PIN, 3/32 X 1.6
0280	703313	1	PIN, CLEVIS, ZINC
0290	1737221BMYP	1	PANEL, Bottom
0300	703054	9	SCREW, 1/4-20X0.625
0310	1737350YP	1	SPRING, Torsion
0320	1737106CYP	1	FRAME
0330	1754136CYP	1	PLATE, Engine -(Use on 14.5 & 16.5 Gross TP only)
0330	1754138CYP	1	PLATE, Engine -(Use on 11.5 Gross TP only)
0350	703228	19	SCREW, 5/16-18 X .75
0360	1750551YP	1	COVER, Belt
0370	1751355YP	2	SCREW, 1/4-20 X 3/4
0420	7023590SM	1	PIN, Cotter, Self Locking, 1/4

Footnotes:

Note:* To verify your specific engine model, please reference the ID Tag located on your engine. See your local Briggs & Stratton distributor for parts and service.

Gear Case Assembly - 1754690YP (1754690)

Note: Unless noted otherwise, use the standard torque specifications

Mfg. No: 1696238-00

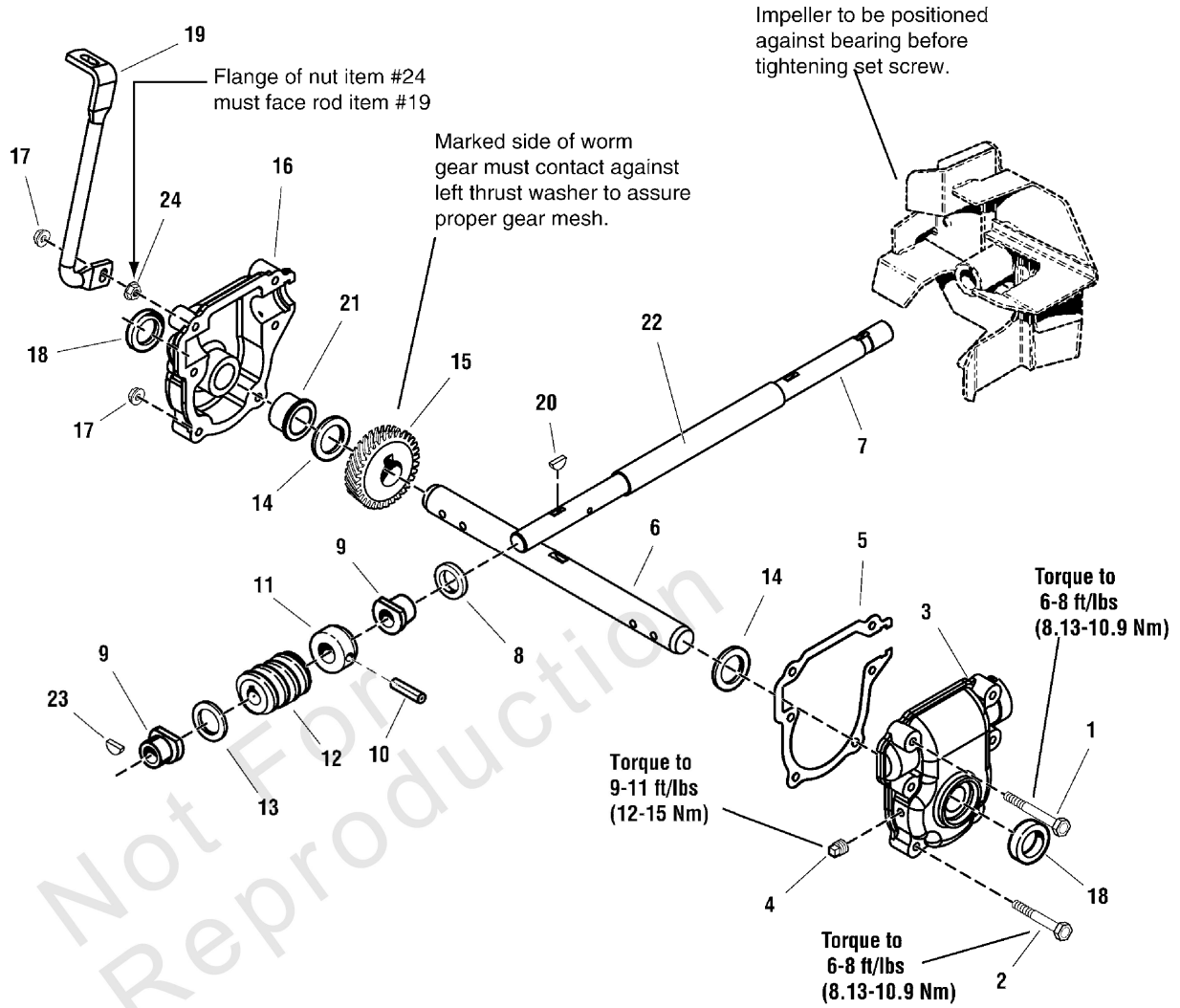

Gear Case Assembly - 1754690YP (1754690)

REF NO	PART NO	QTY	DESCRIPTION
1	1926105SM	1	CAPSCREW, 1/4-20 x 2-3/4
2	1960346SM	5	CAPSCREW-HEX
3	1734218SM	1	GEAR CASE, Left
4	1668971SM	1	TAPERED PIPE PLUG
5	1612124SM	1	GASKET
6	1732440SM	1	SHAFT, Auger Cutoff
7	1754687YP	1	SHAFT, Worm Cutoff
8	1612093SM	1	SEAL, Oil
9	1612149SM	2	FLANGE BUSHING
10	2836098SM	1	PIN, Drive Lock
11	1612127SM	1	THRUST COLLAR
12	1612142SM	1	GEAR-WORM
13	2168111SM	1	WASHER, Thrust
14	2118315SM	2	WASHER, Thrust
15	1612141SM	1	GEAR, Worm
16	1734219SM	1	GEAR CASE, Right
17	1930642SM	6	NUT, Top Lock Flange, 1/4-20
18	2118118SM	2	SEAL
19	1732152SM	1	BRACKET, Wireform
20	2818312SM	1	KEY, Woodruff
21	1732991SM	2	BUSHING
22	1612111SM	1	TUBE
23	2830246SM	1	KEY, Woodruff
24	1960294SM	1	NUT, Flange, 1/4-20

Handles & Controls Group

Note: Unless noted otherwise, use the standard torque specifications

Mfg. No: 1696238-00

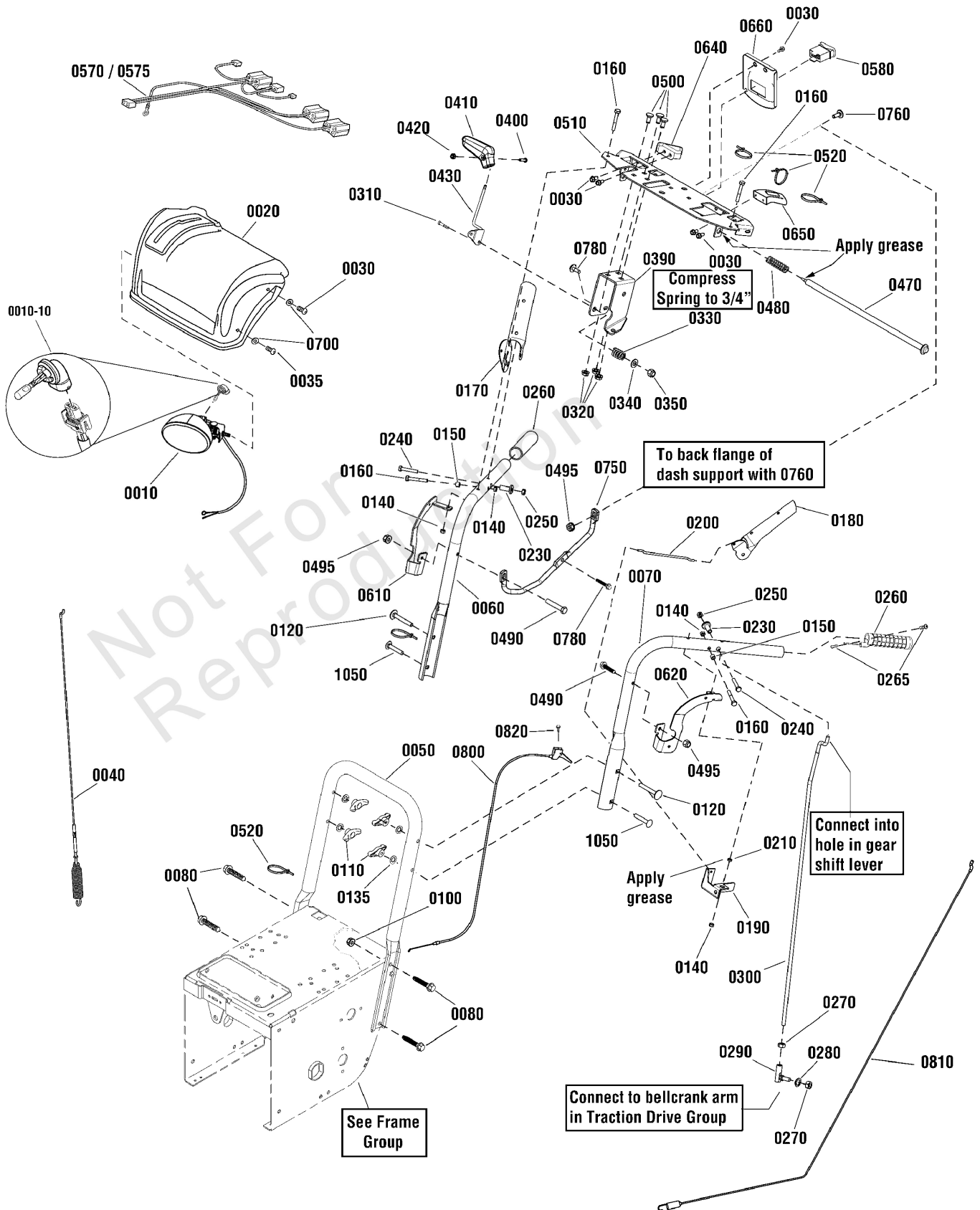

Handles & Controls Group

REF NO	PART NO	QTY	DESCRIPTION
0010	1737965YP	1	HEADLIGHT ASSEMBLY
0010-10	----	1	* BULB, Headlight, Halogen, 881-12V 27W -(Included with Ref. No. 0010)
0020	1750682CYP	1	COVER, Panel
0030	1960556SM	8	SCREW, Truss Head Torx, 1/4-20 x 3/4
0035	1960715SM	1	SCREW, Truss Head Torx, 1/4-20 x 3/4
0040	703221	1	CABLE & SPRING ASSEMB
0050	1737274AYP	1	HANDLE, Lower
0060	1737531AYP	1	HANDLE, Upper, Right
0070	1737532AYP	1	HANDLE, Upper, Left
0080	1737687YP	2	CAPSCREW, Hex Head, 5/16-18 x 3/4 G5
0100	1935048SM	2	NUT, Hex Flange, Two Way Lock, 5/16-18
0110	7035744YP	4	KNOB, Wing, 5/16-18
0120	1750299YP	2	BOLT, Carriage, 5/16-18 x 2-1/4 G5
0135	7090391SM	4	WASHER, Internal Tooth, 5/16
0140	1920397SM	5	NUT, Hex Lock, ESNA Light, 1/4-20
0150	1678392SM	2	SPACER, 1/4ID x 3/8OD
0160	1921962SM	4	CAPSCREW, Hex Head, 1/4-20 x 1-3/4 G5
0170	1739783AYP	1	LEVER, CLUTCH, R.H.
0180	1739782AYP	1	LEVER, CLUTCH, L.H.
0190	1733505BMYP	1	BRACKET, Pivot, Free Hand
0200	1736360YP	1	ROD, 5-5/8 Inch
0210	1733095SM	1	SPACER, 1/4ID x 3/8OD
0230	1736542YP	2	SPACER, Stepped
0240	1750554YP	2	BOLT, Shoulder, 1/4 x 1-1/4
0250	1933896SM	3	NUT, Hex Lock, Nylon Insert, 10-24
0260	1738124YP	2	GRIP, Heated -(Used on 28" & 30" Domestic Models Only)
0260	1726317SM	2	HAND GRIP
0265	703044	1	SCREW -(Used on 28" & 30" Domestic Models Only)
0270	2820263SM	2	NUT, Hex, 5/16-24
0280	703116	1	LCKWSHR
0290	1739290YP	1	BALL JOINT
0300	1737331YP	1	ROD, Speed Select
0310	1923701SM	1	CAPSCREW, Hex Head, 3/8-16 x 2 G5
0320	1931277SM	3	NUT, Hex Flange, Whiz Lock, 5/16-18
0330	50786MA	1	SPRING, .509 DIA X0.75
0340	1918266SM	1	WASHER, 3/8
0350	1919439SM	1	NUT, Hex Lock, Esna Light, 3/8-16
0390	1737684YP	1	BRACKET, Controls
0400	1960589SM	1	SCREW, Phillips, #10-24 x 3/4
0410	1733192SM	1	GRIP, Lever
0420	1933896SM	2	NUT, Hex Lock Nylon Insert, 10-24
0430	703047	1	LEVER, SPEED
0470	1736363YP	1	ROD & SPRING ASSEMBLY
0480	2108360SM	2	SPRING, Compression
0490	7091003YP	2	BOLT
0495	703463	4	NUT, GR5, 1/4-20

Footnotes:

Note:* See your local hardware store for replacement bulbs.

Handles & Controls Group

Note: Unless noted otherwise, use the standard torque specifications

Mfg. No: 1696238-00

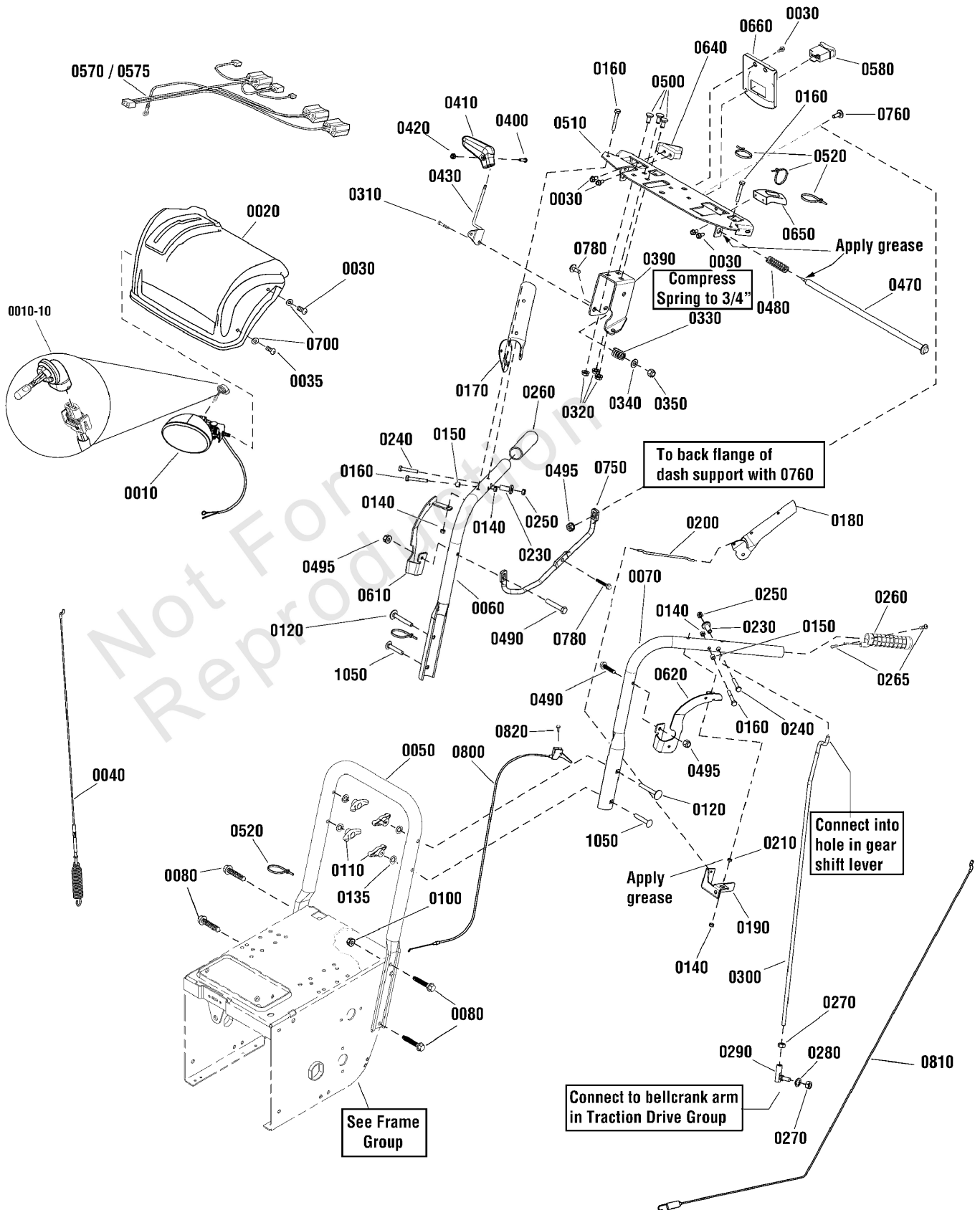

Handles & Controls Group

REF NO	PART NO	QTY	DESCRIPTION
0500	340720MA	3	BOLT, Carriage, 5/16-18 x 3/4
0510	1739500BMYP	1	COVER, Dash
0520	1701011SM	5	TIE, Self Lock
0570	1750773YP	1	WIRE HARNESS, Deflector -(-Used before Serial No. 2017250879)
0570	709957	1	WIRE HARNESS, Deflector -(-Used after Serial No. 2017250879)
0575	1752164YP	1	WIRE HARNESS, Heated Hand Grip -(Used on 28" & 30" Domestic Models Only)
0580	1752242YP	1	SWITCH, Heated Hand Grip -(Used on 28" & 30" Domestic Models Only)
0610	1750522BMYP	1	BRACKET, Mounting, RH
0620	1750521BMYP	1	BRACKET, Mounting, RH
0640	1739483AYP	1	POD, RH
0650	1739484AYP	1	POD, LH
0660	1739861BMYP	1	BRACKET, Heated Hand Grip -(Used on 28" & 30" Domestic Models Only)
0700	703332	2	WASHER
0750	1737552YP	1	BRACE
0760	703101	1	BOLT, 1/4-20X.75
0780	1925592SM	1	SCREW, Hex Washer Head, Taptite, 1/4-20 x 3/4
0800	1737510YP	2	CABLE, Steering Control
0810	1737511YP	1	CABLE, Traction Drive
0820	703134	2	BOLT, Oval Head, 10-24 x 1-1/2
1050	703059	2	BOLT, 5/16-18X2

Footnotes:

Note:* See your local hardware store for replacement bulbs.

Traction Drive Group - General Transmission

Note: Unless noted otherwise, use the standard torque specifications

Mfg. No: 1696238-00

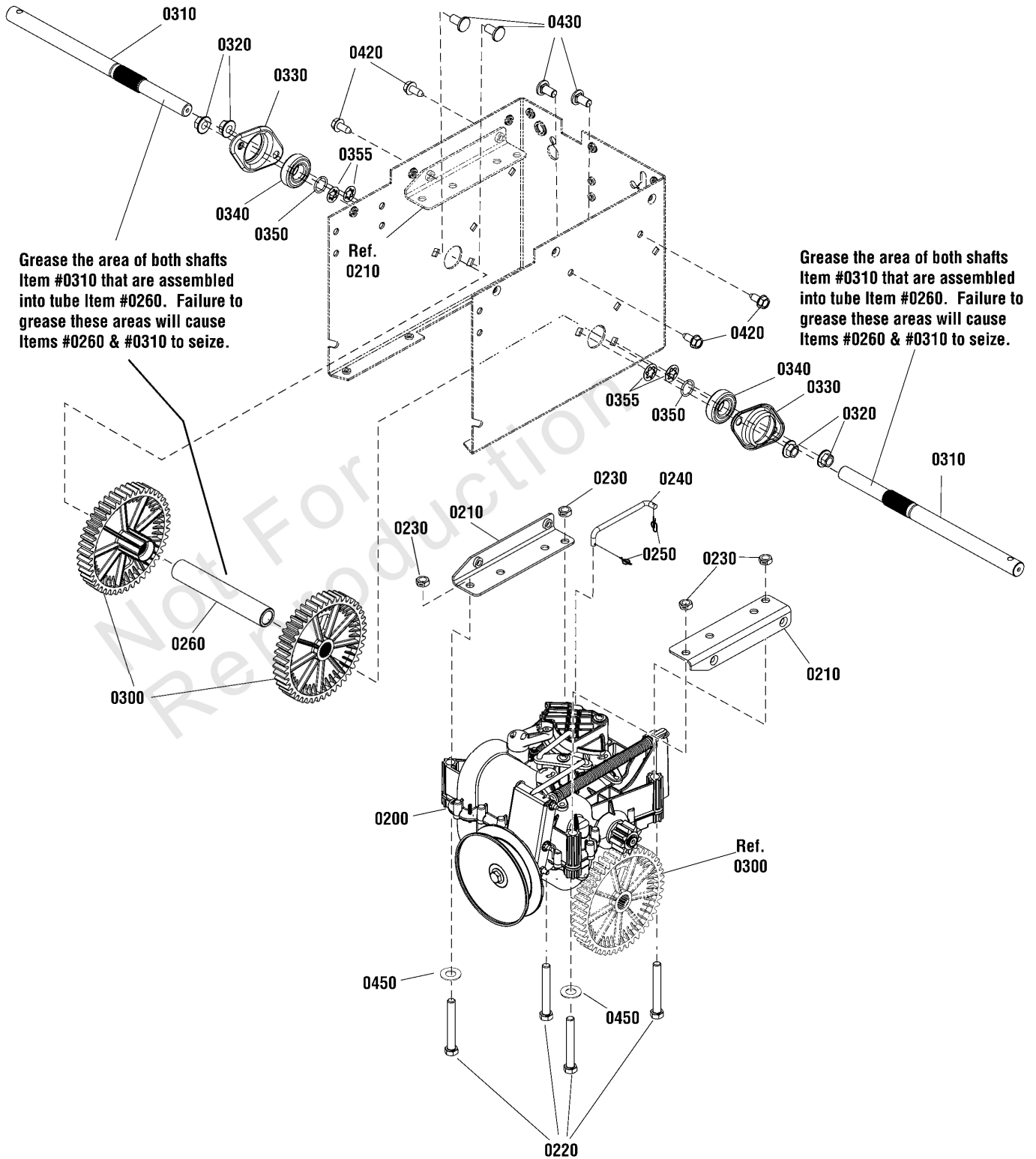

Traction Drive Group - General Transmission

REF NO	PART NO	QTY	DESCRIPTION
0200	1733972YP	1	TRANSMISSION, General Transmission H2
0210	1737267AYP	2	BRACKET
0220	7091557SM	4	(C) HHCS, 3/8C X2-3/4
0230	1960251SM	4	NUT, Hex Jam, 3/8-16
0240	1737330YP	1	ROD, Speed Select
0250	7023590SM	2	COTTER PIN, 1/4" Self Locking
0260	1737310YP	1	TUBE, Support
0300	1737311YP	2	GEAR, Drive
0310	1737309YP	2	AXLE
0320	1928352SM	4	NUT, Hex Flange, Whiz Lock Large, 3/8-16
0330	1736396YP	2	RETAINER, Bearing
0340	53263MA	2	BEARING, Ball
0350	1737742YP	2	RING, Retaining
0355	7013847YP	4	RETAINER, Bolt 3/8"
0420	1664847SM	4	SCREW, Hex Washer Head Taptite, 5/16-18 X 3/4
0430	1737686YP	4	BOLT, Carriage, FH GR 5, 3/8-16 x 3/4
0450	703184	2	WASHER, Flat, 3/8

Not For
Reproduction

Footnotes:

Note:* See Transmission Assembly Group for detailed service parts.

Transmission SERVICE PARTS - General Transmission H2 (1733972)

Note: Unless noted otherwise, use the standard torque specifications

Mfg. No: 1696238-00

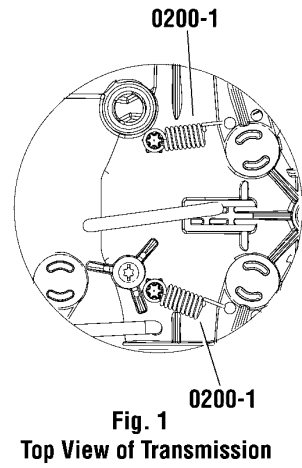
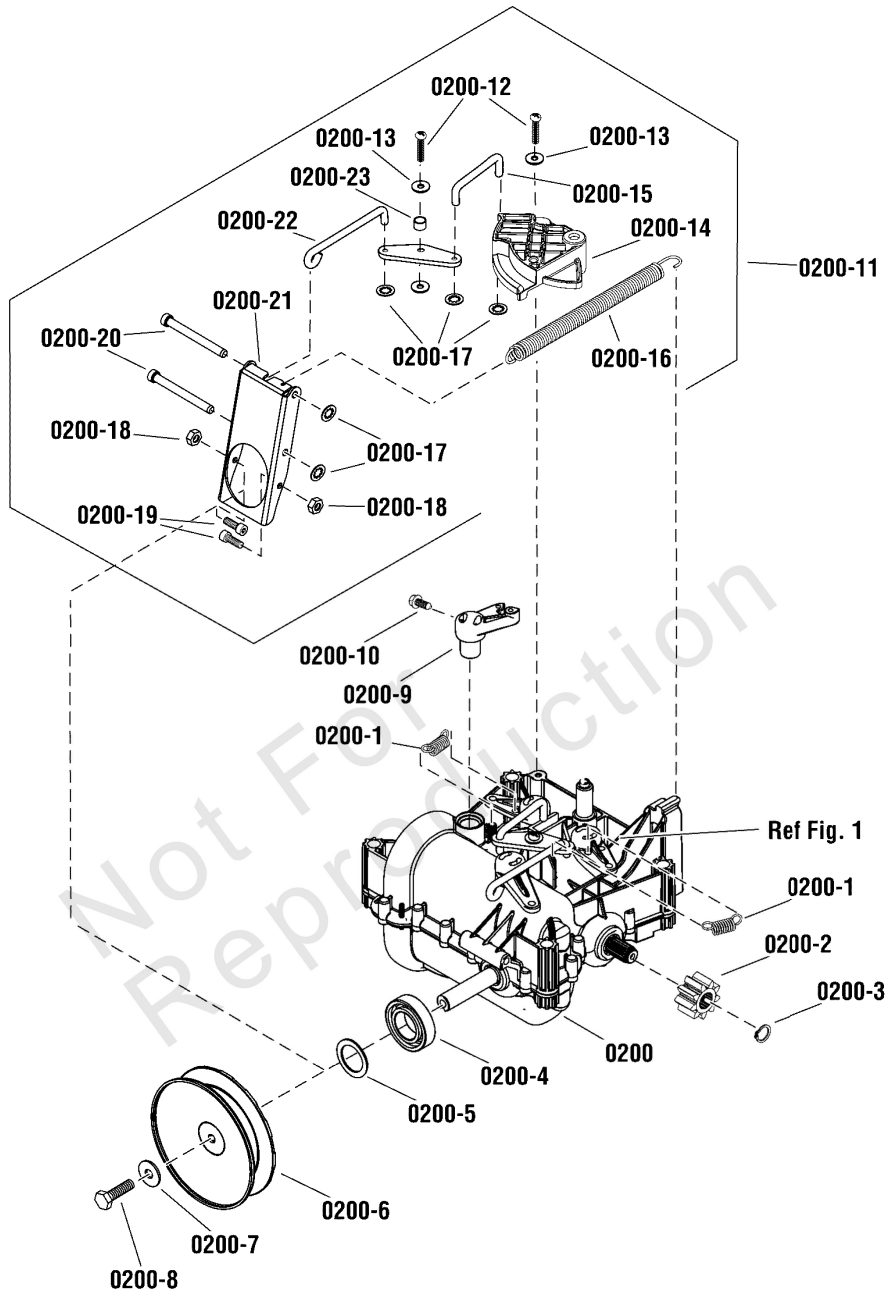

Transmission SERVICE PARTS - General Transmission H2 (1733972)

REF NO	PART NO	QTY	DESCRIPTION
0200	1733972YP	1	TRANSMISSION, Complete General Transmission H2
0200-1	1739646YP	2	SPRING, Traction, 8.75 Inches
0200-2	1739648YP	2	GEAR
0200-3	1739647YP	2	RETAINER
0200-4	1739639YP	1	BEARING, 6005 2RS
0200-5	1739636YP	1	WASHER, 25 X 35 X 1.5
0200-6	1739624YP	1	PULLEY ASSEMBLY
0200-7	1739623YP	1	WASHER, 0.8 X 27 X 3
0200-8	1739622YP	1	SCREW, M8x20 left
0200-9	1739642YP	1	LEVER
0200-10	1739643YP	4	SCREW, 4 X 16
0200-11	709902	1	KIT-TRANSMISSION CONTROL -(Includes Ref. Nos. 0200-12, 02200-13, 0200-14, 0200-15, 0200-16, 0200-17, 0200-18, 0200-19, 0200-20, 0200-21, 0200-22, 0200-23)
0200-12	1739645YP	1	SCREW, 5 X 25
0200-13	1739641YP	1	WASHER, 5.3 X 15 X 1.2
0200-14	1739644YP	1	CAM, Control
0200-15	----	1	ROD, Intermediate -(Order Ref. Nos. 0200-11)
0200-16	1739640YP	1	SPRING, Variator
0200-17	1739634YP	4	WASHER, Starlock
0200-18	1739626YP	2	NUT
0200-19	1739629YP	2	BOLT, Allen-Head, M5 X 1.2
0200-20	1739632YP	2	PIN, Axle
0200-21	1739625YP	1	SHIFT ARM
0200-22	----	1	ROD, Variation -(Order Ref. Nos. 0200-11)
0200-23	----	1	SPACER -(Order Ref. Nos. 0200-11)

Wheels & Tires Group

Note: Unless noted otherwise, use the standard torque specifications

Mfg. No: 1696238-00

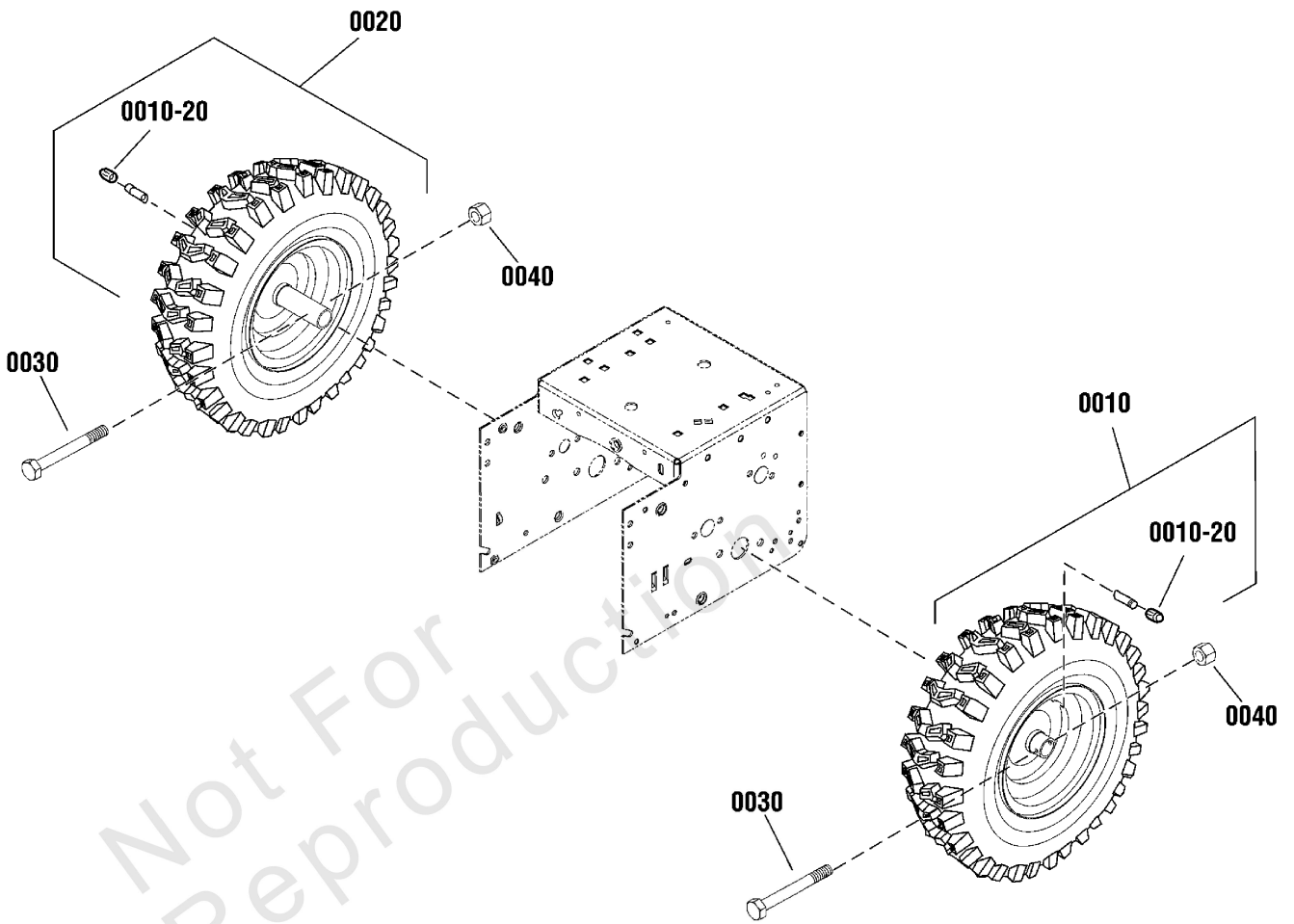

Wheels & Tires Group

REF NO	PART NO	QTY	DESCRIPTION
0010	1754243YP	1	WHEEL ASSEMBLY, 4.80-8, P2-578, LH -(Use on 26", 27" & 28" Models)
0010	1754484YP	1	WHEEL ASSMEBLY, 16 x 6.50, P2-578, LH -(Use on 30" Models)
0020	1754245YP	1	WHEEL ASSEMBLY, 4.80-8, P2-578, RH -(Use on 26", 27" & 28" Models)
0020	1754485YP	1	WHEEL ASSMEBLY, 16 x 6.50, P2-578, RH -(Use on 30" Models)
0010-20	2172353SM	2	VALVE STEM & CAP -(Included on 0010 & 0020)
0030	577015MA	2	SCREW, SHR 1/4-20X1.7
0040	703232	2	NUT, 1/4-20, NYLOCK

Not For Reproduction

Hardware Identification & Torque Specifications

Torque Specification Chart								
FOR STANDARD METRIC MACHINE HARDWARE (Tolerance ± 20%)								
Property Class	5.6		8.8		10.9		12.9	
	Class 5.6		Class 8.8		Class 10.9		Class 12.9	
Size Of Hardware	in/lbs		in/lbs		in/lbs		in/lbs	
	ft/lbs	Nm.	ft/lbs	Nm.	ft/lbs	Nm.	ft/lbs	Nm.
M3	5.88	.56	13.44	1.28	19.2	1.80	22.92	2.15
M4	13.44	1.28	30.72	2.90	43.44	4.10	52.56	4.95
M5	26.4	2.50	60.96	5.75	5.97	8.10	7.15	9.7
M6	44.64	4.3	7.3	9.9	10.3	14	12.1	16.5
M7	5.2	7.1	12.1	16.5	16.9	23	19.9	27
M8	7.7	10.5	17.7	24	25	34	29	40
M10	15	21	35	48	50	67	59	81
M12	26	36	61	83	86.2	117	103	140
M14	42	58	101	132	136	185	162	220
M16	64	88	147	200	210	285	250	340
M18	89	121	202	275	287	390	346	470
M20	126	171	290	390	405	550	486	660
M22	169	230	390	530	559	745	656	890
M24	217	295	497	375	708	960	840	1140
M27	320	435	733	995	1032	1400	1239	1680
M30	435	590	995	1350	1401	1900	1681	2280
M33	590	800	1349	1830	1902	2580	2278	3090
M36	759	1030	1740	2360	2441	3310	2935	3980
M39	988	1340	2249	3050	3163	4290	3798	5150

Torque Specification Chart						
FOR STANDARD MACHINE HARDWARE (Tolerance ± 20%)						
Hardware Grade	No Marks		SAE Grade 5		SAE Grade 8	
	SAE Grade 2		SAE Grade 5		SAE Grade 8	
Size Of Hardware	in/lbs		in/lbs		in/lbs	
	ft/lbs	Nm.	ft/lbs	Nm.	ft/lbs	Nm.
8-32	19	2.1	30	3.4	41	4.6
8-36	20	2.3	31	3.5	43	4.9
10-24	27	3.1	43	4.9	60	6.8
10-32	31	3.5	49	5.5	68	7.7
1/4-20	66	7.6	8	10.9	12	16.3
1/4-28	76	8.6	10	13.6	14	19.0
5/16-18	11	15.0	17	23.1	25	34.0
5/16-24	12	16.3	19	25.8	29	34.0
3/8-16	20	27.2	30	40.8	45	61.2
3/8-24	23	31.3	35	47.6	50	68.0
7/16-14	30	40.8	50	68.0	70	95.2
7/16-20	35	47.6	55	74.8	80	108.8
1/2-13	50	68.0	75	102.0	110	149.6
1/2-20	55	74.8	90	122.4	120	163.2
9/16-12	65	88.4	110	149.6	150	204.0
9/16-18	75	102.0	120	163.2	170	231.2
5/8-11	90	122.4	150	204.0	220	299.2
5/8-18	100	136	180	244.8	240	326.4
3/4-10	160	217.6	260	353.6	386	525.0
3/4-16	180	244.8	300	408.0	420	571.2
7/8-9	140	190.4	400	544.0	600	816.0
7/8-14	155	210.8	440	598.4	660	897.6
1-8	220	299.2	580	788.8	900	1,244.0
1-12	240	326.4	640	870.4	1,000	1,360.0

The guides and ruler furnished below are designed to help you select the appropriate hardware.

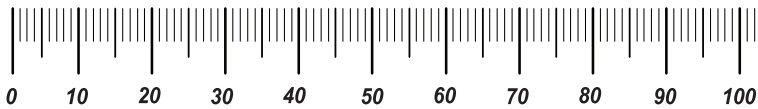

Nut, M8

Thread Diameter (mm)
Inside Diameter (in)
Threads per inch

Nut, 1/2-16

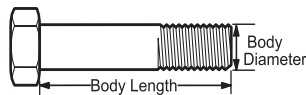

Screw, M8- 1.25 x 25

Thread Diameter (mm)
Body Diameter
Distance between threads (mm)
Threads per inch
Body Length (mm)
Body Length (in)

Screw, 1/2- 16 x 2



Standard Hardware Sizing

When a washer or nut is identified as 1/2" (M8), this is the *Nominal size*, meaning the *inside diameter* is 1/2 inch (8mm metric thread diameter); if a second number is present it represents the *threads per inch* (distance between threads).

When bolt or capscrew is identified as 1/2 - 16 x 2" (M8 - 1.25 x 50), this means the *Nominal size*, or body diameter is 1/2 inch (8mm metric thread diameter), the second number, 16, represents the *threads per inch*, (*distance between threads*). The final number is the body length of the bolt or screw, 2 inches (50mm).

NOTES

- These torque values are to be used for all hardware excluding: locknuts, self-tapping screws, thread forming screws, sheet metal screws and socket head setscrews.
- Recommended seating torque values for locknuts:
 - for prevailing torque locknuts - use 65% of grade 5 torques.
 - for flange whizlock nuts and screws - use 135% of grade 5 torques.
- Unless otherwise noted on assembly drawings, all torque values must meet this specification.

Common Hardware Types

Hex Head Capscrew

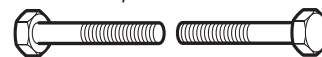

Washer



Lockwasher



Carriage Bolt

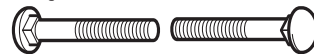

Hex Nut



Wrench & Fastener Size Guide

1/4" Bolt or Nut Wrench—7/16"	5/16" Bolt or Nut Wrench—1/2"	3/8" Bolt or Nut Wrench—9/16"	7/16" Bolt or Nut Wrench (Bolt)—5/8" Wrench (Nut)—11/16"	1/2" Bolt or Nut Wrench—3/4"
M6 Bolt or Nut Wrench—10mm	M8 Bolt or Nut Wrench—13mm	M10 Bolt or Nut Wrench—17mm	M12 Bolt or Nut Wrench—19mm	M14 Bolt or Nut Wrench—22 mm

